

**PROCEEDING OF THE TECHNICAL SEMINAR
ON
SOUTH CHINA SEA FISHERIES RESOURCES
Bangkok, THAILAND
21-25 May 1973**

organized by

SOUTHEAST ASIAN FISHERIES DEVELOPMENT CENTER

published by

JAPAN INTERNATIONAL COOPERATION AGENCY

Tokyo, JAPAN

March 1977

PREFACE

The present proceedings contains the record of discussions at the last SEAFDEC Seminar held at Bangkok in May 1973.

The Seminar, conducted with the participation of many experienced fisheries experts from SEAFDEC countries and other Southeast Asian countries, was made a great success by the active exchange of constructive expert opinions and views which offered a promising prospect for the future fisheries development in the whole Southeast Asian waters. The high evaluations given to the Seminar were manifested in the enthusiastic desire evinced by all countries and organizations concerned for early publication of its outcome which, however, has been postponed regrettably to date by reason of various restraints.

It therefore gives me a great pleasure to present herewith the proceedings of the Seminar compiled and published by Japan International Cooperation Agency in compliance with the request of the Secretariat of SEAFDEC.

Availing myself of this opportunity, I wish to express my deep gratitude to all organizations and individuals for the valuable assistance in the compilation of the proceedings, with my ardent hope that the proceedings will be found useful by the competent fisheries authorities and organizations in their search and endeavours at the consolidated development of fishing industry.

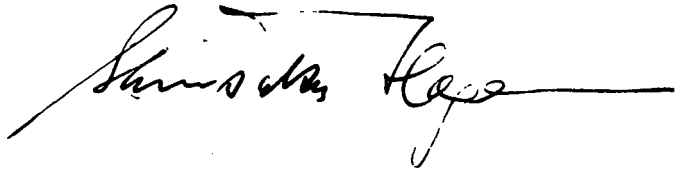

Shinsaku Hogen
President
Japan International
Cooperation Agency

February 1, 1977

FORWARD

For some considerable time the countries bordering the South China Sea have been aware of the need for more detailed knowledge of the fisheries resources of the South China Sea. At the Fourteenth Session of the Indo-Pacific Fisheries Council (IPFC), 1970, it was recommended that the Southeast Asian Fisheries Development Center (SEAFDEC) or some other regional body organize a technical seminar on matters pertaining to the South China Sea and make available to the IPFC the results arising from such efforts.

With the approval of the Council of SEAFDEC at its Fifth Meeting, 1972, the Technical Seminar on South China Sea Fisheries Resources was convened by the Center in Bangkok from 21 to 25 May 1973. In a joint effort, the technical aspects of the Seminar was arranged by the Marine Fisheries Research Department of the Center while the organization of the Seminar was carried out by the Secretariat.

It was gratifying to note that the Seminar was very successful with active participation of participants from countries bordering the South China Sea.

The Publication of the Seminar Proceedings, which has been delayed for two years by the limitation of funds, is now made possible by a generous contribution from Japan International Cooperation Agency (JICA).

On behalf of the Southeast Asian Fisheries Development Center, I wish to express my heartfelt thanks to JICA for their assistance and sincerely hope that the knowledge gained from this important Seminar will be useful for future fishery development planning and for the management of the fisheries resources and fisheries of the countries in the region.

I would like to take this opportunity to thank the staff of the Secretariat, the Training Department and the Marine Fisheries Research Department, particularly Drs. S. Shindo and O. Suzuki and Mrs. Francesca Sreesangkom for their efforts in compiling the texts of the Proceedings. Thanks are also due to Mr. Pisit Ngam-ngod of the Marine Fisheries Laboratory, Department of Fisheries, Bangkok, for his preparation of the text figures.



Deb Menasveta
Secretary-General

Bangkok
21 January 1977

CONTENTS

	Page
Introduction	1
Part I Country reports	2
Malaysia	2
Republic of the Philippines	6
Republic of Singapore	18
Kingdom of Thailand	19
Republic of Vietnam	24
Part II Technical papers	26
The pelagic resources	26
Bureau of Fisheries A plan for the development of sea fisheries in the Philippines	26
Kikawa, S. Tuna and tuna-like fish resources in the South China Sea and its adjacent waters	31
Kurogane, K. Some considerations of research and study on pelagic fishery resources	41
The demersal resources	43
Suzuki, O. A rational survey method for evaluation of trawl fishing ground	43
Suzuki, O. Fish school structure of red snappers and bigeye snappers in the South China Sea	46
Shirota, A. & Ratanachote, A. Preliminary observation on the distribution and catch of the shovel-nosed lobster, <i>Thenus orientalis</i> LUND in South China Sea	49
Senta, T., Tan, S.M. and Lim, P.Y. Results of the experimental trawl in the South China Sea by R/V CHANGI in the years 1970 to 1972	52
Senta, T. & Peng, C. C. Studies on the feeding habits of red snappers, <i>Lutianus sanguineus</i> and <i>L. seabae</i>	63
Senta, T. & Tan, S.M. Trawl fishing grounds in North Andaman Sea	66
Senta, T., Miyata, C. and Tan, S.M. Demersal fish resources in untrawlable waters, viewed through vertical-line fishing	70
Senta, T., Kungvankij, P. and Tan, S.M. Biological study of red snapper, <i>Lutianus sanguineus</i>	78
Shirota, A. Records of echo-sounder tracing as guide to locate and evaluate good fishing grounds	85
Hooi, K.K. A study of the catch data of the JURONG in the South China Sea in 1971 and 1972	88
Liu, H.C. The demersal resources of the South China Sea	94
Aoyama, T. Research on demersal fishes on the continental slope in the northern part of the South China Sea; the cruise result of R/V KAIYO-MARU	99
The fisheries oceanography	100
Suzuki, O. Fishing condition and its oceanographic interpretation in bottom longline fishing grounds	100
Suzuki, O. and Hooi, K.K. Behaviour of the warm-water mass along the east coast of the Malay Peninsula	103
Lim, L. C. Preliminary report on the distribution of chaetognaths in the southern part of the South China Sea	106
Shirota, A. Some consideration on the relationship between environmental factors and the distribution of fisheries resources in the South China and the Andaman Sea	111
Shirota, A. Brief note on the relationship of scattering layer and some hydrobiological factors	115
The current status of fisheries including statistics	117
Yamamoto, T. Current status of fisheries development in South China Sea area	117
Yamamoto, T. Fisheries statistics required for the stock assessment of fisheries resources in South China Sea area	120
Chen Foo Yan & S. Mito Current status of research activities of the Marine Fisheries Research Department, SEAFDEC	125
Flores, E. C. Harvesting of marine resources in the Philippines	130
Yamamoto, T. Problems other than fisheries resources in the South China Sea	133

Ha-Khac-Chu	Fisheries of Vietnam	138
The others		139
Seow, P.C. and Tay, G.	Preliminary observations on the utilization of pig-dung effluent for fish production	139
Caces-Borja, P.	The sea weed industry of the Philippines	142
Iwakiri, S.	Economic and social aspects of the resources	145
Kuronuma, K	Partial bibliography on biology and culture of penaeidean shrimps and prawns in Asia	145
Nishioka, Y. and Yamazaki, T.	Major fishery in Thailand and some technical recommendations for their improvement	146
Part III Record of discussion		155
The pelagic resources		155
The demersal resources		156
Other resources including aquaculture and minor sea products		157
Economic and social aspects of the resources		158
Part IV Recommendations		159
Annexes		161

INTRODUCTION

In consideration of a recommendation made in the Fourteenth Session of the Indo-Pacific Fisheries Council, the Council of the Southeast Asian Fisheries Development Center (SEAFDEC) approved at its Fifth Meeting, in Bangkok, June 6-10, 1972 that the Center organize a technical seminar on fisheries resources in the region.

The Technical Seminar on South China Sea Fisheries Resources was, therefore, convened in Bangkok, Thailand from May 21 - 25, 1973 under the sponsorship of the Southeast Asian Fisheries Development Center.

The Seminar was attended by participants nominated by all member countries of SEAFDEC and fisheries scientists from Chulalongkorn University, Kasetsart University, National Taiwan University and Food and Agriculture Organization of the United Nations. A list of participants appears as Annex 1.

OPENING CEREMONY

The Seminar was convened in the Operation Information Center of Chulalongkorn University, Bangkok at 9:30 hours on Monday May 21, 1973. The Opening Ceremony was presided over by H.E. Air Chief Marshal Dawee Chullasap, the Minister of Agriculture and Cooperatives. Dr. Arporn Sribhibhadh, the Secretary-General of SEAFDEC gave a brief report on the establishment and activities of the Center, and the objectives of the Seminar. Dr. Arporn's statement appears as Annex 2.

The Secretary-General invited H.E. Air Chief Marshal Dawee Chullasap, Minister of Agriculture and Cooperatives of the Government of Thailand, to deliver the opening address. In his speech, H.E. the Minister stressed the significance of fisheries resources in the economic development of the countries in this region, and indicated that the Government of Thailand had accorded high priority to the highsea fisheries development program in its national economic and social development plan, the implementation of which requires good knowledge of the resources as well as well-trained and skilled personnel, modern fishing technology and equipment. He further expressed the continued support of his Government to the Center and its regional cooperative undertakings. The text of H.E. the Minister's speech appears as Annex 3.

TECHNICAL SESSION

The Convenor of the Seminar, Mr. Felix R. Gonzales, the SEAFDEC Council Director for the Republic of the Philippines resumed the meeting in technical session at 10.30 hours, and was elected Chairman of the Meeting.

The Seminar consisted of five sessions under the following headings:

- Session I. Pelagic Resources (Offshore and Inshore)
- Session II. Demersal Resources (Offshore and Inshore)
- Session III. Other Resources Including Aquaculture and Minor Sea Products
- Session IV. Economic and Social Aspects of the Resources
- Session V. Recommendations

A list of papers appears as Annex 4.

CLOSING OF THE SEMINAR

Mr. Pedro Acosta (Philippines), on behalf of all participants, and Dr. J.A. Gulland (FAO), on behalf of the observers, thanked the Government of Thailand and Chulalongkorn University for providing facilities, the Southeast Asian Fisheries Development Center for sponsoring the Seminar and the Convenor and secretariat staff for their untiring efforts which had contributed to the successful conclusion of the Seminar.

Mr. I. Ronquillo (Philippines) thanked the discussion leaders, rapporteurs, participants and observers for their cooperation.

ADOPTION OF THE REPORT

The Seminar adopted this report on May 25, 1973.

PART I COUNTRY REPORTS

SEAFDEC/SCS.73:S-22

The country report of the Malaysia

Status of the Marine Fisheries with Assessments of Potential Yields from the Coastal Marine Fisheries Resources of Malaysia

by
D. Pathansali
Fisheries Division
Ministry of Agriculture and Fisheries, Malaysia

1. INTRODUCTION

In the presentation of the country report the marine fisheries of the coastal waters of the west and east coasts of West Malaysia are treated separately as the marine fisheries resources of the two coasts are quite distinct and the rates of growth of the fisheries dissimilar. The data utilised cover the period 1965 to 1971 for prior to 1965 detailed statistics of catch landings are not available and there was little if any trawling.

The data on catch landings are considered under two groups, the major group comprising the demersal and semi-pelagic species, pelagic schooling species such as chub mackerel, anchovies, tunas, sardine and herrings, trevally, round scad and yellow banded scad, prawns and the minor group comprising shrimps, crabs squids and cuttle-fish, bivalves and other molluscs. The description of the status of the marine fisheries and the assessments of the potential yields are based mainly on the major group.

2. STATUS OF MARINE FISHERIES

2.1 West coast (Table I, Figure I)

Total marine fisheries landings increased insignificantly during the years prior to 1965 but thereafter increased rapidly at an accelerated rate to a peak in 1968 of 278,151 tons, declined through 1969 and 1970 to 230,539 tons and recovered somewhat in 1971 to 249,147 tons. The trends shown were due partly to the additional landings of demersal and semi-pelagic species following the introduction and expansion of trawling since 1965 but mainly to the exceptional abundance of *Rastrelliger spp.* in the coastal waters during 1967 and 1968. The trends shown by the major and minor groups were as follows:

2.1.1 Demersal and semi-pelagic species.

Landings of this group increased from 63,826 tons in 1965 to 102,355 tons in 1968, decreased to 83,605 tons in 1970 and increased to 96,214 tons in 1971. The contribution by trawlers increased from 17 percent in 1965 to 63 percent in 1971 whilst the contribution by traditional gears decreased from 83 percent in 1965 to 37 percent in 1971.

2.1.2 Pelagic schooling species.

Landings of this group increased from 29,839 tons in 1965 to 115,759 tons in 1968, decreased to 68,527 tons in

1970 with the 1971 landings just slightly higher at 70,120 tons. The landings of this group were greatly influenced by the landings of *Rastrelliger spp.* which increased from 8,598 tons in 1965 to 89,507 tons in 1968, the highest ever recorded for these species. The landing in 1971 increased somewhat over 1970 to 33,394 tons.

The landings of the other species of the group, on the other hand, increased from 21,241 tons in 1965 to 38,884 tons in 1970 but decreased slightly to 36,726 tons in 1971.

2.1.3 Prawns

Landings of prawns which were of the same order during 1965 and 1966, 13,191 tons and 13,797 tons respectively, increased at a greater rate thereafter as more and more trawlers switched over to prawns the following years. In 1971 total prawn landing was 45,934 tons with

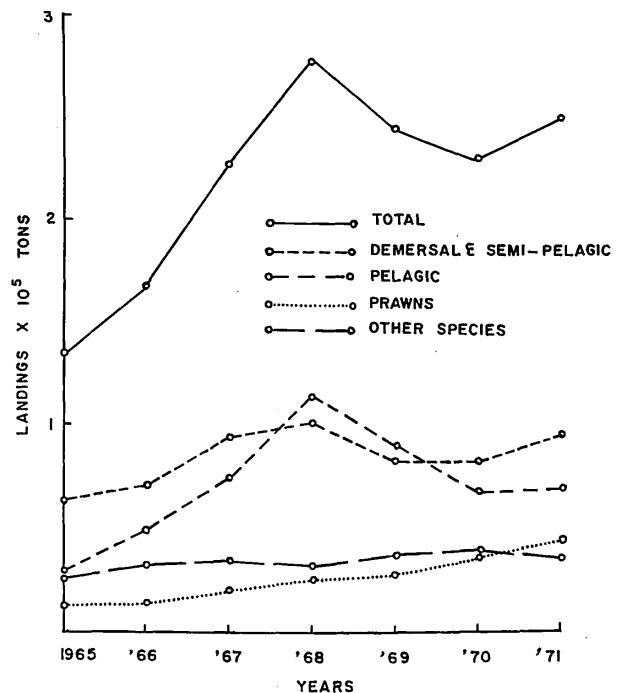

Fig. 1 Trends of marine fisheries landings, 1965 - 1971 on the west coast.

Table I

West Coast

Marine fisheries landings, 1965 – 1971, on the west coast of West Malaysia

	1965	1966	1967	1968	1969	1970	1971
1. Total	133,134	166,668	226,690	278,151	243,620	230,539	249,147
2. Demersal & semi-pelagic	63,826	71,510	94,751	102,355	84,000	83,605	96,214
2.1. By trawlers	11,061	21,450	53,577	47,257	37,636	43,191	60,951
2.2 Traditional gears	52,765	50,060	41,174	55,098	46,364	40,414	35,263
3. Pelagic	29,839	49,274	75,504	115,759	91,041	68,527	70,120
3.1. <i>Rastrelliger</i> spp.	8,598	18,800	49,907	89,507	56,367	28,643	33,394
3.2. Other spp.	21,241	30,474	25,597	26,252	34,674	38,884	36,762
4. Prawns	13,194	13,797	21,573	26,276	29,652	37,544	45,934
4.1. By trawlers	—	—	—	9,260	9,167	22,405	30,612
4.2. Traditional gears	13,194	13,797	21,573	17,016	20,485	15,139	15,322
5. Shrimps	4,557	5,450	5,711	3,336	6,753	5,305	4,805
6. Crabs	1,408	1,603	1,674	2,033	2,436	1,652	1,457
7. Squid & Cuttlefish	366	508	697	1,401	1,342	2,085	1,718
8. Bivalve	19,070	24,086	26,426	26,546	27,786	31,159	28,168
9. Other molluscs	874	440	354	445	610	662	731

the trawlers contributing 30,612 tons, twice that of traditional gear. Traditional gear landing reached a peak 20,485 tons in 1969 but the landings in 1970 and 1971, just over 15,000 tons, were only slightly greater than the 1965, 1966 landings. (The 1967 landing by traditional gear includes landing by trawlers).

2.1.4 Minor groups.

The most important in this group is the bivalve, *Anadara granosa*, cultured on estuarine and coastal mud-flats. Landings increased from 19,020 tons in 1965 to 31,159 tons in 1970. In 1971 it decreased somewhat to 28,168 tons. Next in importance are the shrimps, *Acetes* spp, which increased from 4,557 in 1965 to 6,753 tons in 1969 and decreased to 4,805 tons in 1971. Crabs increased from 1,408 tons in 1965 to 2,436 tons in 1969 but decreased to 1,457 tons in 1971. Squid and cuttlefish showed a similar trend, increasing from 366 tons in 1965 to 2,085 tons in 1970 but decreasing to 1,718 tons in 1971. The greater part, over 95 percent of the landing, of squid and cuttlefish is by trawlers. The other molluscs decreased after 1965 when 874 tons were landed but recovered gradually to 731 tons in 1971.

2.2 East coast (Table II, Figure II)

Total marine landings remained more or less stagnant throughout the period 1965 to 1971. Landings increased from 65,243 tons to 75,166 tons in 1968, decreased to 54,220 tons in 1969 and increased again to 68,826 tons in 1971. The trends shown by the major group, the minor group's contribution being negligible, were as follows:

2.2.1 Demersal and semi-pelagic species.

Landings of this group increased from 23,959 tons in 1965 to 35,102 tons in 1971 with some fluctuations during the intervening years. The increase was primarily due to the development of trawling, at a modest rate during the earlier years and at a more rapid rate during the latter years of the period. Landings by trawlers increased from 1,967 tons in 1965 to 16,555 tons in 1971 whilst landings by traditional gear decreased from around 29,000

tons in 1966, 1967 to 18,548 tons in 1971. This decrease was due not to the reduction in the resource but to the decline in the amount of traditional fishing gear for reasons unknown.

2.2.2 Pelagic schooling species.

Landings of this group decreased from 37,562 tons in 1965 to 24,556 in 1970 but increased to 28,298 tons in 1971. Again, as for the demersal and semi-pelagic species, the decrease is attributed to the decrease in the amount of traditional fishing gear. *Rastrelliger* spp. decreased from 10,144 tons in 1965 to 4,756 tons in 1971 whilst the other species decreased from 27,418 tons in 1965 to

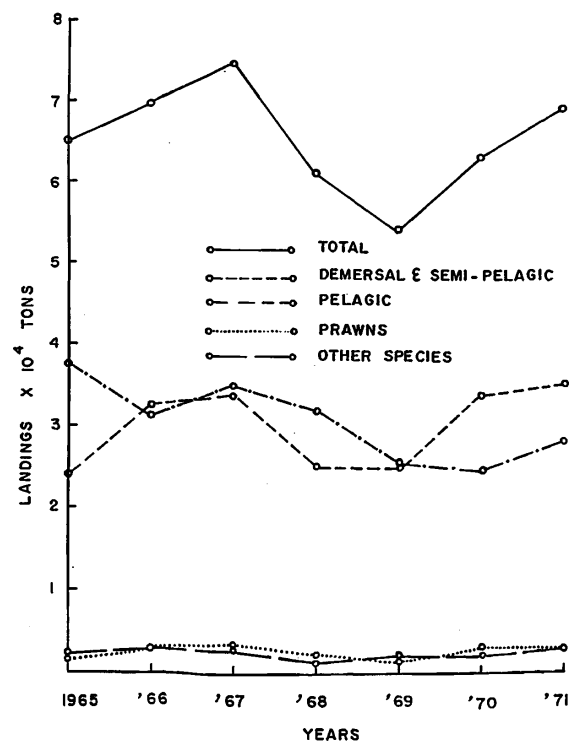

Fig. 2 Trends of marine fisheries landings, 1965 – 1971 on the east coast.

Table II

East Coast

Marine Fisheries Landings, 1965 – 1971, on the East Coast of West Malaysia

	1965	1966	1967	1968	1969	1970	1971
1. Total	65,243	69,939	75,166	61,331	54,220	63,757	68,826
2. Demersal & semi-pelagic	23,959	32,651	34,169	25,295	25,014	33,985	35,103
2.1. By trawlers	1,967	3,029	4,547	5,179	7,045	14,084	16,555
2.2. Traditional gears	21,992	29,622	29,622	20,116	17,969	19,901	18,548
3. Pelagic	37,562	31,386	34,597	31,964	25,484	24,556	28,298
3.1. Rastrelliger spp.	10,144	6,544	7,382	4,527	4,593	5,337	4,756
3.2. Other spp.	27,418	24,842	27,215	27,437	20,891	19,219	23,542
4. Prawns	1,598	2,987	3,425	2,481	1,628	3,120	2,535
4.1. By trawlers	—	—	—	1,397	723	2,092	1,800
4.2. Traditional gears	1,598	2,987	3,425	1,084	905	1,028	735
5. Shrimps	1,086	1,808	1,033	280	720	341	873
6. Crabs	106	343	542	116	111	433	153
7. Squid & Cuttlefish	832	757	1,400	1,195	1,263	1,322	1,864
8. Bivalve	—	—	—	—	—	—	—
9. Other molluscs	100	7	—	—	—	—	—

19,219 tons in 1970 but increased to 23,542 tons in 1971.

2.2.3 Prawns

Landings of prawns fluctuated between 1,500 tons to 3,500 tons with trawling contributing 50 per cent and more towards the landings. The fluctuations were due mainly to the effect of the prevailing conditions during the north east monsoon, when prawns are in season, on the trawling activity for prawns.

3. MAGNITUDE OF THE MARINE FISHERIES RESOURCES AND POTENTIAL YIELDS

The estimations of the magnitude of the marine fisheries resource and potential yields are difficult as catch and effort data in the present form are not altogether suitable and reliable for such estimates. Some reasonably good data available for the trawl fishery of the northern states on the west coast and the results of demersal trawl surveys are utilised together with observations on trends of the landings during the period and their density over the fished areas to arrive at some, hopefully, reasonable estimates.

3.1 West coast (Figure III)

3.1.1 Demersal and semi-pelagic species.

Estimate of maximum yield, using the surplus yield model, for the northern states for which some fairly reliable catch and effort data are available is 40,527 tons similar to the landing of 40,191 tons giving a yield per square nautical mile of 13.5 tons for waters up to a depth of about 50 meters, a figure slightly higher than Tiews 12.3 tons. The figure is probably on the high side as a mesh size of 1 inch and less is used in the cod end of the trawl nets. Nevertheless this figure is used in estimating the potential maximum yield for the northern states. For the southern states where trawling is just being developed the potential maximum yield is based solely on a potential yield of 3.8 tons per square nautical mile derived from a recent trawl

survey of the waters of the southern states.

A rough estimate of the maximum yield, using the surplus yield model, for the whole west coast is between 55,000 to 58,000 tons. The estimate using density figures of 13.5 tons per square nautical mile for the northern states and 3.8 tons per square nautical mile for the southern states is 59,136 tons, the two estimates being similar. These estimates do not include the semipelagic species only partially taken by trawlers. Landings of demersal and semi-pelagic species by traditional gears decreased after 1968 to 35,263 tons in 1971. It is unlikely that the landings will decrease below this figure as trawling

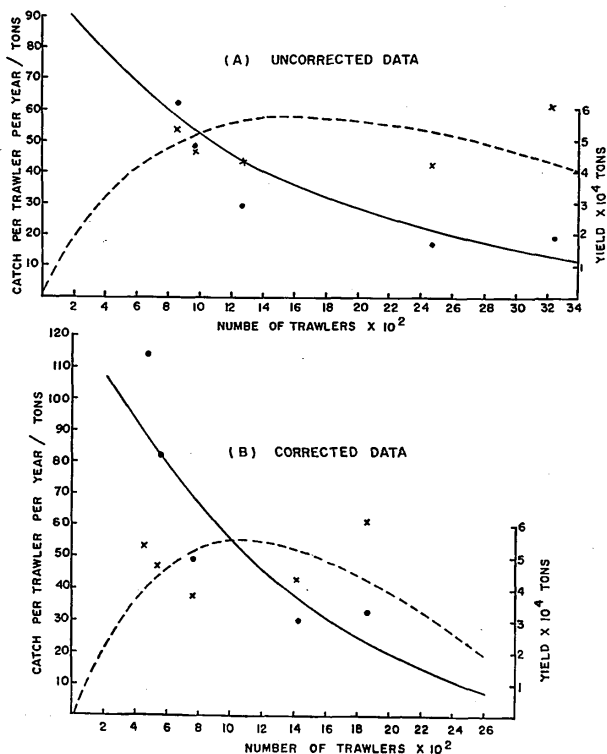

Fig. 3 Maximum yield driven from catch and effort data for the west coast.

is already well developed and is not likely to affect the landings of traditional gear appreciably. Nor, on the other hand, it is likely to increase further unless there is a change in the stock abundance of the species. If this figure of 35,263 tons is added to the estimates of 55,000 and 59,000 tons the total maximum yield will be in the range of 90,000 to 94,000 tons. The estimated range, though it does not differ significantly from the 1971 landing, could be high and should be reduced by some 10–20 per cent as the mesh size of the cod end of fish and shrimp trawls is 1 inch and less and the percentage of trash fish is high, about 50 percent for fish trawlers and between 64 to 84 percent for prawn trawlers. As a matter of interest an estimate of potential yield using Tiew's figure is about 80,000 tons, not significantly less than the estimate derived above, considering the reliability of the data used.

3.1.2 Pelagic schooling species.

There are no good data of catch and effort and the estimates made are based on trends during the period 1965 to 1971. *Rastrelliger spp*, the major pelagic species, had fluctuated 10-fold without any significant increase in effort from a maximum of 8,598 tons in 1965 to 89,507 tons in 1968. The best estimate of sustained yield would be the average of the landings over the period 1965 to 1971, some 41,000 tons. The other species, with the exception of the anchovies, are not fully exploited due mainly to the effect of trawling on the method of fishing carried out for these species. It is likely that landings of these species could be increased by a minimum of 5–10 percent over the landings of the last 3 years of the period to about 40,000 tons to give a total maximum yield of pelagic schooling species of about 81,000 tons.

3.1.3. Prawns.

As prawns have shown an increasing trend throughout the period it has not been possible to use catch and effort data to estimate maximum yield. Landings by trawlers in 1972, available for the northern states, increased in some states and decreased in others to give a net decrease of some 5,000 tons. It is therefore unlikely that prawns landed by trawlers will increase and even if they do they will most likely encroach on the landings by the traditional gear. Landings by traditional gear are not expected to increase in the face of competition by trawlers. It would appear that the landings are somewhat overestimated especially as landings were estimated proportionally to the gear operated. The maximum yield is probably in the region of 40,000 to 45,000 tons. This is somewhat higher than the 35,000 tons estimated by Gulland(FIRS/T97).

3.1.4 Minor groups

It is not expected that there will be any significant increase in the landings of the species comprising the minor group. Maximum yields estimated is between 38,000 to 40,000 tons.

3.2 East coast

3.2.1 Demersal and semi-pelagic species.

The estimate of potential yield is based on the results of 3 demersal trawl surveys carried out in depths ranging from about 10 meters to 50 meters. Assuming a 50 percent escapement of fish the estimate of standing stock is 161,000 tons. This would also be the maximum yield but

Table III

Average landings, 1971 landings and potential yields from marine fisheries

(a) West Coast

	Period averaged	Average landing	1971 landing	Potential yield
1. Demersal and semi-pelagic species	1967–1971	92	96	90–94
2. Pelagic schooling species	1965–1971	71	70	81
3. Prawns	1971	46	46	40–45
4. Other species	1969–1971	39	37	38–40
5. Total		248	249	249–260

(b) East Coast

1. Demersal and semi-pelagic species	1970–1971	30	35	95–130
2. Pelagic schooling species	1965–1971	31	28	56–75
3. Prawns	1965–1971	2.5	2.5	5–6
4. Other species	1965–1971	2.4	1.9	3–4
5. Total		65.9	67.4	159–215

because of the quality of the resource and its variable density with time it is not likely that the whole of the trawlable areas will be evenly exploited. As such a more reasonable estimate of maximum yield is between 80,000 to 120,000 tons. Landings by traditional gear decreased after 1967 to 18,548 tons in 1971. As trawling expands it is most likely that landings by traditional gear would be between 95,000 to 130,000 tons.

3.2.2 Pelagic schooling species

The highest landing recorded is 37,562 tons in 1965 when it was considered that the fisheries for the species were under developed. During the following years the landings declined but recovered somewhat in 1971. The anchovies declined the most due to the decrease in the number of beach seines following a change-over to other more productive traditional gear for other species. From reports and observations it appear that there are fairly substantial stocks of pelagic schooling species that could give a potential yield 1.5 to 2.0 times the landing of 1965, between 56,000 to 75,000 tons and perhaps even more, in the coastal waters if better and more efficient methods of fishing could be developed and or introduced.

3.2.3 Prawns

Landings depended partly on coastal semi-resident stocks which show seasonal variation and partly on migrant stocks which appear in the coastal water during the period of the northeast monsoon. Whilst the former stocks are fairly well exploited the latter stocks appear to be inefficiently exploited. As such, the potential yield possible is estimated to be around 5,000 to 6,000 tons.

3.2.4 Minor groups

It is unlikely that maximum yield will be greater than the landing of 2,590 tons in 1971 but more efficient methods of exploiting cephalopods could increase the maximum yield to between 3,000 to 4,000 tons.

3.3 Other areas

3.3.1 East Malaysia

An estimate of potential yield is made for demersal and semipelagic species only based on the results of a single demersal trawl survey in the coastal waters up to about 50 meters. The estimate is 183,000 tons but is more likely to be between 91,500 to 137,250 tons. The potential yield per square nautical mile of 10.6 tons is similar to that of the east coast of West Malaysia, 10.3 tons.

3.3.2 Deeper waters

(a) West coast of West Malaysia

In waters deeper than 50 meters the average catch rate of about 92.0 kg per hour was lower, about 64% of the

catch rate in waters shallower than 50 meters which are fairly well exploited, and with a potential yield of 3.0 tons per square nautical mile.

Unless very efficient gear, such as pair trawling, can be employed to exploit successfully this sparse resource it is not expected that major fishery can be developed.

(b) East coast of West Malaysia and East Malaysia

The estimate of potential yield is comprehensively dealt with by Shindo (IPFC/72/19) and as the average density is low, though in some areas it is higher than others, the problem of developing major fisheries for these demersal fish stocks is similar to the one discussed above for the west coast of West Malaysia.

SEAFDEC/SCS. 73: S-23

The country report of the Republic of the Philippines

Technical Seminar on South China Sea Fisheries Resources

by

The Philippine Bureau of Fisheries
Department of Agriculture and Natural Resources
Republic of the Philippines

1. INTRODUCTION

Since the inshore demersal and pelagic fisheries of the Philippines are already highly exploited, it is but timely that the country avail itself of the benefits that are expected to be derived from the South China Sea. Moreover, Kvaran (1971) noted that during the last twenty years, the landings from the marine fisheries have largely increased in the Southeast Asian Countries and more so in the Philippines so that the country is probably already harvesting a large percentage of its potential yield in its inland seas and territorial seas. Thus, the Philippine fisherman should be encouraged to expand fisheries, particularly the trawl fishery, into under-exploited international waters like the South China Sea.

It is envisioned that more knowledge would lead to an optimum utilization of the resources of the South China Sea.

This paper aims to give a picture of the status of the fisheries resources of the Philippines.

1.1 The Geographical Setting

The Philippine Archipelago situated in the outer rim of the Western Pacific is composed of 7,100 islands with a land area of 299,404 square kilometers. Eleven large islands make up more than ninety per cent of this area; only 45 islands have areas greater than 100 square kilometers, the largest being Luzon in the north and the second largest, Mindanao in the south. The major portion of the island group lies within an elongated ellipse extending north-northwest to south-southeast. Palawan and the Sulu Archipelago break away from this main body in a southwesterly direction toward Borneo to form the northwest and southwest boundaries of the Sulu Sea.

The whole Philippines is spread within a territorial¹⁾ area of about 1,965,700 square kilometers lying between latitudes 21°25'N and 4°23'N and longitude 116°00'E and 127°00'E. It is bounded on the east by the Pacific Ocean, on the south by the Celebes Sea and the coastal waters of Borneo, and on the west and north by the China Sea, which separates it from the Asiatic mainland.

The Philippines has limited continental shelves, the 200-meter isobar varying from 1 mile to about 60 miles in the Sulu Archipelago. In most parts of the archipelago it is just 31 to 45 miles from the shore.

A number of seas surround the islands, and these range from deep troughs and trenches to shallow basin and coral reefs. There are four deep regions of the marine area: one off east of Luzon up to the southeast of Taiwan (3000 fathom); another in the Sulu Sea (3,049); a third in the Celebes Sea (2786 fathom); and the fourth, the Philippines deep east of Samar and Mindanao (10,790 meters).

Philippine waters in relation to land area are extensive (about 5 times the land in surface area) but the insular shelves, the present seat of commercial fishing, are narrow and steep. Shallow waters with depths to 200 meters and up to about 165,000 square kilometers which are limited around the islands. Large portions of the shelf cannot be trawled due to the growth of coral reefs. Fishing for pelagic fish species takes place in shallow waters during strong monsoon winds and in most waters during calm weather.

From the standpoint of oceanography, the Philippine

1. Area as defined in the Treaty of Paris in 1898 between the United States of America and Spain.

Archipelago forms a topographic unit separating the South China Sea from the Pacific Ocean. It stands on a roughly triangular platform with its base forming a natural boundary between the Philippine and Indonesian seas, and its apex pointing northward in the direction of Taiwan and the Ryukyu chain of islands with which the Philippine are linked geologically. Within the platform are various depressions or basin seas in which the bottom water is not in communication with that of the Pacific Ocean to the east nor with that of the South China Sea to the west.

These basin seas are themselves separated oceanographically from one another by definite topographical boundaries which are marked off by the submarine ridges which define the respective limits of the eight basins or oceanographic provinces comprising the internal waters of the Philippines.

By and large because of depth of the surrounding water and distance from the mainland of Asia and its great rivers, the waters surrounding the Philippines are biologically poor compared to temperate waters.

1.2 The Importance of Fisheries to the Country's Economy

Fish is one of the basic foods of the Philippines, second only to rice, the leading staple crop, in importance. The daily diet of the people consists therefore of rice and fish, the latter as the main source of animal protein in the country. The per capita consumption of fish is about 36.5 kilograms of fish/year, which is more than twice the world's average.

In 1971, 67% of the animal protein consumed by the people came from fish. The annual production of fish, however, has not met the requirement of the fast-growing population of the country (Table I). In 1971, for example, the total fish output of 1 million metric tons supplied only about 73.8% of the nutritional fish needs of

the people. To partly fill the deficiency, the country had to import 19,000 m.t. of fish and fisheries products valued at some US \$20 million. More than 90% of the fish produced in the country comes from the marine fisheries.

Fishery is one of the most important elements of Philippine economy. In addition to supplying food, it produces income, provides employment and earns foreign exchange which is badly needed in the economic development of the country. In 1969-1970, the gross value added in fisheries amounting to P1544 million (U.S. \$238.3) contributed 3.91% of the national income and formed 10% of the income derived from the agricultural sector of the economy.

About 700,000 persons are employed in the fisheries industry forming about 4.05 of the total labor force of the country. In view of the drive of the Government for increased food production, more capital is channeled into the fisheries investment stream and more opportunities for employment are created.

The Philippines is fast developing its export trade in fish and fisheries products. In 1970, the total export of fisheries products was only U.S. \$3 million and reached to almost U.S. \$7 million in 1971. During the first half of 1972, the amount of U.S. \$5 million was already attained.

1.3 Fishery Resources

The fishery resources of the country consist of more than 2,200 species of fish which may be grouped into bottomliving (demersal) and free-swimming (pelagic) fishes. However, only less than 100 are of economic importance.

The eighteen (18) commercially important fishes by production are divided almost equally between the free-swimming (pelagic) and bottom-living (demersal) groups. Of the pelagic fishes, those that form important fisheries are roundscad (*Decapterus*), sardines (*Sardinella*), anchovies (*Stolephorus*), chub mackerel (*Rastrelliger*) and

Table I
Fish Requirement and Available Supply (Fish Production and Imports)

Year	Fish Production in Metric Tons	Fish Requirement in Metric Tons	Fish Consumption in Metric Tons	Imports of Fish and Fish Products (M.T.)	Imports of Fish and Fish Products (\$)	Population
1952	313,060	527,112	335,711	23,843	7,853,302.00	21,533,000
1953	305,626	537,130	334,810	31,165	9,954,597.00	22,191,000
1954	343,625	547,340	366,722	26,345	5,851,814.40	22,869,000
1955	362,927	552,994	411,183	50,286	10,523,574.40	23,568,000
1956	393,648	563,533	436,458	45,964	8,038,623.57	24,288,000
1957	387,170	579,722	439,393	56,315	9,843,850.00	25,030,000
1958	426,666	590,722	488,301	65,229	10,713,913.33	25,795,000
1959	436,481	635,491	478,710	47,304	7,323,010.00	26,584,000
1960	444,622	740,483	528,033	86,539	12,693,426.28	27,387,000
1961	454,899	774,767	520,008	74,630	8,994,989.00	28,212,000
1962	483,948	800,955	515,947	38,370	9,193,818.00	29,062,000
1963	547,354	830,922	593,137	49,850	13,885,220.00	29,937,000
1964	603,506	954,210	643,278	49,439	14,400,076.92	30,839,000
1965	667,202	991,698	709,471	51,731	15,423,003.00	31,768,000
1966	705,278	1,026,414	746,260	50,120	14,877,148.00	32,725,000
1967	746,063	1,062,553	796,841	67,689	17,733,312.67	33,711,000
1968	937,684	1,309,729	1,001,802	88,291	20,159,243.27	34,726,000
1969	940,792	1,356,267	985,476	71,034	15,549,575.40	35,772,000
1970	998,884	1,338,984	1,040,005	62,746	18,019,829.00	36,648,486
1971	1,023,095	1,386,380	1,076,715	68,883	20,406,703.	37,919,096

tunas (skipjack, yeito tuna, yellowfin tuna and frigate mackerels). Their production formed 53% of the total commercial fish output of the country in 1971.

The most important demersal species are the slipmouth (*Leiognathus*), lizard fish (*Saurida*), *Caesio* and cavalla (*Caranx*). In 1971, their total landing was 83,645 tons corresponding to 21.88% of total commercial production.

The free-swimming fishes are mainly caught by purse seine, bagnet, and round haul seines while the bottom-living species are fishes mainly caught by otter trawl, beach seine, gill net, drive-in-net and hook and line.

Of the 15 most important fishing grounds about one-half are with depths of less than 100 meters. These are the Sulu Sea, Visayan Sea, Manila Bay, Sibuguey Bay, San Miguel Bay, Davao Gulf, Samar Sea, Guimaras Strait, Ragay Gulf, Sarangani Bay, Moro Gulf, Tayabas Bay, Batangas Coast and the Babuyan Channel. The poor productivity of the internal waters is closely related to the depth.

Studies undertaken since 1957 indicate the very low catch per unit of effort of our trawl fishery which is about 15 kilos per hours in the most important trawling ground of the country (Manila Bay) and about 35 kilos in other parts of the country.

1.4 Fisheries Industry

The fisheries industry of the country is arbitrarily divided into municipal, commercial and inland.

1.4.1 Municipal Fisheries

There are about 50,000 sustenance fishermen using small boats (not more than 3 gross tons) which make up the municipal fishery and produced in 1971 some 542,904 metric tons of fish. These made up 53.06% of the total production that year.

It is estimated that there are probably as many as 271,000 fishing boats in the municipal fishery of which one-fifth is motorized.

1.4.2 Commercial Fisheries

In 1971, there were about 2,180 licensed commercial fishing vessels that were in operation whose tonnages ranged from 31 to 600 G.T.; they operated from 50 to 800 km from the home port. There were some 1,880 vessels of over 3 gross tons which produced 382,276 metric tons of fish (more than 37%). Roundscad forms one of the most important catones of the fishery totalling some 142,921 metric tons in 1971.

Bagnet and purse seine catches formed more than 53% of the total catch of commercial fishing vessels in 1971.

1.4.3 Inland Fisheries

About 168,000 hectares of swampland have been developed into brackishwater fishponds which are used primarily for the culture of milkfish (*Chanos chanos*).

This produced some 100,000 tons of fish in 1971 valued at about U.S. \$41 million and supplied about 10% of the total fish production of the country. About 170,000 people are employed in this fishery.

The development of freshwater fishponds is just beginning, and is given priority by the Government.

2. PELAGIC RESOURCES (OFFSHORE AND INSHORE)

2.1 Fish Species

The pelagic (free-swimming) fish species in the Philippines which number more than 25 species are usually caught by purse seines and bag nets. The most common and commercially important of these are roundscads (*Decapterus spp.*); sardines (*Sardinella sp.*); chub mackerels (*Rastrelliger spp.* and *Scomber spp.*); Spanish mackerels (*Scomberomorus commersonii*); anchovies (*Stolephorus spp.* and *Engraulis*); several species of cavallas (*Caranx*); big-eyed scales (*Caranx crumenophthalmus*); yaito tuna (*Euthynnus yaito*); skipjack (*Katsuwonus pelamis*); yellow fin tuna (*Thunnus albacares*) and frigate mackerels (*Auxis*).

2.2 Fishing Grounds

The major grounds of these pelagic species are concentrated in the coastal and shallow seas between the islands throughout the country. These are the northern Palawan area, Manila Bay, Sulu Sea, Visayan Sea, the Sibuyan Sea, Sibuguey Bay, Tayabas Bay, Davao Gulf, Lamon Bay and Samar Sea.

During the South West monsoon months (June to October), fishing for pelagic fishes takes place in shallow waters and during calm weather in most open waters. The tropical storms from June through December usually originate well to the east of the Philippines. This naturally prevents extensive exploitation of the pelagic fish resources in the area east of the Archipelago. In Palawan Area operations are concentrated on the northern section during the southeast monsoon season and to the western coast during the northeast monsoon season. During the trade wind season, March to May, quite a number of bagnetters operate in the southeastern part of Luzon.

2.3 Fishing Gear

Commercial pelagic fishing commonly makes use of light. This started with the use of Kerosene lamps in connection with the operation of round haul seine or *sapyaw*. Then in the sustenance fishery in the Visayan Islands, bagnet (*basnig*) and light (pressure kerosene lamps) quickly outpaced the round haul seine by 1935. However, both the round haul seine and the bagnet have been in continuous use until 1960. With the improvement of the bagnet through the use of brighter lights using electric generators and synthetic (*Kuralon*) nets, it became the second most important gear in the country in the late sixties. In 1971, there were more than 700 basinigan uniits of which about 50% is from 3 to 10 gross tons. These landed 85,861 metric tons of fish or 22% of the combined production of all commercial fishing vessels.

In the country, especially in Manila Bay, non-mechanized small purse seiners (the *talakop* and the *ku-kub*) had been used, especially for chub mackerel. But they proved inefficient and were surpassed by the basnigan. An active search for still better improvements in light fishing was made. In 1962, a private operator introduced a modern U.S. West Coast-type purse seiner equipped with Puretic power block. This used similar light methods as those used by the basnig vessels whereby they were used as light boats to concentrate the fish thru light.

In 1963, the purse seine expert of the FAO demonstrated the technical advantages in modern purse seining. This led other bat owners to shift to this type of fishing. In 1971, more than 200 units of modern purse seiners which range from 60 to 180 gross tons operated in the country. It is estimated that 117,684 metric tons of fish had been landed from purse seiners in 1971 which form about 31% of the total production of all commercial vessels of the country.

The rapid expansion of purse seine-basnigan fishing with light throughout the Philippines was made possible by the joint effort of the then Philippine Fisheries Commission and the FAO-UNDP Deep Sea Fishing Development Project with the cooperation of the private sector.

2.4 Fishing Seasons of the Major Species

The fishing operations for the different pelagic species vary in different places. These are shown below:

Pelagic Fishes and Their Fishing Areas and Seasons		
Fishes	Fishing Areas	Fishing Seasons
Roundscads (<i>Decapterus</i> spp.)	Palawan waters Batangas Bay Tayabas Bay Northern Zamboanga	March to August (April and May, peak)
Sardines (<i>Sardinella</i> spp.)	Manila Bay Visayan Sea Cynthia Bay and adjacent Islands, Palawan Brooks Point and Panacan, Palawan Malampaya Sound Southern Zamboanga Sulu Archipelago Panay Gulf	December to May Throughout the year (May to October, peak) December to May May to September Throughout the year December to May Throughout the year – Ditto –
Mackerels Into-Pacific Mackerels (<i>R.</i> <i>brachysoma</i>)	Manila Bay Malampaya Sound and vicinity Southern Samar Gigantes and Bantayan (Visayan Sea)	May to December May to September February to May April to October
Indian Mackerels (<i>R.</i> <i>chrysozonus</i>)	Eastern and Northern Palawan and vicinities Northeastern Palawan and Cuyo group Southern Zamboanga and Sulu Archipelago Visayan Sea	December to June April to November December to May April to October
<i>Scomber</i> spp. <i>Scomberomorus</i> <i>commersonii</i> (Spanish mackerel)	Manila Bay Cynthia Bay Malampaya Sound Visayan Sea Guimaras Strait Mindanao Area Zamboanga area	Throughout the year January through April – Ditto – – Ditto – Throughout the year – Ditto – – Ditto – – Ditto –

Cavallas (<i>Caranx</i> spp.)	Northern and Eastern parts of Palawan Panay Gulf Visayan Sea	March to October Throughout the year – Ditto –
Big-eyed scads (<i>Caranx</i> <i>crumenophthalmus</i>)	Lingayan Gulf Batangas Bay Balayan Bay Tayabas Bay Northern Palawan Visayan Sea Southern Zamboanga Sulu Archipelago	December to May – Ditto – – Ditto – – Ditto – May through October Throughout the year – Ditto – – Ditto –
Anchovies (<i>Stolephorus</i> spp.)	Manila Bay Balayan Bay Batangas Bay Coron and Gutob Bays Taytay Bay Tayabas Bay	November to May February to June – Ditto – Throughout the year May to September November to May
Tunas bonitos and frigate mackerels Yellowfin tunas	Northern Palawan Zambales Coast Balayan Bay Batangas Bay Off Lubang	December to June January to April November to June – Ditto – – Ditto –
Skipjack or oceania bonitos	West coast of Panay West Visayan Sea South Solu Sea	February to May March to June Throughout the year
Blue bonitos or yaitotunas	Off-Corregidor to Lubang and west coast of Mindoro Solu Sea Davao Gulf	January to May Throughout the year – Ditto –
Frigate mackerels	Northern and north- western Zambales Coast Sulu Archipelago Manila Bay Bantagas Bay Balayan Bay	January to May – Ditto – December to May November to May November to May

2.5 Fish Production

The bagnet and purse seine fishermen, numbering 19,136 in all, made up one-half of the total number of fishermen engaged in commercial fishing in 1971. Bagnet and purse seine catches of pelagic fish constituted more than 53 per cent of the total catch of the commercial fishing vessels in 1971.

The roundscads since 1963 have become the principal catch of the bagnet and modern purse seines. In 1971, some 142,921 metric tons or 37 per cent of the catch of commercial fishing vessels were roundscads. Based on the yearly production, the Sulu Sea was the richest fishing ground for this fish group forming 87 per cent of the total commercial fish production in 1971 (Table II).

The total catch of sardines which rank next in importance to the roundscads amounted to 44,086 metric tons or 11.5 per cent of the total commercial fish landed in 1971. Again the Sulu Sea was the richest fishing ground for this fish group with its production forming about 84 per cent of the total commercial fish production also in 1971.

As in the roundscads and sardines, the Sulu Sea was the principal fishing area for chub mackerels in 1971. Their production amounted to 19,992 metric tons or 5.2 per cent of the total commercial fish production.

Landings of the big-eyed scads (*Caranx crumenophthalmus*) amounted to 18,414 metric tons which are equivalent to 4.8 per cent of the total production of the commercial fisheries in 1971. Most of these landings were from the Visayan Sea and the Sulu Sea.

Among the pelagic fishes the anchovies mostly (*Stolephorus*) occupy only the fifth place in 1971, with a production of 7,400 metric tons or 1.9 per cent of the total production. This group which used to occupy the first place during the 1950's was mostly landed from Coron Bay, Manila Bay, Taytay Bay, and Sulu Sea.

In 1971, the Visayan Sea, Sibuguey Bay, Sibuyan Sea, and the Sulu Sea yielded most of the catch for herrings, amounting to 1,543 metric tons or 0.4% of the total landings of the commercial fisheries.

Table II
Pelagic Fish Production in Metric Tons by Fishing Grounds (First Ten Highest) in 1971

Fishing Grounds	Roundscads	Sardines	Chub Mackerels	Big-eyed Scads	Anchovies	Herrings
Sulu Sea	125,728	37,974	11,593	5,278	663	427
Visayan Sea	3,677	2,483	701	8,205	220	152
Manila Bay	1,799	374	2,192	316	941	38
Davao Gulf	4,080	148		1,474		
Sibuguey Bay	2,236	893	821	1,093	480	187
Tayabas Bay	1,205		427		270	
Sarangani Bay	946	714	288	292		
Lamon Bay	524					
Batangas Bay	405					56
Sibuyan Sea		101	161			103
Coron Bay					1,364	
Burias Pass	252					
Taytay Bay					826	
Iloilo Strait		218		263		147
Moro Gulf		238	254			
Samar Sea			187		334	
Guimaras Strait				550		182
Tawi-Tawi		152				
Maqueda Bay			206			
Capiz Coast				298		
Illana Bay				103		
Babuyan Channel					439	
Malampaya Sound					253	
Asid Gulf						48
Ragay Gulf						74

3. DEMERSAL RESOURCES (OFFSHORE AND INSHORE)

3.1 Fish Species

The exploitation of the demersal (bottom) resources of the country depends to a large extent on the trawl fishery which in turn depends on 30 families of fishes which include some 98 species. However, only a few species are caught in sufficient commercial abundance. These are the slipmouths (*Leiognathus* spp.); threadfin breems (*Nemipterus* spp.); lizard fishes (*Saurida* spp.); and croakers (*Pseudosciaena* spp. and *Sciaena* spp.). Shrimps and crabs also form a part of the demersal resources.

Some 20 families consisting of 55 species of reef fishes are also considered demersal. The most important are the caesios, porgies, surgeon fishes, snappers and siganids.

3.2 Fishing grounds

The principal trawling areas are Lingayen Gulf, Manila Bay, Visayan Sea, Sibuguey Bay and Palawan waters especially Bacuit Bay, Coron Bay, Taytay Bay and outer Malampaya Sound.

For reef fishing, the principal areas include Stewart

Banks, Scarborough Reef and Apo Reef; also the areas around Fortune, Lubang, Marinduque, Cuyo, Busuanga, Polillo, Ticao, Burias and Masbate Islands.

3.3 Fishing Gear

Presently, the demersal resources of the country are mostly vulnerable to the otter trawl, the muro-ami and the hook and line and occasionally to the gill nets. Some first and second-class fish are also caught by the simple and multiple handlines, fish corrals and deep-water fish ports.

Of these, the otter trawl which was introduced in Manila Bay in 1947, is most important commercially. In 1953, it was observed that the otter trawl fishery in Manila Bay was the most important fishery in the country. From then on there was an increase in the number of trawling vessels operating in Manila Bay as well as in other trawling grounds. Correspondingly, there has been a general over-all decline in the average catch per trip, even with the increase in space and depths of commercial operations.

In 1971, there were 652 units of otter trawls ranging in size from 3 to more than a hundred gross tons. These gave

employment to 10,432 fishermen.

In the early 1930's the Japanese trap net or muroami was introduced in the Philippines. This started the demersal reef fishery. There were 16 Japanese trap-net fishing vessels in operation at the outbreak of World War II. This decreased to 2 units in 1950 due to the use of explosives in the fishing grounds. In 1971 there were registered 37 units which were manned by 962 fishermen.

3.4 Fishing Seasons

As those of the pelagic fisheries, the trawl fishing operations are affected by the monsoon seasons. The trawl fishery is conducted almost throughout the year in the different trawling areas, the operation being shifted from one sheltered coast (productive areas) to another, avoiding the prevailing monsoon.

For reef fishing, the principal operation is conducted during the calm months of December through May.

3.5 Fish Production

In 1971, the otter trawl production was 146,358 metric tons which was 38 per cent of the total commercial catch. This surpasses the production of the purse seine and even that of all the major fishing gear. However, as was mentioned before, it was observed that with an increase in the number of trawlers operating in the various fishing grounds, there was a resulting decrease in the average catch per trip. In 1969 there was a decrease in the total production which may be explained by the decrease in the country's trawlable areas and the more rigorous enforcement of prohibitions on trawling in waters less than 7 fathoms deep.

Thirty-seven units of Japanese nets or *muro-ami* caught 17,894 metric tons of fish which made up 4.6% of the

total commercial fish landing in 1971. The hook and line, on the other hand, landed 7,638 metric tons of fish or 1.9 per cent of the total production of the commercial fishing vessels.

An analysis of the production by kind of the most important demersal species showed that slipmouths predominated in the 1971 catch (Table III). This amounted to 32,579 metric tons or 8.52 per cent of the total commercial fish production. The slipmouths were mostly taken from the Visayan Sea making 4.5% of the total commercial fish landed in the country. The next productive fishing ground was the Sulu Sea; Manila Bay came third.

The nemipterids rank second. Their production in 1971 was 16,655 metric tons which are equivalent to 4.36 per cent of the total production. The amount which was mostly landed from the Sulu Sea was 7,898 metric tons. The Visayan Sea and Manila Bay rank second and third, respectively, in the production of this fish group.

The production of lizard fishes which came third was 12,305 metric tons or 3.22 per cent of the total fish production. Again the Visayan Sea was the most productive, followed by the Sulu Sea and then by Manila Bay.

Fourth in production by kind were the croakers which amounted to 9,404 metric tons or 2.46 per cent in 1971. The Visayan Sea, the Sulu Sea and Manila Bay were the first three productive fishing grounds for these fishes.

Of the invertebrates, shrimps constituted 3.32 per cent of the total fish production. This amounted to 12,702 metric tons. The Sulu Sea was the most productive, followed by the Visayan Sea and then by Manila Bay. The crabs were mostly caught from the Visayan Sea and Manila Bay. Those caught by the otter trawl amounted to 1,737 metric tons in 1971.

Table III

Demersal Fish Production in Metric Tons by Fishing Grounds (First Ten Highest) in 1971

Fishing Grounds	Slipmouth	Nemipterid	Lizard Fish	Croaker	Shrimp	Crab
Visayan Sea	17,480	3,472	7,697	6,018	6,017	1,134
Sulu Sea	7,162	7,898	1,861	1,258	3,671	2
Manila Bay	2,751	2,363	687	366	1,325	22
Sibuguey Bay	272	847	17	6	84	2
Lingayen Gulf	191	57	92	30	57	1
Sibuyan Sea	141	4	26	9	11	
Panay Gulf	142	44	53	99		
Batangas Bay	67	48				
Davao Gulf	36	11	2		4	0.2
Tawi-Tawi Bay	20					
Sarangani Bay	10	4				
Taytay Bay	2					
Cuyo Pass	0.3					

3. OTHER RESOURCES INCLUDING AQUACULTURE AND MINOR SEA PRODUCTS

3.1 Aquaculture

Aquaculture or fish culture in the Philippines included cultivation of fish both in the brackishwater areas and inland bodies of water. It is quite well developed and extensive on the brackishwater areas while in the inland areas it is just beginning.

There are about 168,400 hectares of developed fishponds, 365,318 hectares of undeveloped salt and brackish water mangrove swamps and 126,248 hectares of potential freshwater fishponds available for development and about 150,000 hectares of inland bodies of water as lakes and dams.

In 1971, 10% of the total fish production of the country or roughly, 100,000 metric tons of the total 1,000,000 metric tons produced was from fishponds.

Fishes harvested from lakes, rivers and other inland bodies of water most probably comprised a small percentage of the total 543,000 metric tons of fish produced by the municipal and sustenance fishing.

The average annual production of the developed fishponds is about one-half ton per hectare which is low five compared to other countries where production is about five times more. This represents a total investment of about P340,000,000 (US \$2,278,000,000).

3.1.1 Brackishwater ponds

About 150,000 hectares of swamp lands have been developed primarily for the culture of milkfish or bangos (*Chanos chanos*). The techniques of bangos culture are based on the fact that the bangos or *Chanos chanos* spawns in the sea and the fry drift with the current to coastal areas. The fry are caught by professional collectors and sold to pond operators who grow them to the fingerling stage. Table IV shows the number of bangos fry which were gathered for the year 1971 from the different regions in the country and which were sold to fishpond operators for stocking purposes. The stocking rate varies widely from 2,000 to 12,000 per hectare of pond.

3.1.2 Freshwater ponds

Although not yet common in the Philippines, yet attempts have already been made on the aquaculture of commercially important species like bangos (*Chanos chanos*), hito (*Clarias* sp.) and the common and Asiatic carps so that areas of developed fishponds may be expended. The fish seeds of the common carp can be produced by local hatcheries but Asiatic carps require a special technique, namely the injection of pituitary hormone, to induce them to spawn.

Even with the very few data on the freshwater fisheries that are available, it is estimated that freshwater fishponds can yield 300–500 kilograms on the average.

The use of fish pens which is the most recent innovation in aquaculture was started commercially in 1972. This is a cheap and feasible method of culturing fish especially bangos, carps and tilapia in our freshwater areas. This makes use of the principle that fishes utilize the available food organising in an enclosed area of any inland body of water as lakes and dams.

This method of culture is being done in Laguna de Bay, Sampaloc Lake, San Pablo, Taal Lake in Batangas and Lake Bato in Camarines Sur. Lake Lanao in Lanao and Lake Buluan in Cotabato are also being considered for fish pen operation. In Laguna de Bay there are 252 fish pen units ranging from 1/5 of a hectare to 24 hectares. As much as 8–12 metric tons can be harvested from one hectare per season.

3.2 Minor Sea Products

The territorial marine waters of the Philippines abound in aquatic life other than fish. These are mollusks, crustaceans, echinoderms, reptiles, sponges, corals and seaweeds.

3.2.1 Mollusks

Of all the countries in the Indo-Pacific Region, the Philippines produce the greatest variety of sea shells.

The mother of pearl oysters include two important species, the gold lip (*Pinctada maxima*) and the black lip

(*P. margaritifera*) shells. Both species are found in many parts of the country but especially around Basilan and the Sulu Archipelago, Illana Bay, Palawan waters, the Visayan Sea especially around Bantayan Island and the waters around Natanes Group. Besides being used for the culture of pearl, a valuable export product, the pearl oyster shells are also used in the manufacture of pearl buttons and shellcrafts. *Pinctada martensii* is found in commercial quantities in Davao Gulf for the culture of Japanese pearls.

The smooth top shells (*Trochus niloticus*), the rough top shells (*T. maximus*) and the turbo shells (*Turbo marmoratus*) are those that constitute the so-called button shells. The trochas are found in littoral shallow reefs around the Batanes Islands, Pangasinan, Bical provinces, Palawan, Eastern Samar, Masbate and Eastern Davao Gulf. The turbo shells abound around the islands of Masbate, Cebu, Tawitawi and Sitankai, the coasts of Negros and northern Palawan. These button shells are made into buttons; their meat is used for food.

Twelve species of oysters are commonly found in Philippine waters. But three are commercially cultivated in bays, coves and estuaries in Luzon, Visayas and Mindanao. These are *Ostrea malabonensis* (*Kukong kabaya*), *O. iredalei* (*talabang chinelas*) and *O. cuculata* (*pulid-pulid*). Oyster meat is a favorite culinary item among Filipinos while the shells are used for clutch, lime, paints and poultry grit.

The *tahong* (*Mytilus smaragdinus*) is also widely distributed throughout the Philippines in the littoral zones, in shallow coves, bays and mouths of estuaries where the water is strictly brackish and not subject to heavy silting. It is cultivable. *Mytilus* farms have been established in Manila Bay along the coast of Bacoor, Cavite. The meat of this mussel has a flavor that is comparable to may edible mollusks.

The window pane shell which is called the *Placuna placenta* is the main source of shells for window panes, screens and various kinds of shellcrafts both in the Philippines and the Asiatic mainland. It is widely distributed at the eastern part of Manila Bay and the waters bordering the provinces of Pangasinan, Bohol, Negros, Capiz, Iloilo, Masbate and Mindanao. It can be cultivated like the oysters and green mussels especially in shallow brackish waters with muddy bottom. Its meat can also be used for food.

Marine decorative shells like the papal mitra, imperial harp, tapestry, courtire volute, imperial volute and scallops are fairly well distributed throughout the country's coastal sea reefs and deeps. Rare shells can be gathered from Samar, Marinduque, Mindoro, Masbate, Hundred Islands in Pangasinan, Catanduanes, Quezon, Palawan, Antique and the Sulu Archipelago. The *Conus gloria maris* which is the most beautiful and famous is very rare and costly.

Other edible shells like the clams, saltwater mussels, whelks and the chambered nautilus are found along the shores of Lubang, Mindoro and the provinces bordering Manila Bay, Lingayen Gulf and Babuyan Channel.

The squids (*Loligo* spp.), cuttle fish (*Sepia* spp.) and

octopuses (*Octopus* spp.) are pelagic in fishing banks, bays, coves, open seas and reefy areas especially around Mindanao, Bantayan Island, Manila Bay, Lingayen Gulf and the Bicol region. Those species suitable for marine culture are used for food and fish bait.

3.2.2 Crustaceans

The fresh shrimps and lobsters found in Manila markets are mostly of the three genera, namely: *Palaemon*, *Penaeus* and *Palinurus*. The first genus includes both brackish and freshwater shrimps. The second genus refers to marine and brackishwater forms while the third includes only the marine spiny lobster or banagan. These come from Manila Bay, Lingayen and Ragay Gulfs and from fishponds and fish corrals being operated in various parts of the Philippines. They are usually utilized as food but the sugpo (*Penaeus monodon*) has become popular because supplying sugpo fry to fishpond operators is now a distinct and lucrative industry in many places in the Philippines.

The crabs are mostly marine and brackishwater forms. The most popular edible species are *Neptunus pelagicus* (*alimasag*) and *Scylla serrata* (*alimango*). They are abundant in almost all fishing banks like Manila Bay, Panay Gulf, Zamboanga waters especially Sibuguey Bay, Visayan Sea and Samar Sea.

3.2.3 Echinoderms

Among this group of animals, the holothurians, known as trepang or balatan or beche-de-mer are the most important and popular. These sea cucumbers are gathered from the deep seas and reefs of the Sulu Archipelago, Mindanao, the Bicol provinces, Leyte, Palawan Batangas, Lingayen and Quezon. Cured trepang is used in Chinese cuisine in preparing savory soups and meat stews.

Other echinoderms like starfishes and sea urchins are also found in reefs. They are gathered and dried for decorative purposes. The gonads of sea urchins are cooked and eaten like fish roe.

3.2.4 Reptiles

Sea snakes of the genus *Lacticauda* are common in harbors, bays, rock shelves and reefs. *Hydrophis inornatus* is common in Manila Bay and other bays of the Philippines. Tanned snake skins are manufactured into bags, belts and shoes for local use and export.

The marine turtles that are common in warm waters of the Philippines are the hawksbill (*Eretmochelys imbricata*), the green turtle (*Chelonia mydas* and *C. japonica*) and the loggerhead (*Thalassochelys caretta*). The tortoise shell of commerce is supplied by the first species; meat and eggs by the second species and turtle oil of commerce in addition to eggs and meat by the third one. The Turtle Islands near Borneo are the known turtle breeding grounds.

3.2.5 Sponges

The commercial species of sponges that occur in Philippine water beds are the sheep wool sponge, elephant ear simocca sponge, rock sponge, reef sponge, grass sponge and silk sponge. These are gathered in the shallow waters of Sitankai reefs, Tawi-tawi reefs. Seasi and Sacol Island in the Sulu Archipelago and in the sponge beds of Zamboanga, Basilan and Cebu. Sponges are processed and used in

industries for absorbent materials.

3.2.6 Corals

The corals due to their graceful forms and soft colorations serve as the chief attraction of tropical and subtropical "submarine gardens". The red or horny corals (*Corallium* spp.) are precious and are found in Davao Gulf and in the continental shelf northeast of the Babuyan Islands. The black corals (*Anthipathes* sp.) are found in shallower waters around the Sulu Archipelago, around Mindanao, Palawan and the western coast of Luzon. They are made into jewelry such as bar pins, bracelets and earrings.

3.2.7 Seaweeds

The thallophytes or seaweeds (green, brown and red algae) play an important part in the economy of both orientals and occidentals. In the Philippines, these abound in the shallow waters around Batanes Islands, Babuyan Islands, Luzon, Lubang Islands, Palawan, Visayan Islands, Northern Mindanao and the Sulu Archipelago.

Eucheuma sp. (*ruprupuuc* or *guso*) is a red alga which is the most important commercial seaweed in the country. This alga grows on coral reefs and in the rocky and sandy bottom of marine inter-tidal or subtidal zones where the water is very salty, clear and fast moving. In the Visayas and Mindanao areas, it is eaten raw as salad. From it is extracted "carrangeenin", a valuable substance used in products that need gelling, suspending, thickening or water holding properties like ice cream, peanut butter, paints, cosmetics, textile rubber products, etc. This alga grows in great abundance in the Sulu Archipelago, Zamboanga, Palawan, Cebu, Bohol, Samar, Surigao and Polillo. It may also be found in Pangasinan, Mindoro, Negros, Panay, Batangas, Masbate, Leyte, etc.

Gracilaris conferviodes (*gulaman dagat*) is the species most extensively found in Manila Bay especially from November to May. Other sources of *Gracilaria* are Zamboanga, Sulu and Cagayan. These seaweeds are the main source of agar-agar or gulaman which is used in some bakery and dairy products, candy, jelly, canned foods and other items; its most important service is as a bacteriological culture medium. *Gracilaria* is also used as supplemental food for the bangos. Japan, quite recently, has become our biggest importer of this seaweed.

Gelidium sp. or agar weed abounds in the inter-tidal and subtidal littoral zones. It is one of the sources of high quality agar and is very much in demand in Japan.

Hypnea, a red seaweed, is a source of commercial agar. It is also being utilized directly as food in many parts of the country like Manila Bay area, Mindoro, Zamboanga and Cagayan (Santa Ana).

Sargassum — This is a brown alga and is most abundant in the coral reef areas like the Hundred Islands in Pangasinan, the Palswan area, Mindoro, Cebu and Batangas. It was found to have a high content of alginic acid and may be used in the production of commercial alginate chemicals. It may be also be utilized as fertilizer.

Digenea simplex (*bodo-bodo*) — This seaweed is found in the northern coast of Luzon and is an efficient vermifuge. It is also eaten fresh or dried by some people.

4. ECONOMIC AND SOCIAL ASPECTS OF THE RESOURCES

4.1 Fish Marketing

In the Philippines fish marketing is entirely carried out by private enterprises without any government intervention, in market sheds in bigger coastal cities and towns and in most places just on the beach. The wholesale of fish takes place at night during the very early morning hours so that fish can be distributed to the retail markets before the temperature goes too high. The sale of fish is mostly done by women who sell them either by secret bidding (whispering) or by open bidding.

4.1.1 Fish Handling

In the Manila area, the most important landing place for fish is the Navotas Fish Landing where more than 50 per cent of the total catch from the commercial fishing is landed. Here, the market itself consists of a long shed on the beach. The fish are placed on the bare sand in various containers mostly tubs (bañeras) containing 35 to 40 kg. of fish and small boxes made of bamboo strips containing about 6 kg. of small trawl fish and shrimps.

In many instances, the brokers have constructed an elevated concrete floor from the roadside to the waterfront where fish are chuted down from the amphibians to the ground and carried by hand further up in the market.

The then Philippine Fisheries Commission (now Bureau of Fisheries) had started constructing a 4,000 sq.m. market hall with 3 m. x 20 m. stalls on the 2.5 hectare site in Navotas. Although it is not yet complete, it has somehow facilitated the marketing process with the expansion of the deep-sea fishing fleet.

The other wholesale fish market is at the Divisoria central market in Manila. The wholesale of fish takes place in the open in the street and sidewalks alongside the retail market. The fish is brought in by trucks from other landing places in the south as well as by railway from the Bicol area. Fish especially milkfish brought in by inter-island vessels to Manila are also sold here. The sale procedure is similar to that in Navotas although the fish are sold by weight (kilos).

In the provinces, the wholesale fish markets are in a better condition than those in the Manila area. Most of them have at least concrete flooring and better sanitary conditions. However, they are hampered very much by lack of ice which, if available, is priced very high, almost three times as high as in Manila.

4.1.2 Transport and Distribution.

Transport of fish by land is carried out by ordinary trucks and jeepneys and by railroad and public buses on a small scale. Sea transport is almost always carried out by private vessels. Only small quantities are transported by inter-island vessels. Air transport is also carried out either by the regular passenger flights or at times by chartered cargo planes.

When fish are landed at some landing points, these are transported by trucks to the Manila markets. Such trucks are of the ordinary openbodied type without insulation or any form of refrigeration. If the fish are packed with ice and the temperature in the fish is about 8° to 10°, it is obvious that the flow of warm air over the fish raises the temperature and accelerates the melting of the ice. The same type of truck is used for distributing fish from the wholesale markets in the city and suburbs.

The fish carriers are actually ordinary fishing vessels which can be used not only for transporting fish but also for fishing. These are provided with insulated holds for ice and fish.

4.1.3 Ice Plants and Cold Storages

In Manila as a whole, the ice plants can produce about 1300 tons of ice a day, of which about 30 per cent is available to the fishing industry and can therefore meet its demands. However, during the peak season of galonggong or roundscads which coincides with the hot season, the vessels sometimes wait for more than a week getting ice because the production of ice is hampered to some degree by water shortage. Despite all these the ice operators are doing their best to increase production by expanding their plants.

In the provinces, ice production is intended more for consumption by hotels and restaurants and other purposes. Several plants produce just enough ice for the normal daily sale and during the summer season do not produce a stock of ice to meet the demand. Thus, there is almost a permanent shortage of ice for the fishing industry.

The then Fisheries Commission started putting up small units of flake ice plants at various places wholly to supply ice to the fishing industry in remote areas where ice had not been available. At present there are 14 ice plants that have been completed and are operating at strategic points all over the country.

The Bato-Bato ice plant in Tawi-Tawi, Sulu now enables the Sulu fishermen to deposit their catch at the

Table IV

Bongos Fry Production for 1971

Sources	April	May	June	July	August	September	Total
Regional Office No. I		5,955,000	33,015,000	7,115,500			46,085,500
Regional Office No. II							No report
Regional Office No. III		628,000	325,000	200,944,800			201,897,800
Regional Office No. IV	100,000	1,803,200	885,000	23,500	520,000	2,515,000	5,846,700
Regional Office No. V				34,702,400			34,702,400
Regional Office No. VI			330,000	17,680,000			18,010,000
Regional Office No. VII							No report
Regional Office No. VIII	44,000	237,000	130,000				411,600
Grand total	144,000	38,623,800	234,685,000	260,466,200	520,000	2,515,000	306,954,000

ice plant to be accumulated to bigger commercial quantity and await better price or to be sold to some of the fishing vessels and carriers from Luzon, the Visayas or Mindanao, plying in that area. Besides, commercial fishing boats which used to travel far to go fishing and return for ice supplies would now be able to fish the whole year round in the Sulu seas.

The new ice plant in Enrique Magalona, Negros Occidental is well situated to serve the storage of dried and fresh fish for local consumption and transshipment of bangos to Manila through Bacolod.

These 14 ice plants have a combined ice-making capacity of 168 metric tons per day and total fish storage capacity for 1,145 tons per day.

The then National Economic Council (now National Economic Development Authority), following President Marcos' directive, approved an allocation of 14 additional ice plants and cold storages to be acquired through Japanese reparations for the Bureau of Fisheries. These additional cold storage plants are expected to increase the incremental production goal of the Bureau from 90,000 metric tons to 110,000 metric tons of fish annually.

4.2 Fisheries Cooperatives

The Bureau of Fisheries has started organizing fisheries cooperatives in strategic areas throughout the country. Of the 16 fisheries cooperatives that were targetted in 14 provinces of the Philippines by the Bureau, four cooperatives have been formed. These are the Cavite City Small Fishermen's Cooperative and Marketing Association and the Naic Small Fishermen's Cooperative and Marketing Association in Cavite, the Bocawe Fisheries Cooperative Association in Bulacan and the San Jose Fishermen's Cooperative and Marketing Association in Mindoro Occidental.

Other fisheries cooperatives now under organization are those in Bacoor, Cavite; Bulacan, Bulacan; and Sexmoan, Pampanga.

The Bureau of Fisheries together with the ACA, APC, CBRB and NFAC is helping fishermen in various towns and barrios form cooperatives.

The government has also made available to the fishery cooperatives low-interest loans to enable small fishermen to buy better fishing bancas, motor engines and nets. Fishermen are considered small-time fishers if their boats do not weigh more than tons. The combined catch of this group in 1971 accounted for almost one-half (46 per cent) of the total national harvest.

A fisherman may borrow as much as P5,000* without collateral but he must be a member of a Fishery Cooperative and his project certified as viable by government technicians. Loans are payable in three years.

There was formed a fish marketing action committee with members from six government agencies and headed by the chief of the Bureau of Fisheries' Market Assistance Section in order to speed up the forming of cooperatives and the processing of loan applications.

The committee intends to organize and help finance fishery cooperatives in marine barrios especially in Luzon Island.

* U.S. \$1.00 - P6.70

4.3 Fisheries Statistics

In the formulation of fishery development, management and conservation programs, statistics on fisheries is a basic requirement.

In May 1966, a systematic collection of fishery statistics was launched under the guidance of Mr. Tsugiharuru Shimura, former FAO Fisheries Statistician so as to cover all phases of the inland and marine fishery industries.

Mr. Shimura initiated a sampling survey of fish landed in Navotas, independent of the fish catch reports submitted to the Fisheries Commission by fishing boat operators and encargadores.

A statistical survey team composed of four members has been working in shifts since July 1966 at the Navotas fish landing counting the number of amphibian boats (U.S. Surplus DUKW) and smaller boats ferrying fish from fishing boats anchored a short distance from the shore. One amphibian boat carries a regular load of 80 baneras, each banera weighs 35 to 40 kilos.

A sampling survey of marine sustenance or municipal fisheries was another innovation started by Mr. Shimura. This involved an enumeration of marine barrios, fishing families, fishing boats, fish corals in operation, fishermen engaged in bangos fry gathering and families engaged in oyster raising.

Surveyed in Northern, Central and Southern Luzon were : Ilocos Norte, Ilocos Sur, La Union, Pangasinan, Zambales, Cagayan, Bataan, Pampanga, Bulacan, Rizal, Cavite, Batangas, Quezon, Marinduque and parts of Palawan and Masbate. Other places surveyed were those of the other fisheries regions like the Bicol Peninsula, the Eastern and Western Visayas, Zamboanga, Davao and Occidental and Oriental Misamis putting the survey coverage at 82.2 per cent.

With about 6,000 marine barrios in the Philippines, it is estimated that in 1970 the marine municipal fisheries involved about 574,330 small fishermen equipped with about 271,292 fishing bancas of which only about 20 per cent are motorized.

The latest issue of the Fisheries Statistics of the Philippines (1971) came off the press recently. The outstanding statistical data that were culled from this publication follow:

Fish produced for 1971 by sources of production showed that commercial fishing vessels produced 382,276 metric tons valued at P879,235. Fishponds produced 97,915 metric tons worth P328,016 while municipal and sustenance fishing amounted to 542,904 metric tons valued at P1,406,121. The total production, therefore, was 1,023,095 metric tons with a value of P2,613,372.

The 1971 fish production is about 34,211 metric tons more than the 1970 production or showed an increase of only 3.5 per cent over the previous year. Perusal of the 1971 publication shows that fish production has steadily increased through the last 5 years (1967-1971) although not remarkably. However, despite this, the increases are not sufficient to cope with the population increase of the country.

In 1971 the per capita fish consumption of the country was 28.35 kilograms while the per capita fish allowance

per year was 36.5 kilograms. It can be seen that Filipinos do not have enough fish as the per capita consumption is lower than the fish requirement established by the Food and Nutrition Research Center in 1969. The same relationship between per capita consumption and fish requirement can be observed through the last five years (1967-71).

To fill in the pressing consumption deficiency for fish the country imported 68,883 metric tons of fish and fish products in 1971 with a total value of P142,846,921. The average annual importation of fish and fish products, from 1967 to 1971 was P101,458,794. The 1971 fish importation is about 34,728 metric tons more than the 1970 importation. This is an increase of 32.1 per cent over the previous year. This dependence on fish importation to augment the much-needed protein in our diet is a virtual subsidy for foreign fishing operations and fishermen.

On the other hand, as opposed to the huge imports, our exports of fish and fishery products in general have been negligible but there is also an increase in quantity and value from 1967 to 1971 (except 1968). In 1971, the country exported 7,300 metric tons of marine fish and fishery products with a value of P40,052,528. These exports surpassed all records since 1948. In 1970 the total

fishery exports reached about P18 million. The percentage increase in 1971 over the 1970 figures reached 55 per cent.

The top money makers for the 1971 exports were the frozen shrimps which reached a total of P20.4 million for 1,454 metric tons exported. Frozen tuna ranked second earning P8.2 million for 2,293 metric tons and tiny marine fishes claimed the third place with total earnings of P1.6 million for 184 metric tons (See Table V).

In 1971 there were 2,180 fishing vessels registered with an aggregate gross registered tonnage of 90,550 metric tons as compared to the registered fishing vessels of 2,361 with a total gross tonnage of 81,268 metric tons in 1967.

The 1971 statistical publication contains other data on fisheries.

In June 1971, Dr. Todashi Yamamoto, FAO Regional Fisheries Statistician (Bangkok), conferred with the then Fisheries Commissioner and other ranking officials. His purpose was to follow up the recommendations made by Mr. Shimura regarding improvements of fisheries statistical activities so as to accelerate the pace of their development. Dr. Yamamoto initiated the improvements in fisheries statistical work especially in the gathering and processing of data secured during the 1971 fisheries census.

Table V
Value of Fishery Products Exports in Pesos
(1969 - 1973)

Note: Listing includes only the 15 highest values for each year.

1 Philippine Peso = 0.148 U.S. Dollar

Product	1969	1970	1971	1972	1973 (January to March)
1. Frozen Shrimp	2,290,832.20	7,828,444.84	20,431,408.29	34,186,368.89	9,620,999.67
2. Frozen Tuna	1,286,651.47	2,519,782.42	8,205,261.94	18,358,301.03	2,652,889.06
3. Shellcraft Articles	1,086,205.94	394,529.50	702,339.79	801,693.44	88,085.70
4. MOP Shells	551,699.24	982,555.88	834,569.13	742,171.48	321,960.80
5. Seaweeds	436,609.98	488,730.78	533,977.00	1,633,586.25	563,519.00
6. Live Tiny Marine Fish	428,695.36	1,000,242.77	1,693,365.28	3,377,780.64	1,710,026.90
7. Salted Fish	364,395.19	446,558.00	792,267.83	1,421,804.38	248,496.71
8. Finished Buttons	264,802.60	323,691.10	169,559.80		
9. Sponges	194,213.60	160,620.00			99,198.00
10. Kapis Shells	188,373.20	98,332.35			
11. Fish Sauce	107,626.96	171,570.91	381,576.66	458,508.12	219,801.80
12. Frozen Bangos	105,780.10	387,866.06	1,109,323.28	274,878.00	
13. Ornamental Shells	93,320.68	145,221.56	177,673.80		125,413.00
14. Reptile Skins	65,026.81		381,150.40	362,493.68	525,228.07
15. Frozen Cuttlefish	48,241.53				
16. Button Blanks		255,142.00			
17. Frozen Fish		150,644.20	421,240.72	1,929,802.15	1,304,898.51
18. Frozen Lobster			336,820.54	2,190,291.19	373,040.28
19. Dried Fish			169,227.20	247,726.85	
20. Eel Fry				443,814.70	
21. Frozen Shark				357,470.00	
22. Dried Shrimps					171,768.87
23. Trocas Shells					63,340.00

5. IDENTIFICATION OF PROBLEMS AND POSSIBLE ACTIONS

5.1 Problems

The development of marine fisheries during the last decade has been spectacular, especially with the expansion

of the purse seinebasnigan fisheries in the early 1960's. All of a sudden the pelagic fisheries appeared to be over-capitalized. However, production is still low and the yield is declining. The resulting reduction in catch per unit of effort may be attributed to the fact that only the country's coastal and inshore waters are being exploited, and over

exploited at that. Hence, there is always a yearly deficiency in our fish production although the country's territorial marine waters are six times its land area. In 1971 the Philippines occupied the 14th place among the top fish-producing countries in the world and the fourth leading fishing nation in Asia. This indeed is paradoxical.

In order to cope, therefore, with the fish consumption needs of the people, our Government has to depend on foreign markets for the much-needed supply of fish. Philippine imports in 1971 amounted to U.S. \$20,406,703.

Another reason for our low fish production is the lack of information on factors controlling distribution, abundance and availability of fisheries resources in spite of the great studies undertaken in biological researches. This may be partly explained by the fact that there is a difficulty in studying the age groups of our fishes. For example, the adult breeding stock in the case of *Decapterus* is not fished to any extent.

This problem is aggravated by the absence of complete catch and effort statistics that can be used as a basis for estimating future potentialities of the pelagic fisheries.

There is also a lack of knowledge among fisherman to operate big fishing vessels in the open seas. Because of this, there exists that timidity in most fishermen with the mistaken belief that to engage in deepsea fishing is risky. Furthermore, the fishing methods used are still antiquated because of the high cost of modern fishing vessels and gear.

Over and above all these problems is the lack of capital which is very necessary if the facilities of deepsea fishing are to be provided for.

Among the fishermen engaged in the demersal fisheries, disputes and differences between different types of fishing operators constitute the predominating problem. These disputes and differences arise from encroachment of fishing areas, unequal gear efficiencies and the advantages of mechanization and craft size.

Then, as in pelagic fishing, there is the difficulty in making an estimate of the potential yield of the fisheries. This is so, because almost everywhere, fishing operations result in a mixed catch. In temperate and arctic fisheries, usually one species dominates a given fishery at a given time and place so that the fishery can be managed as to maximize the catch of this particular species of fish. In tropical waters, this is often not the case.

Along the line of freshwater aquaculture, problems also do exist. First and foremost is the insufficiency of biological information that may support the applied studies being done to increase fish production. Again, too, there is the lack of scientists in fish biology and fish breeding. Good research facilities are likewise limited. Finally, financial support from the government of basic studies in fish biology and fish breeding is inadequate.

In the case of brackishwater aquaculture, similar problems as the above exist. These are limited facilities in research equipment and research stations in estuarine areas, lack of technical manpower, and limited funding support.

On mariculture, very little work has been done in the

Philippines. Although there are studies in growing oysters (*Crassostrea*), *tahong* (*Mytilus*), gamet (*Porphyr*a) and some marine algae (*Eucheuma*), no comprehensive economic or biological study has been done on any marine resource. More studies on the successful practices of mariculture are therefore needed now for there is a great demand for knowledge on all marine fauna and flora of the sea, as a source of food and for export. Hand in hand with this need is the lack of expertise and skilled manpower who can undertake research and the subsequent application and/or exploitation as well as of venture capital.

Studies on crustacean culture are incidental cultures of these organisms with *baños* in brackishwater ponds. In spite of a lot of publicity on successes in sugpo breeding and sugpo culture, technical papers on these are still scanty.

The statistics of our country and those of other Southeast Asian countries are still very inadequate as a basis for estimating future potentialities of the various fisheries. This can be explained by the lack of necessary manpower and funds to undertake exhaustive and indepth data collection and research and by the duplication of effort. There is also the lack of updated technical information.

5.2 Government Action and Possible Solutions

For pelagic fishery to become successful in this country, the most important pre-requisite that should be satisfied is capital. The Government should provide funds so that all projects that are proposed by the private sector may be carried out adequately for the development of the fishery. Additional sources of funds should also be sought for. These are done by making representations with world banking agencies which are especially interested in the development of agriculture and fisheries. The private sector, especially the moneyed group who are engaged in commercial fishing, is also being encouraged to invest in the pelagic fisheries so that the fishing sites in the open seas beyond the three-mile limit may be properly harnessed. This is possible through the integration of the activities of the Bureau of Fisheries with the private sector thru the recently created Fishing Industry Development Council.

With the limited funds available, the Bureau of Fisheries should undertake the research program of studies which normally cannot be undertaken by the private sector. But as much as possible the private sector must be involved by using its facilities as fishing vessels and making available to the government its catch data while undertaking fishing activities in both pelagic and demersal fishing grounds. At the same time technical assistance should be continually extended by the Bureau on the improvement of fishing gear, fishing operations and the acquisition of new fishing outfits.

The World Bank through the Development Bank of the Philippines would soon give loans of more than 100

million pesos for the fishpond and deepsea fishing industries.

Furthermore, it is probably high time now that the Government adopt an insurance scheme for the fishing industry whereby disaster and losses to fishermen could be guaranteed and adequately compensated.

With the Government's policy to increase fish production is the program to expand areas of development of fishponds. To do this, the Bureau will deploy more extension workers to the provinces where they will guide new fishpond operators on the proper construction and layout of fishponds and improvement of production techniques. It also intends to lease some 8,800 hectares of swamp lands yearly to the private sector for development into fishponds.

At the same time, more knowledge on the commercially important freshwater and brackishwater fishes especially their life history, spawning, population, ecology and on other commercially important invertebrates are to be secured in accordance with set priorities for the proper management and conservation of our lakes, rivers and estuaries.

Funds given to fish biology and breeding studies should depend on the priority areas of research. These studies should be through team efforts or through agencies with facilities for this purpose. In the case of estuarine biology and ecology studies, the research activities need expensive equipment. Because of this, the funding must be shared by the different agencies involved in the research.

The SEAFDEC is establishing through the Bureau of Fisheries and the Mindanao State University (MSU), an Inland Fisheries Center, a regional center especially in shrimp culture. The MSU also has a shrimp hatchery center in Naawan, Misamis Oriental, Mindanao. Both these projects are well-funded, ranging into millions of pesos.

The University of the Philippines has just started an NSDB/AID assisted Inland Fisheries Project at Leganes for brackishwater fish culture and the Central Luzon State University for freshwater fish culture with multi-million pesos funding.

Scientific personnel contributions may be tapped from different agencies, if necessary. To alleviate the lack of technical manpower, scholarships must be secured to send abroad for training or graduate studies deserving Filipinos who are inclined to these disciplines including mariculture.

The Fishermen's Training Center which will train deck officers and master fishermen in marine fisheries through

the Bureau of Fisheries and FAO, has been approved for implementation by the United Nations Development Program.

In connection with marketing, the National Food and Agriculture Council (NFAC) through the Fish Marketing Action committee for 1972-75 has proposed to complete the Navotas fishing harbor project this year. Feasibility studies on the proposed establishment of a Fish Port in Lucena, Quezon as well as in other areas like Bacolod; Iloilo; Sta. Ana, Cagayan; Poro Pt., La Union; Legaspi, Albay; Dumaguete City; Davao; and Zamboanga have been considered. Assessments of transport used in the distribution of fish from Navotas-Malabon-Divisoria launching points to evolve improvements were scheduled as well as for Damortis, La Union; Lucena City; Mercedes, Camarines Norte; Iloilo City; Bacolod City; Cadiz, Occidental Negros; and Zamboanga City.

It may be recommended that research on the improvement of marketing infrastructure and transport facilities should be conducted with the end in view of facilitating the flow of fish distribution, reducing market costs and excessive profit margins. It is also necessary to bring to barrio level the knowledge that there is on fish handling and preservation including the use of new techniques to produce improved fishery products for both the domestic and export markets.

Aside from tapping the private sector and the agencies interested in fisheries development for assistance, the Central Bank is extending credit to municipal fishermen in kind like marine engines, nets and other fishing paraphernalia.

Because the number of fishing barrios is great, more feasibility studies are being undertaken to determine which barrios can qualify in this credit scheme. This financial assistance would also be extended to the fish processing and handling sector of the industry and feasibility studies would also include this sector.

Lastly, for the improvement of the statistics on fisheries, collection, updating, consolidation and interpretation of fisheries data and information are being made more systematic. Past studies of major fisheries should be reviewed and updated to cope with the recent innovations and changes. Studies on new and/or little-known fisheries and fishing industries to complement existing fisheries and industries should be initiated. Through these, all fisheries data and information can serve as a basis for the scientific analyses of our fisheries and for the formulation of policies regarding their proper development and management and their wise conservation.

SEAFDEC/SCS, 73: S-9

**The country report of the Republic of Singapore
Status of Fisheries Development in Singapore**
by
**Primary Production Department
Republic of Singapore**

With increasing conflict in the utilisation of limited land resources for industrialization, urbanisation, water

conservation, recreation and farming, Singapore, an island of 585 sq. km. and approximately 2.1 million population,

must look to the sea for its future food supply. Infrastructures have been established during the past few years aiming at offshore fisheries development in the Republic while plans have been initiated for the maximum utilisation of limited inland and coastal waters for intensive aquaculture.

The total local production in 1972 was 15,662 tons representing about 25% of total fish landings in Singapore. Of the 45,295 tons of fresh fish imported 80% came from West Malaysia while exports amounted to 3,967 tons.

The landings from offshore waters made up about 72.9% of the local production of fish in 1972. 33.4% of the landings was caught by otter trawling and 29.4% by trolling. Longlining landed 9.7% while all other methods together brought in only 0.4%. Of the 254 inboard powered boats registered for fishing purposes, 117 were used in otter trawling, 77 in trolling and 10 in longlining. There were 1,602 fishermen licensed for working in inboard powered boats.

Singapore realises the importance of offshore fisheries and is nurturing its development. There are five fish processing plants operating in Singapore, three are under construction and six sites have been offered for similar development. At the main fishing port, the total cold storage capacity available is about 3,000 tons. This main fishing port, located at Jurong, provided landing facilities for 756 local and foreign vessels last year to discharge 13,227 tons. The Primary Production Department also provides facilities for inspection of processing plants and issues health certificates for fish products.

In subscribing to the policy of regional cooperation Singapore is providing building facilities, scientific and

service staff and one-third of the operating cost to the Marine Fisheries Research Department, one of the departments of the Southeast Asian Fisheries Development Center (SEAFDEC) to conduct offshore fisheries research with the aim of contributing to fisheries development in the region. At the Fisheries Training Centre, a joint project with UNDP, training in offshore fishing, navigation and engineering know-how is carried out.

Local production from inshore fisheries was 21.6% of the total landings in 1972. Apart from other minor gears, the production was mainly from palisade traps. However, during the last decade, the production has dropped by almost 40%.

Singapore has largely relied on traditional methods of fish cultivation. However, emphasis has recently been laid on more scientific approaches. The re-orientation will directly lead to more intensive methods of farming highly priced fish for maximum utilisation of land and water resources, and will intimately involve socio-economic factors. Some of the projects have resulted in the successful mass production of marble goby fingerlings (*Oxyeleotris marmorata*) and juveniles of *Macrobrachium resenbergtii*. Experiments on the intensive culture of grouper (*Epinephelus tauvina*) in floating cage-nets and the breeding of *Siganus oramin* and marine prawns (*Penaeus indicus* and *Matapenaeus ensis*) have been encouraging.

Ornamental fish and aquarium plants are cultivated for local and foreign markets. In 1972, the export value for these two items totalled more than S\$10 million. The Freshwater Fisheries Laboratory has continued to provide technical assistance to hobbyists, breeders and exporters.

SEAFDEC/SCS. 73:S-20

The country report of the Kingdom of Thailand

by

Department of Fisheries

Ministry of Agriculture and Cooperatives

Bangkok, Thailand

Fishery Administration

The development of the Thai fisheries during the past few years has resulted in a spectacular increase of total landing of fish; particularly marine fish landing (Table 1). According to recent fisheries statistics, the total catches of both marine and freshwater fish increased from 1.44 million metric ton in 1970 to 1.58 million metric ton in 1971. This remarkable increase of marine fish landing is mostly due to the rapid development of commercial trawl recently, and of which resulted a drastic decline in the abundance of demersal fisheries resources in the Gulf of Thailand (Table II). The Ministry of Agriculture and the Co-operatives, therefore, announced a new conservational measure in July 1972 in accordance with the provisions of the Fisheries Act of B.E. 2490 (1947), commercial trawling operations of all types and sizes of trawlers are now prohibited within three kilometers off shores.

Planning

In recognizing the prominent role of fisheries in the supply of needed animal protein food, the Government of Thailand has incorporated the fisheries development program in its overall economic and social development plans since 1961. The Department of Fisheries, Ministry of Agriculture and Co-operatives, has already set up the current fisheries development program in the Third National Economic and Social Development Plan (1972-1976).

One of the most significant development policies at present is to initiate and promote the expansion of deep-sea fishing industry. Based on the Third National Economic and Social Development Plan, the Accelerated Program of Agricultural Development has been set up recently by the Ministry of Agriculture and Co-operatives. Because of its great demand in the international markets, marine shrimp is considered as one of the agricultural

Table I. Annual total fish landing in Thailand, 1964 – 1971 (estimated in tons) Fisheries Record of Thailand 1971, Statistics Section, Department of Fisheries, November, 1972.

Year	1964	1965	1966	1967	1968	1969	1970	1971
Marine fishes	494,196	529,483	635,165	762,187	1,004,058	1,179,595	1,335,690	1,470,289
Fresh water fishes	82,790	85,637	85,117	85,256	85,245	90,439	112,714	116,788
Total	576,986	615,120	720,282	847,443	1,089,303	1,270,034	1,448,404	1,587,077

Table II. Average catch rates obtained by M.V. 'Pramong 2' in systematic survey of demersal fish resources in the Gulf of Thailand by trawl net fishing, 1961 – 1972.

Year	No. of hauls	Catch rate kg./hr.	Yearly rate of decrease kg./hr.	Rate of decrease (base year, 1961)	Catch rate in % of 1961
1961	133	297.8	—	—	100
1963*	200	256.0	41.8	41.8	86
1964	182	225.6	30.4	72.8	75.9
1965	192	179.2	46.4	118.6	60.2
1966	713	130.8	48.4	167.0	43.9
1967	713	115.0	15.7	182.8	38.6
1968	719	105.9	9.1	191.9	35.6
1969	720	102.7	3.2	195.1	34.5
1970	718	97.4	5.3	200.4	32.7
1971	720	66.3	31.1	231.5	22.3
1972	720	63.1	3.2	234.7	21.2

*The average catch rate was obtained by M.V. 'Pramong 2' in the experimental trawling survey.

commodities of economic importance. The Department of Fisheries has therefore given full attention to the Shrimp Culture development. In the above-mentioned Program, the target has been set to reach a marine shrimp production of 112 thousand metric tons in 1976.

Generally, because of the limited amount of annual budget appropriated by the Government, some fisheries development projects have not been achieved soundly and rapidly. It is felt, therefore, that Thailand still needs foreign technical assistance in certain aspects of fisheries development.

Marine Resources

(a) Resources surveying, experimental and exploratory fishing, location of new fishing grounds.

The Exploratory Fishing Unit of The Department of Fisheries is responsible for the survey of pelagic and demersal fish resources and for the location of suitable fishing grounds in the Gulf of Thailand, the South China Sea, and the Indian Ocean including its contiguous waters. M.V. 'Fishery Research No. 1' of this unit has been assigned to undertake the demersal fisheries resources survey in the Gulf of Thailand and in the southern portion of the South China Sea since 1962, and the demersal and pelagic fisheries resources Survey in Andaman Sea and in the Indian Ocean has been carried out by M.V. 'Fishery No. 2' since 1965. The data obtained are being analyzed to ascertain the potential yields from and to promote the deep-sea fishing industry in the future. Furthermore, intensive exploratory and

experimental fishing, mainly with trawl and tuna longline, has been initiated in the Indian Ocean. An assessment of the stocks of demersal fish in the Gulf of Thailand made by M.V. 'Fishery Research No. 1' indicated that the demersal fish stocks have exhibited obviously a drastic decline from about 105 kg./hr. in 1969 down to about 88 kg./hr. in 1970 as revealed by the catch and effort study. (Data Report of the Exploratory Fishing UNit, No. SR 0110)

M.V. 'Pramong 2' of the Demersal Fisheries Investigation Unit of Marine Fisheries Laboratory has also been engaged in the monitoring survey of the demersal fish resources in the coastal waters of the Gulf of Thailand since 1964. Approximately 720 hauls of trawl net are made annually. The results of the survey indicated that there has been a steady decline in the average catch rate of this vessel from about 130 kg./hr. in 1966 to 63 kg./hr. in 1972. The catch rate in 1971 has decreased by more than 200 kgs. from 1961 which was the year that trawling was introduced to the Gulf of Thailand. (Table II) From the catch and effort studies of the total commercial catch landings from 1961 to 1969 (Table III), it seems reasonable to believe that the demersal fish resources in the Gulf of Thailand have reached the level of maximum sustained yield since 1966, with an estimated level of about 450,000 metric tons. The details of this studies appear in the Annual Report 1971 of Demersal Fisheries Investigations Unit, Department of Fisheries, prepared by Andhi P. Isarankura entitled "present status of trawl fisheries resources in the Gulf of Thailand and the management program."

Table III. The total commercial trawl catch landings and the catch rates of demersal fish as determined by the survey in the Gulf of Thailand, 1961 – 1969.

Year	Total landings (Metric tons)	Catch/hour (Kgs.)
1961	123,000	298
1962	151,000	277
1963	228,000	250
1964	372,000	226
1965	393,000	179
1966	449,000	131
1967	525,000	115
1968	784,000	106
1969	767,000	103

(b) Research and investigation on the biology and stocks of commercially important aquatic animals.

M.V. 'Pramong 1' and M.V. 'Pramong 6' of the Pelagic Fisheries Investigation Unit of the Marine Fisheries Laboratory have been undertaken several research projects with respect to the biology and/or stock of the pelagic fish species including *Rastrelliger* spp., *Scomberomorus* spp. and *Stolephorus* spp. The age determination study of the Indo-Pacific mackerel *Rastrelliger neglectus* (van Kampen) collected from various fishing grounds has been in progress. The assessment on the growth and mortality rates of the said mackerel tagged during 1969-1971 indicates the overall recapture of 8.68 per cent. Base on the analysis of the yield-per recruit models, the study on the population dynamics of the above mentioned fish in the Gulf of Thailand also indicated a possibility of increasing production by fishing intensity operations (Kurogane et al, 1970 and Hongskul, 1971)

The study on the biology of several demersal fish species including *Nemipterus* spp., *Saurida* spp. *Lutianus lineolatus* and *Sciaena russelli* (Cuvier) has been carried out by the Demersal Fisheries Investigations Unit of the Marine Fisheries Laboratory. The biological data on length, weight, maturity stage of the gonads and stomach contents of these species collected monthly are now being analyzed. Dart tags and plastic tape tags were used on eight species of demersal fish during the study of distribution and dispersion of the stocks.

(c) Fisheries oceanographic studies.

In accordance with the participation of Thailand in the CSK South China Sea program, M.V. 'Fishery Research No. 2' has made regular oceanographic surveys in the South China Sea. Such surveys consist of a number of physical and chemical observations. In addition, meteorological observations have also been conducted so that the data obtained can be beneficially employed by the Department of Meteorology in Bangkok.

Aside from this, M.V. 'Fishery Research No. 1 and M.V. 'Fishery Research No. 2' also perform the practical sea training to the students from the Faculty of Fisheries, Kasetsart University and from the Department of Marine Science, Chulalongkorn University for a specified period of time.

(d) Research programs and institutions

In order to expand fishing grounds on both the Gulf of Thailand and the Indian Ocean coasts to international waters, experimental and exploratory fishing operations are now in progress. Thai fisheries has grown up to high extent since the introduction of one boat bottom trawl, therefore it is necessary to improve types of the fishing gear used in order to obtain the better yield. The fishing gear experiment of various type of trawls in the Gulf of Thailand and in the Andaman sea within Thai-German Partnership in the field of fisheries has been carried out recently on the 6th of February 1973 at the Marine Fisheries Station, Rayong Province. The result of this particular experiment indicated high opening bottom trawls to become an important fishing gear, especially for the bigger boats working in the growing far distance fisheries. (Report on the experiment of various type of

trawls in the Gulf of Thailand and in the Andaman sea within Thai-German partnership in the field of fisheries, 1973. A paper submitted to the Department of Fisheries)

Aquaculture

(a) Shrimp culture

In 1971, 5593 tons of frozen shrimps of about 246 million bahts (US \$ 11.7 millions) which represent over 49% of the total foreign exchange earning of the fishery product; acceleration of the shrimp culture development is thus considered as part of the fishery development policy at present.

For present status of shrimp farming development, Thailand possesses most of the requirements favouring to the development of commercial farming. It has at present about 45,000 rai or 7,500 hectares of traditional type of shrimp pond, most of which could be improved to yield higher production, and there are over 300,000 rai or 50,000 hectares of coastal swamps and inland water having high potential for shrimp farming and prawn culture development. Aside from this, it also has a number of large, fast growing, and high quality shrimp and prawn suitable for culturing. Many species of penaeid shrimps such as *Penaeus semisulcatus*, *P. Monodon*, *P. merguensis* and *P. latisulatus* as well as the famous giant fresh water prawn *Macrobrachium rosenbergii* are available and can be collected for the purpose of shrimp seed production all year round. In addition, the climate conditions of the natural water are favourable for the growth of these large species which occur locally. All these factors provide very great potentials and possibilities for large scale of shrimp and prawn culture development. Under proper development and well managed shrimp farming program, an annual production of about 100,000 tons of prawns and shrimp can be expected.

1. Shrimp and prawn seed production

At present, the shrimp and prawn seed are solely obtained from natural stocks. This method of seed production is likely to be unsatisfactory. With regard to several species of shrimp, experiments on artificial seed production have been carried out on a commercial scale. Pilot shrimp hatcheries are to be built at three marine fisheries stations located in Songkhla, Phuket, and Rayong provinces. These shrimp hatcheries are planned to have capacity of about 100 millions of post larvae of the penaeid species for distribution to shrimp farmers.

2. Improvements of the traditional shrimp farms.

Shrimp culture technique currently adopted in Thailand is a traditional one. The shrimp farming production in Thailand varies according to location of the farms and farm maintenance. The average yield per unit area is very low being 54.5 kg./rai or 327 kg./ha. (Teinsongrusmee, 1970) and 21.8 kg./rai (result of cost and earning survey on shrimp culture in Thailand 1970 conducted by The Statistics Section, Department of Fisheries). Experimental and demonstrative shrimp farms using Japanese modern methods are to be built and operated. The techniques developed will be used as basis for improving the existing traditional shrimp farm for higher production, it is expected that the current annual yield of 325 kg./ha. will be increased to 500 kg./ha.

Investigations on appropriate methods and techniques of increasing production in shrimp culture are being carried out at the pilot farm at Samutsakorn and Samutprakarn provinces. Three major problems encountered during shrimp culture operations are the leakage of pond embankments, the enemies, and the insufficient amount of natural food in ponds. The above-mentioned problems have been solved by the use of plastic and cello-crete materials, the tea-seed cake application for killing fish, and the addition of superphosphate fertilizers resulting in approximately three-fold increase in yields.

3. Shrimp culture loan

A long term credit is needed for both development of intensive shrimp farmings and improvements of the existing indigenous farms. In view of the efficiency of loan management, the Bank for Agriculture and Agricultural Co-operatives (BAAC) is suggested to take the responsibility to operate on the shrimp farm loan. While the Department of Fisheries is to supply all technical assistance required by the BAAC. A working party composes of BAAC, the Department of Fisheries and concerned agencies are to be set up for the details project preparation with assisted by the Japanese experts.

4. Activities undertaken by the Department of Fisheries

The activities on the shrimp culture development both researches and field studies have already been initiated to some extent by various Marine Fisheries Stations of the Department of Fisheries. Projects being undertaken presently are as follows: -

Bangchan Fisheries Station : Shrimp rearing experiment in different sizes of ponds by using fertilizers and other supplemental feeds.

Rayong Marine Fisheries Station : A construction of a culturing concrete pond of 2 rai in area (approximately one Acre), has been completed and another one of approximately 5 rai is now being constructed.

Construction of six shrimp hatcheries of 400 tons in total volume for the experimentation on seed production. Two nursery ponds of 320 m² in area are now being constructed.

Songkhla Marine Fisheries Station: Construction of eight hatchery ponds of 5 × 5 × 2 m³ in size approximately of 400 tons in total volume for conduction of the marine shrimp seed production.

Construction of eighteen hatchery ponds of 2 × 10 × 1 m³ in size for *Macrobrachium* spp. seed production are now being constructed.

Construction of two juvenile stocking ponds of 5 × 10 × 1 m³ in size for rearing of juvenile shrimps.

Experimentation on rearing of juvenile shrimps to marketable size in brackish water ponds, ferro-cement pond and other fenced ponds.

Survey on the abundance and distribution of larvae along the coastal of Songhla and Pattani Provinces.

Phuket Marine Fisheries Station: Construction of a shrimp culturing pond of 3 rai in area and the hatcheries ponds of 80 and 260 tons in volume have been completed and another one of 260 tons is now being constructed for

Penaeus spp. seed production.

Post larvae of three species of marine shrimp *Penaeus semisulcatus*, *P. monodon* and *P. merguensis* were distributed to the shrimp farmers in southern part of Thailand.

5. Research program and investigations

Research program consist of three main objectives: -

Firstly, the development of modern culture techniques being promoted by newly enlarged experiment of the existing indigenous shrimp farm; secondly, providing proper foods for shrimp larvae; and thirdly, extension of the commercial shrimp farming industry in order to increase the export products.

Although researches and investigation on appropriate methods and techniques for increasing production are being initiated to some extent, however, foreign technical assistance in certain aspects of shrimp culture is still needed. At the request of the Thai Government, and the auspices of Government of Japan, a survey team consigned by the Japanese Overseas Technical Cooperation Agency has conducted a series of survey from 14-29 March, 1973 for the purpose of working out the details of the technical cooperation in the field of shrimp culture development in Thailand between the two countries based on the recommendation of the Japanese survey team which visited Thailand from 18 July to 7 August, 1972.

(b) Introduction of new cultivating marine fishes.

As far as the introduction of modern techniques in cultivating new species of marine fishes is concerned, considerable progress has been made in the artificial fertilization study of various commercially important pelagic fishes. Those species succeeded from the experiments are :-

Rastrelliger neglectus

Carans malam

C. leptolepis

C. mate

C. crumenophthalmus

Decapterus russelli

Lutianus vitta

Sciaena sp.

Sphraena sp.

Suarida sp.

In order to increase the foreign exchange earning through export of certain fishery products, studies on rearing of sea turtle and spiny lobster are now also being initiated at the Phuket Marine Biological Center.

Training

So far as the in-service training program is concerned, the Marine Biological Center at Phuket offer several training courses on various specialized fields of fisheries and related subjects to trainees selected from scientists and fisheries technical officers of the Department of Fisheries for a specified period of time. Kasetsart University offers instructional programs leading to Bachelor of Science and Master of Science degrees in fisheries biology, aquaculture, fisheries management, fishery products, fisheries technology, marine science, food science and related subjects. In addition, both undergraduate and graduate programs can also be pursued in the Department of Marine Science, Faculty of Science, Chulalongkorn Uni-

versity. A few general fisheries courses are offered to students in several agricultural schools and colleges of the Vocational Education Department of the Ministry of Education. Generally most scientists and fisheries technical officers of the Department of Fisheries are from the above mentioned university graduates, and extension workers from the vocational school graduates.

Fishing fleet

The present fishing fleet is estimated at about 40,000 boats and craft of various sizes, the majority being small boats with the long shaft outboard engines which fish in the inshore waters. In 1971, there are only 59 fishing vessels which proceed into deeper waters for their catches and two fishery research vessels of 131 and 388 GT. operated by the Department of Fisheries.

The current trend of boat building is for installation of higher horse-power engines on large vessels capable of fishing in distance waters. The maximum size of vessels constructed to date is reported to be a 35-m wooden trawler powered by approximately 1000-HP marine diesel engine; nine fishing boats of the same size and design are now being constructed by private fishing enterprises.

Fishing household

The number of fishing operator's household regardless of the size and fishing employee's households that engaged in fishing during 1971 was estimated at about 30,000 and 10,000 respectively. There is an increase of the number of fishing operator's households with more than three permanent employees, this is due to a fairly high productivity of off-shore fisheries, whereas a decrease of the number of fishing operator's households without any employees or with less than two employees is due partly to low productivity of in-shore fisheries and partly to an increase of employment chance with other industries.

Statistics

(a) Strengthening national statistical offices in order to introduce statistical systems.

The statistical systems providing information on marine catch landings and fishing efforts were formulated in 1969 by the Department of Fisheries. Such systems are continued by a working group of 73 enumerators and 5 supervisors.

(b) Availability of basic data on landings by species and areas, on fishing fleets, fishery output and trade.

The survey and annual catch landings at five major landing places has been commenced since January 1972. The survey aims at providing the landings in terms of quantity and value of fish by species. The fishing inventory items consisting of fishing house holds, fishing boats and fishing workers are collected biennially. The number of fishing fleets is counted by types of engines and by lengths of boats. Statistics of the annual catch landings during the last 30 years are now available. The data on the imports and exports of fishery products are obtained from the foreign trade statistics issued by the Department of Customs, Ministry of Finance.

Recent Trends in Production, Distribution and Demand

(a) Trend in Production, Quantity and Value.

According to the latest fisheries statistics, the total catches of both marine and freshwater fish increased from 1.48 million metric ton in 1970 to 1.58 million metric ton in 1971. As a result of the rapid development of commercial trawling, the marine landing accounted for about 80 per cent of the total fish production. The fishing yields have been utilized in the following way : fresh market fish 47 per cent; salted, dried or smoked 7 per cent; frozen 1.5 per cent; various processed forms 44.5 per cent.

(b) Trends in domestic demand, fresh vs. processed fish.

It should be noted that the quantity of fresh marine fish transported to the main consuming centers in the northern and northeastern province is extremely small as compared with a large quantity of fish landed at the Bangkok Fish Market. Generally, no cheap fresh marine fish of high quality are on sale in those provinces mentioned. As a matter of fact, handling and distribution of fresh fish is in general a great problem that faces Thailand at the present time. Consequently, the people in these regions prefers processed freshwater fishery products to the marine ones.

(c) Earning of foreign exchange through export of fishery products.

In 1971, Thailand exported approximately 55 thousand metric tons of fish and fishery products with the total value of about 497 million bahts (US \$ 23.50 millions); some 5593 tons of frozen shrimp at a value of about 246 million bahts (US \$11.70 millions) were exported to Japan, U.S.A. and Europe. The latter figure accounted for about 50 per cent of the total value of fishery products for export. The favorable balance of trade on fishery products was estimated at about 415 million bahts (US \$ 19.70 millions) in 1971.

Costs and Earnings

There has been no investigation to show any changes in input costs and profitability of the fishing operations as a whole in the country. However, the cost and earning surveys of trawlers and shrimp culture operations have been conducted since February 1969. The details of this studies appear in the result of cost and earning survey on shrimp culture in Thailand, 1970 conducted by the Statistic Section, Department of Fisheries.

Financing the Industry

At present, the main sources of financial assistance available to fishermen and fish processors are provided by several financial institutions, namely: the Department of Fisheries, the Bank for Agriculture and Agricultural Co-operatives the Industrial Finance Corporation of Thailand and all commercial banks. A total amount of 7.57 million baht loan granted by the Department of Fisheries to fisherman in 1971 is extremely limited. Therefore, the Department of Fisheries has recently requested a 50-million bahts revolving loan fund from the

Asian Development Bank for fisheries loans. In 1971, a fisheries loan fund of 6.32 million bahts was granted by the Agriculture and Agricultural-Cooperatives Bank which is a government-owned financial institution. Deep-sea fishing, fish cultivation and fish-processing industries are the industrial fisheries enterprises being eligible for the loans provided by the Industrial Finance Cooperation of Thailand. The maximum loan amount per borrower is 30 million bahts grants for up to 7 years at the rate of interest of 10.5% per annum. Fishermen and fish processors may apply for loans from any commercial bank; such adequately secured loans will be granted at the interest rate of 14% per annum.

Technical Assistance

Foreign expertise for fisheries development is being utilized by Thailand under a bilateral agreement with the Federal Republic of Germany relating to the establishment of the Marine Fisheries Laboratory. Under the Thai-Danish Co-operation in the field of marine biology; Marine Biological Center has been established in 1971 at Phuket province. Expertise in recent years is obtained mostly for introducing improved techniques of fishery. Besides the utilization of the services of foreign experts technical assistance is also achieved by deputing the selected candidates to foreign countries for specific training.

SEAFDEC/SCS. 73:S-32

The country report of the Republic of Vietnam Fishers Resources of Vietnam

by
Le-Van-Dang
Directorate of Fisheries
Republic of Vietnam

Abstracts

With cease fire and the reestablishment of peace in Vietnam, the country should be in a position to make major advance towards becoming self supporting and an economically stable nation. To achieve this end, every material and resource must be effectively used. Among the natural resources, fishery products represent an important contribution and a major factor in supplying the much needed additional protein food needs of the people. At the same time it may be possible to supply quantities of exportable fishery products to earn foreign exchange. In 1972, total fishery production was 677,700 MT from which about 2,000 MT of shrimp have been exported with a value of 6 million US\$.

Fish resources of Vietnam come from: (1) Inland waters (fresh water and brackish water) including the swampy and flooded areas of the Mekong Delta and an inextricable network of rivers and canals throughout the country. Most of the tropical species of fish of the Indomalaysian archipelago are found in inland waters. Some are widespread and are used for local consumption. These include snake-head fish and *Trichogaster* which are caught in flooded rice field and other types like common carp and catfishes which are cultivated in fish ponds. Some introduced species such as the Chinese carp promise to be adaptable to the local conditions. (2) Marine waters (inshore and offshore) abound with common species of the South China Sea and the Gulf of Thailand. These include red snappers, mackerel, threadfin, pomfret grouper squid, herring, lizard fish, etc.... Shell fish, such as shrimps and prawns, lobsters, mussels, clams, and crabs are also taken in variable quantities depending on the area.

Due to the geographical situation of the country adjacent to the wide continental shelf of most of

Southeast Asia, Vietnam has a great potential for development of fishery resources. In spite of the ravaging war that hindered fisheries from developing, our production of fish in 1972 reached about 677,700 tons, comprised of more than 500,000 tons of marine products, 82,000 tons of fresh water fishes and about 96,000 tons of shrimp, crab and molluscs combined.

Nearly all of these resources were used for local consumption. The small remainder, some 2300 MT with high unit value in the international market were exported and brought nearly 6 million US\$ into the trade balance. Export species include shrimp, polynemous threadfin, pomfret, red snapper, squid etc....

1. FRESH WATER AND BRACKISH WATER RESOURCES

Almost all tropical water resources are found in Vietnam, especially in the south west region flooded every year by the Mekong River. Many farmers in this region are also part-time fishermen. They use many kinds of fishing gears and small outboard boats for fast transportation of their catch to the market. Deep ponds near the rice fields are used for fish concentration when the water runs down toward the river.

The main species caught in the south west are as follows:

English name	Scientific name
Snake head fish	<i>Ophicephalus striatus</i> , and <i>Ophicephalus micropeltes</i>
Fresh water catfish	<i>Clarias batrachus</i> , and <i>Clarias fuscus</i>
Climbing perch	<i>Anabas testudineus</i>

Rice field eel	<i>Fluta alba</i>
Fresh water prawn	<i>Macrobrachium</i> sp, and <i>Macrobrachium rosenbergii</i>

Many other fresh water species are cultivated in ponds, lakes or rivers. Some of them, such as *Pangasius* and *Puntius javanicus* are reared in floating bamboo cages.

Government hatcheries provide fingerlings at low price to farmers. Indonesian carp, Chinese carp, kissing gourami and tilapia are reared throughout the country.

Some species of fingerlings, such as silver carp (*Hypophthalmichthys harmandi*) and grass carp (*Ctenopharyngodon idellus*) must now be imported. However local production by induced spawning is under experiment and promising results have been obtained.

Fry of fresh water catfish (*Pangasius pangasius*) can be collected in the Mekong River for rearing in ponds.

Brackish water fish (milk fish, mullet, tilapia) and shrimp are reared in thousands of acres of low lands and in mangrove areas along the coast, especially in the south west region. Milk fish fry are also available seasonally along the central Vietnam coast.

2. MARINE RESOURCES

1. Offshore resources

A survey made by two research boats, the *Kyoshin Maru 52* and the *Friendship* shows that the main species of fish living offshore of Vietnam are:

English name	Scientific name
Red snapper	<i>Lutjanus sanguineus</i>
Big-eye snapper	<i>Priacanthus macracanthus</i>
Cuttle fish	<i>Specia framea</i>
Travalley	<i>Alectis ciliaris</i>
Horse mackerel	<i>Magalapsis anomala</i>
Silver carp	<i>Psenoppsis anomala</i>
Dog head fish	<i>Saurida undosguamis</i>
Markerel scad	<i>Tnachurus japonicus</i>
File fish	<i>Amenses tossellatus</i> , and <i>Amenses hodlestus</i>
Ray	<i>Hypolophus sephen</i> , and <i>Miliobatus tobijei</i>
Horse shoe crab	<i>Ibacus ciliatus</i>

In addition, our trawlers have often caught the following species:

English name	Scientific name
Goby	<i>Glossogobius biocellatus</i>
Flat fish	<i>Psottodes erumei</i>
Lizard fish	<i>Saurida</i> sp.

Grunter	<i>Pomadasy kasta</i> , <i>Plustorhynchuc celebicus</i> , and <i>Parapristipoma trilineatus</i>
Catfish	<i>Netuma thalassimus</i>
Threadfin break	<i>Nemipterus taeniopterus</i> , and <i>Nemipterus tambuloides</i>
Hairtail	<i>Trichiurus lepturus</i>

2. INSHORE RESOURCES

The inshore fishing grounds are so heavily exploited that we must now think about possible overfishing. Fishermen use all kinds of fishing gear and adopt quickly to new techniques. Shrimp of all sizes bring a high price in the domestic market and the larger sizes are much desired in the international markets. Hundreds of fishing boats are trawling day and night for shrimp.

The main species caught are as follows:

English name	Scientific name
Tuna	<i>Scomberomorus commersoni</i>
Mackerel tuna	<i>Euthynnus affinis</i>
White pomfret	<i>Pampus argenteus</i>
Threadfin	<i>Polynemeus</i> sp.
Sea perch	<i>Psammoperca waigieusis</i>
Grouper (reef cod)	<i>Epinephelus</i> sp.
Flat fish	<i>Psettodes erumi</i>
Tassel fish	<i>Sciaena dussumieri</i>
Spotted spanish mackerel	<i>Cybium guttatum</i>
Squid	<i>Thysanateuthis rhombus</i>
Cuttle fish	<i>Sepia esculenta</i>
Catfish	<i>Netuma thalassimus</i>
Herring	<i>Harengula</i> , sp.
Lizard fish	<i>Saurida</i> , sp.
White tipped mackerel (scad)	<i>Decapterus maruadsi</i>
Red snapper	<i>Lutjanus sanguineus</i>
Dog shark	<i>Scoliodon palasorrh</i>
Manta ray	<i>Dasyatis</i> sp.
Anchovy	<i>Clupesides bornensis</i>
Flying fish	<i>Cypselarus artisignis</i>
Grunter	<i>Flectorhynchus celabious</i>
Threadfin	<i>Polynemeus bornensis</i>
Threadfin bream	<i>Nemipterus bleekeri</i>
Hairtail	<i>Trichiurus lepturus</i>
Pig face break	<i>Penptapodus setosus</i>
Shrimp	<i>Penaeus</i> sp. <i>Metapenaeus ensis</i> , and <i>Parapeneopsis affinis</i>

Lobster (spiny)	<i>Panulirus fasciatus</i>
Mysid	<i>Neomysis Japonica</i>
Mussels	<i>Mytilus crassitesta</i> , and <i>Mytilus edulis</i>
White clam	<i>Meretrix meretrix</i>

Many other fishes are caught. Due to our lack of ichthyologists and biologists, an accurate determination of their species cannot be made for the time being.

PART II TECHNICAL PAPERS

THE PELAGIC RESOURCES

SEAFDEC/SCS. 73: S-24

A PLAN FOR THE DEVELOPMENT OF SEA FISHERIES IN THE PHILIPPINES¹

by
The Technical Staff
Bureau of Fisheries
Department of Agriculture and Natural Resources
Republic of the Philippines

1. INTRODUCTION

The demand for fish in 1973 is estimated at 1,635,600 metric tons, but the fisheries industry is expected to produce only 1,610,500 metric tons or a deficiency of 25,100 metric tons.

The Philippines has had to import fish annually to make up for this deficiency. The inability of the fisheries industry to meet the demand can be attributed to a number of problems. Foremost among them are:

1. Low productivity and declining yield of areas presently exploited and under-exploitation of many areas of fishery resources.
2. Lack of adequately trained manpower.
3. Lack of capital credit facilities.
4. Poor marketing and distribution of fish and other aquatic products.
5. Lack of ports, harbors, ice plants and cold storage, etc.
6. Need for the improvement of traditional products and development of new ones for export and for import substitution.

The Government through the Bureau of Fisheries hopes to solve these problems and consequently to increase fish production by implementing one or a combination of the following measures:

1. Increase the yield per hectare of inland waters and the catch per vessel; or
2. Increase the area for fishponds and the number of fishing vessels.

To accomplish them, the Bureau of Fisheries has prepared a fish expansion program which aims not only to achieve self-sufficiency in fish by late 1974, but also to be able to produce, starting in 1975, enough to meet both domestic and export needs.

Thus a loan proposal to the World Bank was made for the expansion of the production capacity of the fisheries industry through improvement of productivity levels in

the fishponds, deepsea and municipal fisheries sectors.

This paper proposes a credit scheme whereby funds would be secured from the World Bank through the Development Bank of the Philippines to finance the acquisition of modern fishing equipment like engines, power blocks, winches, nets, navigational aids, fish finders, etc. and to support the investment needs for the acquisition of new fishing boats and fish carriers.

2. THE SEA FISHERIES PROJECT PROPOSAL

2.1 Project description

Basically, the project is a financing scheme designed to support the sea fisheries program directed at the improvement and expansion of the existing fleet. The project includes the acquisition of catcher and boats, carrier and the improvement of existing catcher boats (*i.e.*, installation of winches, power blocks, better engines and nets, motorization of bancas, etc.).

A more detailed breakdown of the composition facilities which make up the project are as follows:

Addition to the existing fleet:	No. of Units
1) 70-90 GT Trawlers	20
2) 20 GT Trawlers	20
3) Pure-seiners	20
4) Combined Trawler Purse-seiners	10
5) Carriers	(No definite no.)
Improvement of existing fleet:	
1) Trawlers and Purse-seiners	120-150
2) Mechanization of "bancas"	6,000

1. Most of the data included in this paper were based on a project study presented to the World Bank to develop the fishery industry.

2.2 Targets

2.2.1 Target setting methodology

The shares of the sea fisheries industry of the desired incremental fish demand requirement in the next few years which need the support of banking institutions were approximated.

In the consideration of the project targets, these figures were regarded as ceilings within which the targets must be set.

After the ceilings were established, an attempt was made to assess the facility needs of the sector. Since data on this matter are most scarce, the value judgement of the FAO/UNDP and the Bureau of Fisheries people who are most familiar with the private sector was mainly relied on. Care was taken so as not to overshoot or exceed target ceilings earlier established. The number and types of facilities needed were determined. These figures are most proximate and tentative and were attempted only so as to arrive at a basis in the computation of project investment requirements.

2.2.2 Output targets

The project is aimed at producing some 58,300 metric tons of fish in a span of 4 years or at increasing the existing fish catching capacity by about 58,300 metric tons per annum in the 4th year.

The target is further broken down into two (2), namely: targeted production from new boats set at 47,000 metric tons and targeted incremental production from the improvement of the existing fishing fleet set at 11,300 metric tons. A yearly breakdown of these 2 lines of activities under the project is presented below.

	Year			
	1	2	3	4
Production of new boats	0	11.7	30.6	47.0
Incremental Production of Existing Fleet	3.8	7.6	11.3	11.3
Total	3.8	19.3	41.9	58.3

2.2.3 Types and number of facilities targeted to be included in the project

The types and number of facilities needed to effect the project's targeted output were approximated. Presented below is a more detailed breakdown of these facilities.

Table 2. Known ground for purse seining (middle-distance)

Area	Distance-Mile		Months	Fish	Fathoms	Quantity per day, tons		Percentages
	Shore	Base				From	Total to 6	
Cuyo and North Palawan	10-20	250	May to July	Round Scad	40	2.2	4.0	55
				Mackerel		0.5		12
				Sardines		0.6		
				Others		0.7		
				Total to 6		4.0		
Sibuguey Bay and Turtle Island	10-60	500	August to October	Round Scad	30-35	1.8	4.0	45
				Mackerel		0.6		15
				Sardines		1.0		25
				Others		0.6		15
				Total to 6		4.0		

Table 1. Types and number of facilities to be financed under the project

Types of facilities	Year			Total
	1	2	3	
Trawlers (70-90 GT)	5	5	10	20
Purse Seiners	5	10	5	20
Combined Trawler Purse Seiners	2	4	4	10
Trawlers (20 GT)	10	10	-	20
Motorization of bancas	2,000	2,000	2,000	6,000

No attempt was made at specifying the type of carrier recommended for the project. Consequently no approximations of number were made. In the improvement of the existing fleet, no details were attempted as it was most difficult to approximate the scope of improvement which may be included under the project.

2.3 Project area

The project is envisioned to cover the fishing areas within the country's territorial water and nearby areas in the South China Sea and the Pacific Ocean. The types of fishes within these fishing grounds include different species of anchovy, big-eyed scad, chub mackerel, round scad, sardines, tuna, albacore, bonito, cavalla, crevalle, croakers, goatfish, hairtail, cutlass, nemipterid, shrimps and slipmouths.

2.3.1 Area of fishing operations

Two schemes of possible operating schedules in the presently known grounds and in new grounds still inadequately explored are envisioned under the project. If the exploration is successful, the pattern would be for most vessels to operate on known grounds initially, with an increasing shift to new grounds as these prove workable. The aggregate data in reference to areas, distances, seasons and catch rates are given as follows:

Table 2a. New grounds for purse seining (long-distance)

Area	Distance-Mile		Months	Fish	Fathoms	Quantity per day, tons	Percentages
	Shore	Base					
South China Sea	200	600	August to November	Round Scad	60-80	From 6.8	?
				Mackerel		?	
				Sardines		?	
				Others		8.0	?

Table 3. Known grounds for trawling

Area	Distance-Mile		Months	Fish	Depth Fathoms	Quantity tons	Percentages
	Shore	Base					
Visayan Sea	10	300	December to February	Mackerel	2-40	0.5	20
				Shrimp		0.1	5
				Others		1.9	75
West Sulu Sea	15-20	400	March to April	Mackerel	60-100	0.3	8
				Shrimp		0.1	3
				Others		3.1	89

Table 3a. New grounds for trawling

Area	Distance-Mile		Months	Fish	Depth Fathoms	Quantity tons	Percentages
	Shore	Base					
South China Sea	200	1,500	December to April	Snappers Groupers Others	60-100	4.5	?

2.3.2 Weather conditions

There are four major factors in the Philippine weather conditions which affect fishing operations. Three of these are reasonably regular and predictable. The wind blows from the southeast during the period February to May, from the southwest from June to September and from the northeast from October to January. There is commonly a spell of fairly rough weather associated with each change in wind direction, but this dies down fairly quickly. The main weather hazard is that of typhoons and tropical storms. These can occur at any given time of the year. They are, however, rare south of latitude 8°N. All fishing operations come to a complete halt when a typhoon is reported to be approaching. Its effects last from 3-7 days normally. Ten to twenty (10-20) typhoons may affect the country seriously in a bad year. Better years have much fewer typhoons.

Generally speaking, weather conditions are consistently better the farther south one goes.

2.3.3 Estimated total sample catch for a six-month period by region

The reported catches for a six-month period from the different regions are hereunder shown:

Table 4. Estimated catch by region

Region	Places Covered	Catch in tons (6 months)
I Dagupan City	Curimao, Bobon, Nagabungan Tulnagan, La Paz, Coyodon Binabalian, Silagui, Balinasay, Ilong Malinao, Luciente, Salud, Pilar Deway and Victory	474.6
II Aparri	Cagayan, Aparri, Ballesteros Buguey, Gonzaga, Sta. Ana	490.0
III Navotas	Balayan & Nasugbu Bay Calaca, Taal, Batangas Bay, Palawan Manila Bay, Honda Bay & Sulu Sea	2,956.0
IV Naga	Ticao Pass, Sorsogon, Albay Gulf Tabaco & Tiwi, San Miguel Bay & Adjacent Ragay Gulf, Paracale, Lamon Bay, Calaguas Is., Burias Pass, Asid Gulf & Sibuyan, Cataingan Bay	45,793.68
V Iloilo City	New Washington, Kalibo, Numancia Makato, Tangalan, Pandan, Libertad Antique	687.2
VI Cebu	Calbayog, Zumarraga, Tarangan, Daran, Maqueda Bay	1,057.2
VII Zamboanga City	Batu-Batu, Bongao, Dapitan City, Dipolog City, Basilan City, Malangas, Margosatubig, Naga, Pagadian, Tukuran	1,767.0
VIII Davao City	Celebes, Sarangani Pujada Bay	989.6 (5 mos. only)

2.3.4 Estimated catch/unit of effort

The estimated catch per unit of effort in the different fishing grounds is tabulated below:

Table 5. Catch per unit effort in different fishing grounds

Fishing ground	KG./Hr.	Daily ave. catch
Tayabas Bay	35.6	302.6
Iloilo	35.6	302.6
Lucena	57.2	486.2
Zamboanga	68.0	578.0
Naga	61.64	423.9
Guimaras Strait	25.6	217.6
Visayan Sea	125.2	1,064.2
Sorsogon	20.2	171.7
Palawan	41.6	353.6
Bacolod	42.4	360.4
Samar	26.2	222.7

2.3.5 Estimates of potential of Philippine waters¹

The Fish landings from marine waters in the Philippines have been estimated by the Bureau of Fisheries at 926,000 tons for 1971. (This does not include the figures for crustaceans and mollusks.) Of this total, commercial fishing vessels accounted for about 382,300 tons. (As this is the only sector for which any breakdown of the catches exists, estimates of the fishing potential must lean heavily on the data from this sector.)

The statistics recognize nine different types of commercial fishing gear. Of these, six are essentially aimed at pelagic fish species, the bagnet, purse seine, beach seine, round haul seine, long line and gill net, listed in the order of productivity. In 1971, the pelagic gear accounted for 43% of the commercial landings. The remaining three demersal fishing gear are the otter-trawl, muro-ami and hook-and-line, which made up the balance (57%) of the commercial landings. If the species composition is examined, it will be noted that there is a considerable overlap: the pelagic gear catch significant quantities of fish caught mainly by demersal gear and vice-versa. For example, in 1969, demersal gear landed about 9,400 tons of big-eyed scad (*Caranx crumenophthalmus*) as against 7,600 tons for pelagic gear. In the case of chub mackerel (*Rastrelliger brackysoma*) the values are 11,500 tons for demersal and 12,400 tons for pelagic fishing gear. If we define demersal fish and pelagic fish in terms of the gear which catches a majority of each kind, we find that the pelagic catches include about 9% of demersal species and the demersal catches include about 13% of pelagic species. The point involved in making the distinction is that in the absence of detailed information, it is reasonable to associate total quantity of demersal fish with the area of shallow waters, and as it happens, the cross-over of species between the fishing gear categories more or less cancels out.

Studies from other parts of South East Asia, notably the Gulf of Thailand (Tiews, 1966) indicate a productivity

1. Refer to "Marine Fisheries Potential in the Philippines and South East Asia" by Einar R. Kvaran. Published in the Fisheries Newsletter (July-Dec. 1971), the Bureau of Fisheries.

of 30-40 kg./ha. If this value is applied to the Philippine waters of less than 100 fathoms deep, an area of about 200,000 square kilometers, we arrive at a total potential for demersal species of 600,000 - 800,000 tons.

The Food and Agriculture Organization of the United Nations has also made estimates of the fishery potential of Philippine waters in a paper by Shimura and Gulland (1970) included in "The Fish Resources of the Ocean". Their estimate of the total potential of the demersal resources of the Philippines is 600,000 to 1,000,000 tons, and is in good agreement with the estimates of 600,000 - 800,000 tons arrived at above.

2.3.6 Harbour facilities

At present there is not a single fishing harbour in the Philippines despite existence of a commercial fishing fleet of some 2,200 vessels aggregating to 90,550 gross tons. Provision has, however, already been made for the construction of the first fishing harbour at Navotas, Rizal with loan assistance from the Asian Development Bank. This harbour will take care of the needs of the single largest group of vessels, some 758 fishing craft based in Rizal Province and Manila with a gross tonnage of 53,129 tons.

The regions most in need of fishing harbours after Navotas, are Southern Luzon and the Visayas in Fisheries Regions No. III and No. V.

The remaining six Fisheries Regions have much smaller fleets and the urgency of constructing harbours there is much less, in the absence of a specific, regional development plan of sufficient magnitude to warrant harbours specially connected with such a plan. While it is to be expected that regional development will become a feature of future plans, the present approach is essentially on a country wide basis, and the growth of fleets is expected to take place mainly in the existing larger fishing centers.

As can be seen from the latest available Fisheries statistics, only Region III (excluding Manila and Rizal) and V have landings in excess of 10,000 tons per year. The rationale for harbour development in these two Regions is somewhat different. In Region VI there is an urgent need for harbours to cater to the immediate needs of the existing fleet and anticipated expansion. In Region III the need is more related to the economics of diverting the supply of fish required for the Greater Manila area through a harbour conveniently located for vessels fishing in waters in the center and southern part of the archipelago.

The particular sites within Region III and Region V where harbours are most urgently needed are:

- 1) Dalahican, Lucena, Quezon Province
- 2) Bacolod, Negros Occidental
- 3) Cadiz City, Negros Occidental
- 4) Iloilo City, Iloilo

Detailed studies on these sites have not been carried out yet. In its submissions for proposals of the Country Programme for UNDP assistance in 1972-1976 the Bureau of Fisheries included provision for expert assistance for a project on the location and design of seven secondary fishing harbours. Due to budgeting difficulties this request was excluded from the final NEC submission

to UNDP. In May 1971, a fisheries review and identification mission from FAO/IBRD Cooperative Programme visited the Philippines. The mission considered that three more or less distinct categories of development in landing facilities may be considered:

- 1) Fishing ports proper, capable of handling vessels up to 100 tons or so;
- 2) Facilities for fishing boats in conjunction with commercial harbour development; and
- 3) Minor improvements in existing landing sites.

2.4 Project cost estimate

With the types and number of facilities to be included in the project determined, the project costs were calculated. The targeted yearly expenditures presented below were arrived at based on the phasing of acquisition of the project facilities.

Table 6. Cost estimates (in millions) of the sea fisheries project

	No. of units	Cost/Unit	Total M. P	Total M. \$
Marine operations				
A. New Construction				
1. Middle & distant water				
1.1 Trawlers-70-90 GRT	20	1.15	23.0	3.8
1.2 Purse Seiners	20	1.00	20.0	3.3
1.3 Combined Trawler/Purse Seiner	10	1.30	13.0	2.2
2. Near Water				
2.1 Trawlers - 20 GRT	20	0.15	3.0	0.5
B. Improvement of Existing fleet				
1. Trawlers & purse seiners	-	-	9.0	1.5
2. Mechanization of "bancas"	6,000	1.50	9.0	1.5
C. Carriers	-	-	21.0	3.5
D. Working Capital (@ 10%)	-	-	-	1.5
Total for marine fishing				17.8

Table 7. Phasing of total project costs (in millions of pesos)

	1		2		3		Total P Mil.
	Units	P Mil.	Units	P Mil.	Units	P Mil.	
Trawlers 70-90 GRT	5	5.75	5	5.75	10	11.50	23.00
Purse Seiners	5	5.50	10	10.00	5	5.00	20.00
Comb. Trawler-Purse Seiners	2	2.60	4	5.20	4	5.20	13.00
Trawlers 50 GRT	10	1.50	10	1.50	-	-	3.00
Sub-total	22	14.85	29	22.45	19	21.70	59.00
Improvement of Existing Fleet	-	3.00	-	3.00	-	3.00	9.00
Mechanization of "bancas"	-	3.00	-	3.00	-	3.00	9.00
Deep sea fishery total		20.85		28.45		27.70	77.00

2.5 Benefit-cost analysis

As was earlier mentioned in the economic evaluation of the fishpond models under the project, the IRR is felt to be adequate for the purposes of this project.

Assuming an output price of P1,500 per metric ton of fish, an evaluation of fisheries projects revealed the following results:

Table 8. Internal rates of return of sea fisheries projects

	IRR
Purse Seiners	49
Trawlers 70-90 GRT	36
Trawlers 20 GRT	36
Combined Purse Seiner-Trawler	44
Carriers	-
Improvement of existing commercial fleet	-
Motorization of bancas	-

Compared with the accepted standard of 20% for agricultural or non-agricultural enterprises in developing countries, the above-mentioned results appear to be fairly high and hence, feasible and acceptable.

3. CONCLUSION

Of the estimated P209 million which will be required to finance the entire loan project proposal, an estimated P107 million will be required to finance the sea fisheries sector. Of the initial working capital requirement of the enterprises to be financed, P9 million will be for this sector. The bulk of the project cost is estimated at P98 million.

The Philippine negotiating panel composed of officials from the Development Bank of the Philippines, Department of Finance and the Department of Agriculture and Natural Resources is now in Washington negotiating with the officials of the World Bank for the terms and conditions of the loan. It is hoped that at this time of writing the proposal has been approved and the loan documents already officially signed.

REFERENCES

- Anonymous. Fisheries Statistics of the Philippines: 1971, 107 pp.
- Kvaran, E. R., Marine Fisheries Potential in the Philippines and South East Asia. Fisheries Newsletter. (July-December 1971) 8-17.
- Philippine Fisheries Commission et. al., Philippine Fisheries Industry Development (A Loan Proposal to the World Bank) (April 1972), 326 pp.

Tuna and tuna-like fish resources in the South China Sea
and adjacent waters

by
Shoji Kikawa
Far Seas Fisheries Research Laboratory
Shimizu, Japan

Abstract

The distribution of tunas and billfishes in the South China Sea and the Southeast Asian waters was shown on the commercial longline data.

The seasonal changes in the hook-rate and the size composition of the yellowfin and bigeye tuna in the South China Sea were given and the previous suppositions on their stock structures in adjacent areas, the Indonesian waters and the Indian Ocean, were reviewed.

The estimated Japanese longline catches from the South China Sea attained their peak of about 6,800 tons in 1967 and since then they have fluctuated between 2,000 and 5,000 tons with somewhat downward trend. The yellowfin and bigeye tuna accounted for ninety percent of the Japanese catch more. The remainder was occupied by the billfish, mostly the blue marlin and black marlin. The total longline catch by the Japanese and Taiwanese fisheries from the South China Sea area were roughly estimated to be between 5,000 and 8,000 tons in a recent few years.

Among the small-sized tuna and tuna-like fishes, the skipjack, little tuna, longtail tuna, frigate mackerel and bonito seemed to be promising for their future exploitation. The biological information on some of them was briefly reviewed.

Recent activities in research on tuna fisheries in the Indo-Pacific areas (IPFC area) have been fully reviewed by Suda (1971). For the South China Sea area, however, little has been reported on the biology of large-sized tuna except a few studies (Nakamura, 1953), although this area has long supported the tuna longline fleets from Taiwan and Japan. The purposes of this paper are: (1) to show the distribution of tunas and billfishes caught by the Japanese commercial longline fishery in the South China Sea and its adjacent waters on the past data, (2) to show the recent trend in the longline catches from these areas and (3) to make a short review on the occurrence of small-sized tuna and tuna-like fishes in Southeast Asian waters.

1. AREAS CONSIDERED

The South China Sea area and the Southeast Asian waters are here arbitrarily defined as in Figure 1.

Since the South China Sea has the inflows of the North and South Equatorial Currents from the south of the Philippines, it is influenced by the Pacific waters rather than the Indian Ocean waters (Wyrski, 1961, FAO, 1972). It is, on the other hand, under the influence of the wind system which dominates the northern half of the Indian Ocean. This monsoon climate with alternating seasonal winds makes the flows along the mainland coast

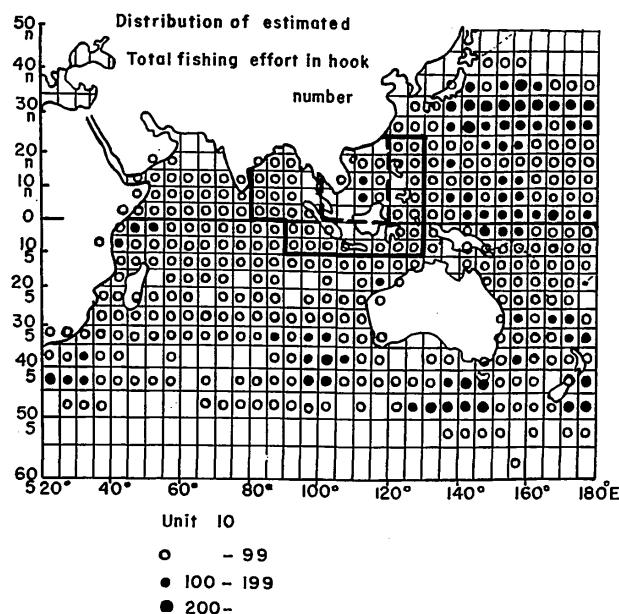

Fig. 1 Definition of areas and distribution of estimated total fishing effort in number of hooks (1971).

Solid line, Southeast Asian waters.

Hashed line, South China Sea area.

From "Annual report of effort and catch statistics by area on Japanese longline fishery" (1973)

change their direction. The longline fishing grounds are formed from the central to the northeastern part of this area and never extend to the west along the southeast coast of Vietnam. This is related to the depth of the sea. In the South China Sea, the vast continental shelf waters with depths of less than 150 m stretch to the south and west while in the central and northeastern parts east of approximately 110° E. longitude, depths exceed 4,000 m. Such a topographic feature limits the westward expansion of the areas of the longline fishery which takes tuna at a depth of about 100 m or more.

2. FISH CAUGHT BY LONGLINE FISHERY

Four species of the genus *Thunnus*, i.e. the yellowfin (*T. albacares*), bigeye (*T. obesus*), albacore (*T. alalunga*) and bluefin (*T. thynnus*) and five species of the Family Istiophoridae, i.e. the sailfish (*I. platypterus*), shortnose spearfish (*T. angustirostris*), striped marlin (*T. audax*), blue marlin (*M. mazara*) and black marlin (*M. indica*), are caught on the longline in the South China Sea. Sporadic catches of the broadbill (*X. gladius*) and the deep-swimming skipjack (*E. pelamis*) are also made. Sharks are sometimes an important item in the longline fishery in this area. All of these fishes, however, are not equally important in quantities; the yellowfin and bigeye and some billfishes have been supporting the South China Sea fishery.

2.1 Yellowfin tuna

2.1.1 Distribution and seasonal change in hook-rate.

The yellowfin tuna are distributed most densely in the South China Sea and the Southeast Asian waters and are undoubtedly important among tunas in these areas.

Figure 2 indicates the distribution of the apparent relative abundance as expressed by the hook-rate in each 1-degree square. The figures have been prepared on the longline data from 1952 to 1961 and are shown by picking up the highest value of the monthly averaged hook-rate for each square during the three-month period, for April-June and October-December, respectively. The areas of the high hook-rate occur in the central part of the South China Sea. Their eastern fringe does not reach the line through Taiwan and Luzon, which borders the

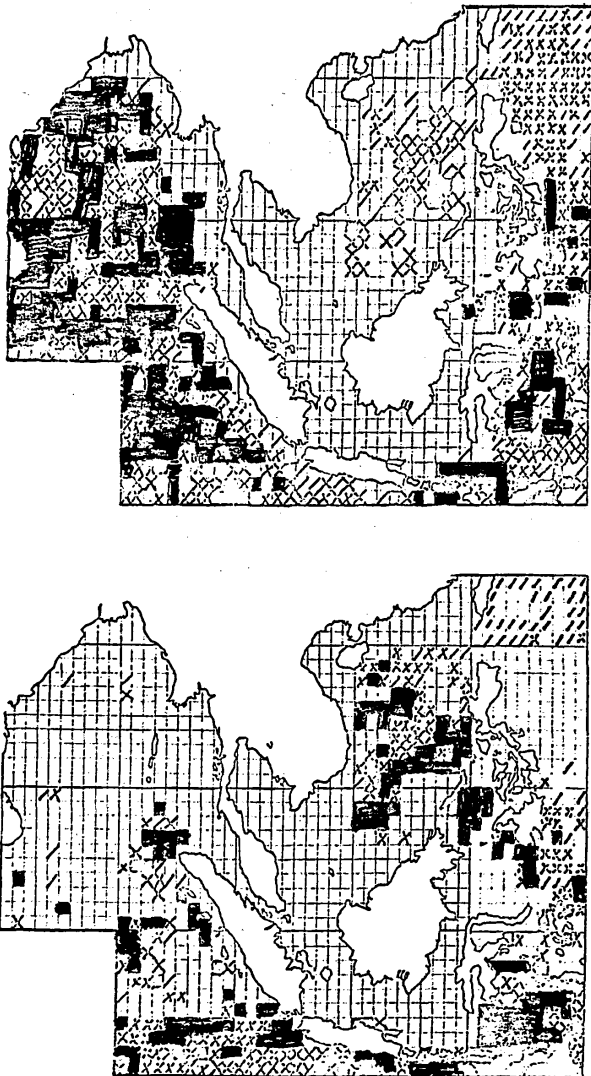

Fig. 2 Distribution of yellowfin tuna, as seen from the hook-rate of the Japanese tuna longline fishery. Upper, April-June. Lower, October-December. Black, cross and oblique lines indicate areas with hook-rate of 3.1 and greater, 2.1-3.0 and 2.0 and smaller, respectively. Figures are shown with combined hook-rate for three-month period. Data mostly from 1952 to 1961.

western-most contour of the Pacific Ocean. These areas on the other hand, appear to be continuous to the Banda-Flores Seas or to the western equatorial Pacific from the south of Mindanao. Such a pattern of the apparent distribution may suggest the relationship of the fish in the South China Sea with those in the southern areas.

Figure 3 shows the seasonal change in the hook-rate for the South China Sea. It indicates the average catch conditions for the period from 1930 to 1956, excluding the war time. As is observed clearly, the hook-rate changes with the season; it is relatively high from October to May and low during the rest of the year. The months of the lowest hook-rate are July and August, which correspond to the southwest monsoon season. In the Indonesian waters such as the Banda-Flores Seas, the seasonal change in the hookrate appears to be more complicate, according to the previous study (Mimura and Nakamura, 1959).

2.1.2 Size composition

The size of the fish caught on the longline in the South China Sea, according to the information from the monthly report of Taiwan Fisheries Research Institute, ranged from 100 to 170 cm in length, but most of them were between 120 and 150 cm (Kikawa and Anraku, 1959). The monthly size composition based on these data, as shown in Figure 4, appear to suggest the alternation of the fish during the months between about July and October. The period of such an alternation of the fish nearly coincides with that assumed from the monthly change in the hook-rate. To make this point clearer, detailed analyses should be done with more information.

2.1.3 Suppositions on stock structure in adjacent seas.

A number of studies on tuna fisheries and their population structures have recently been made on an ocean-wide basis. The Indonesian waters such as the Banda-Flores Seas have been considered as a boundary area between the Pacific and the Indian Oceans concerning the distribution of the yellowfin tuna in the Indo-Pacific areas. And the distribution of the fish in this boundary area has so far been discussed in relation to those distributed in the eastern Indian Ocean (Nakamura, 1953; Mimura and Nakamura, 1959; Morita and Koto, 1971).

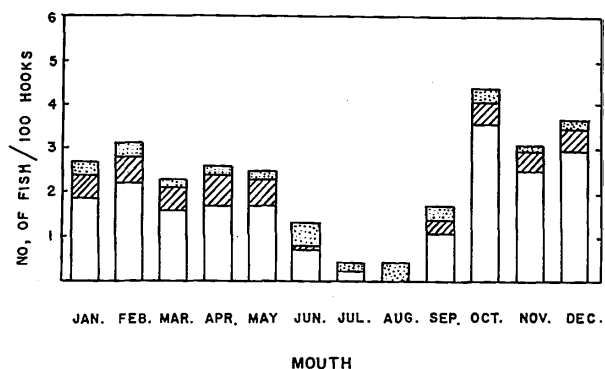

Fig. 3 Seasonal change in the hook-rate in the South China Sea area (Average for the period 1930 - 1956, excluding the years 1942 - 1950) ... (Kikawa, 1959)

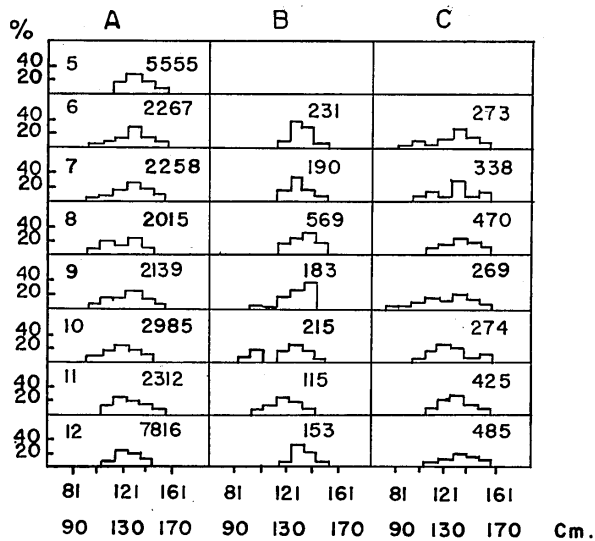

Fig. 4 Body length compositions of yellowfin tuna by month (Data from the monthly report of Taiwan Fisheries Research Institute-1954). (Kikawa and Anraku, 1959)
 A. South China Sea area (North of 10° N)
 B. " (South of 10° N)
 C. Sulu Sea

Concerning the intermingling of the yellowfin tuna between the Pacific and the Indian Oceans, Mimura and Nakamura (1959) assumed that some intermingling of the fish between the western equatorial Pacific and the eastern Indian Ocean might take place through the Banda-Flores Seas but such an intermingling would be of too small a scale to change the abundance of the stocks in these adjoining oceans. In this context, Mimura (1957) reported a notable phenomenon observed in the Japanese Indian Ocean fishery in its earlier stage; it was an immediate and a remarkable decrease in the hook-rate and the size of the fish which occurred in many of the newly exploited fishing grounds. This sudden decrease was considered to be the direct effect of the fishery exploitation on the virgin stock. Analysing the annual fluctuations in the hook-rate and the size of the fish, Mimura and Nakamura (1959) noted that such an effect occurred so that the fish among different fishing grounds appeared to be independent of each other. On the other hand, however, the detailed analyses on the distribution and the fish size indicated a large-scale east-west movement of the fish in the equatorial waters of the Indian Ocean and a large north-south migration in the Bay of Bengal. This absence of agreement in phenomena led them to a conclusion that two or more independent groups of the fish were hardly recognizable in the Indian Ocean but the intermingling was much more active among the fish in adjoining areas and the rate of mixing was less among those in distant localities. The same idea is set forth for the yellowfin tuna in the equatorial Pacific Ocean (Royce, 1965).

The morphometric comparisons also suggested the existence of some semi-independent subpopulations within the Indian Ocean (Kurogane and Hiyama, 1958; Kurogane, 1960). In this analysis, it was noted that the fish

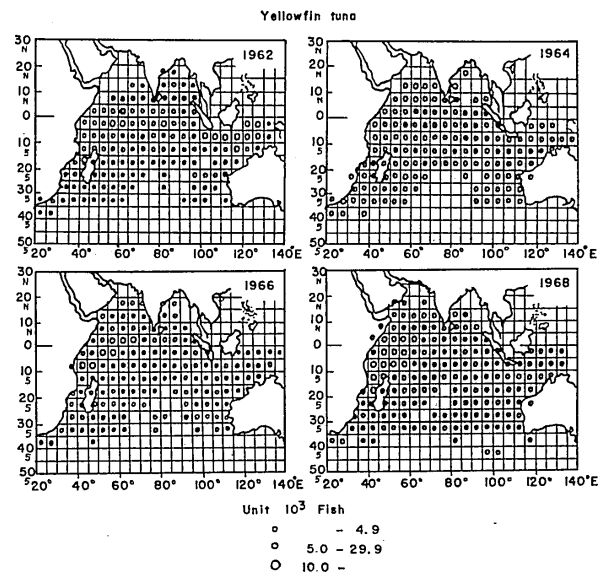

Fig. 5 Distribution of yellowfin tuna catch by Japanese longline fishery in the Indian Ocean, 1962, 1964, 1966 and 1968 (Honma and Suzuki, 1972).

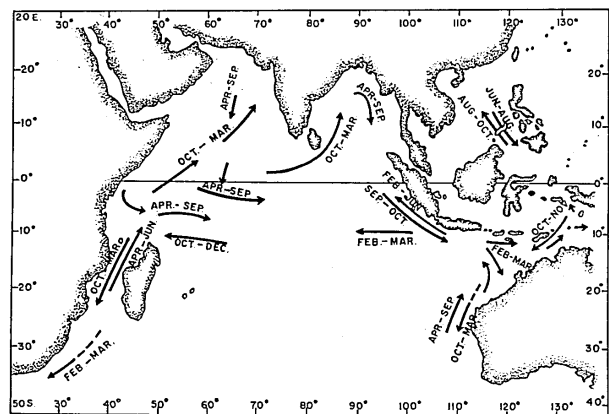

Fig. 6 Supposed movements of yellowfin tuna in the Indian Ocean and adjacent areas, as speculated on the changes in the hook-rate and the size of the fish (Honma, unpublished)

in the areas from the eastern Indian Ocean to the south of Java appeared to be separable from those in the central and western equatorial areas of the Indian Ocean, although some intermingling of the fish was assumed.

More recent analysis on the seasonal and regional changes in the yellowfin tuna concentrations suggest the occurrence of two separable migratory groups, one in the western Indian Ocean and the other in the Banda-Flores Seas. The apparent boundary between the areas of these two fish concentrations occurs at approximately 100° E. longitude (Morita and Koto, 1971). Such a pattern of the fish concentrations is suggested in Figure 5.

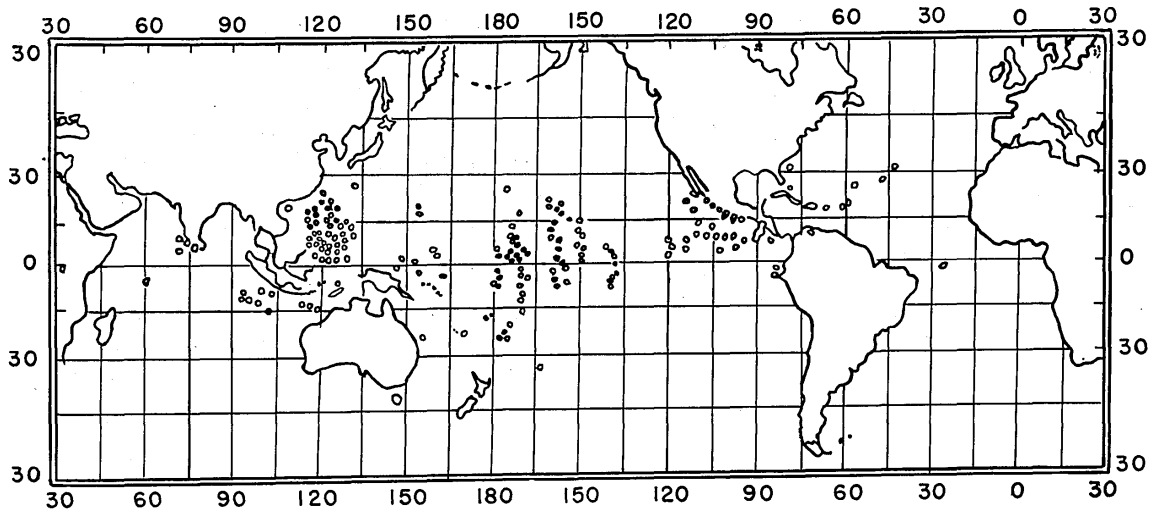

Fig. 7 Localities of capture of larval yellowfin tuna (Yabe et al., 1963).

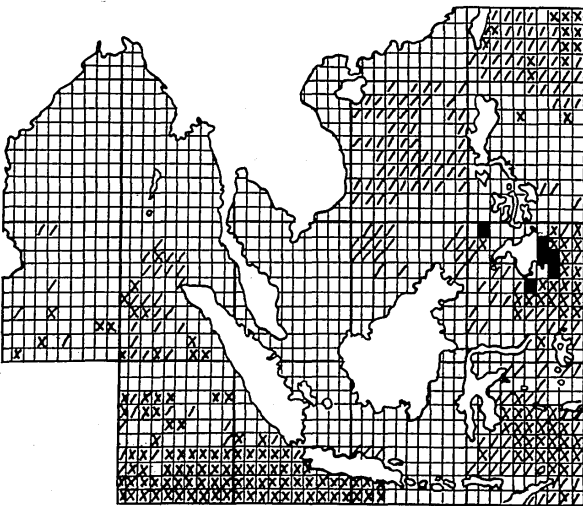
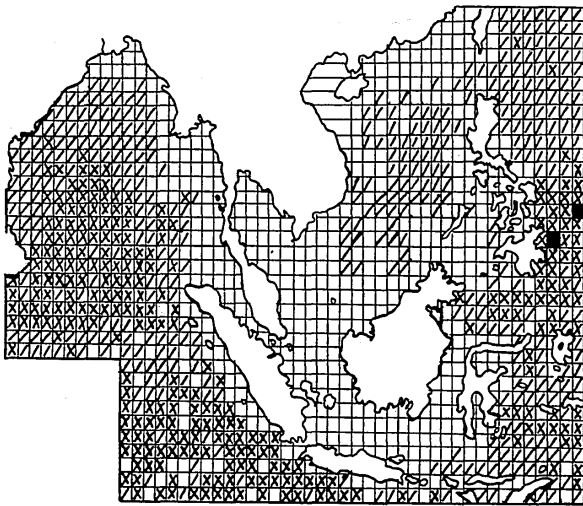

Fig. 8 Distribution of bigeye tuna.
Upper, April-June.
Lower, October-December.

Figure 6 shows the supposed movements of the yellowfin tuna in the Indian Ocean and adjacent seas, which were assumed in the light of these suppositions (Honma, unpublished). In this figure, it is suggested that the yellowfin tuna in the South China Sea have a higher relationship with the fish in the Sulu, Celebes, Banda and Flores Seas or in the western equatorial Pacific than with those in the northern areas to the east of Balintang Channel.

Figure 7 shows the distribution of the larvae of the yellowfin tuna around the Philippines. Such a larval distribution appears to support a view of the strong mixing of the fish in Philippine waters.

From the foregoing, if the intermingling exists for the yellowfin tuna in the South China Sea, it would possibly cause the significant change in abundance of the stock in this area.

2.2 Bigeye tuna

2.2.1 Distribution and seasonal change in hook-rate.

Bigeye tuna rank next to yellowfin tuna in abundance in the South China Sea and adjacent waters.

The distribution of areas of the apparent relative abundance is shown as Figure 8. The average hook-rate of bigeye tuna was about one third or one fourth of yellowfin tuna on the past data from 1952 to 1961. The catches of this fish have increased gradually in recent years.

The hook-rate is also subject to a large seasonal change (Figure 3). The months of the lowest hook-rated are July and August, the southwest monsoon season, as with yellowfin tuna.

2.2.2 Size composition

The size of the fish caught in the South China Sea, according to a small number of data obtained from the longline fishery in 1953–1955, ranged from 100 to 170 cm in length, but was mostly between 120 and 150 cm. Figure 9 shows the size composition in the Banda-Flores Seas. The size of the fish nearly resembles that in the South China Sea but in this Indonesian area smaller fish were relatively abundant in the early half of the year (Mimura and Nakamura, 1959).

2.2.3 Suppositions on stock structure in adjacent seas.

From the morphometric comparisons of some body characters, it was found that the differences between the fish in the south of Java and the central and western equatorial Indian Ocean were larger than the differences among those distributed throughout this equatorial belt of waters (Hiyama and Kurogane, 1961). Analyzing the distribution of the bigeye tuna in the Indian Ocean, Kume and others (1971) assume that the fish in this ocean are composed of groups of fish which are highly related with each other throughout their life history. Concerning the intermingling of fish between the western Pacific and the eastern Indian Ocean, some possible intermingling through the Banda-Flores Seas is also assumed (Kume et al., 1971).

2.3 Albacore and bluefin tuna

Unlike the tropical tuna, the albacore are sparsely distributed in the South China Sea, as indicated in Figure

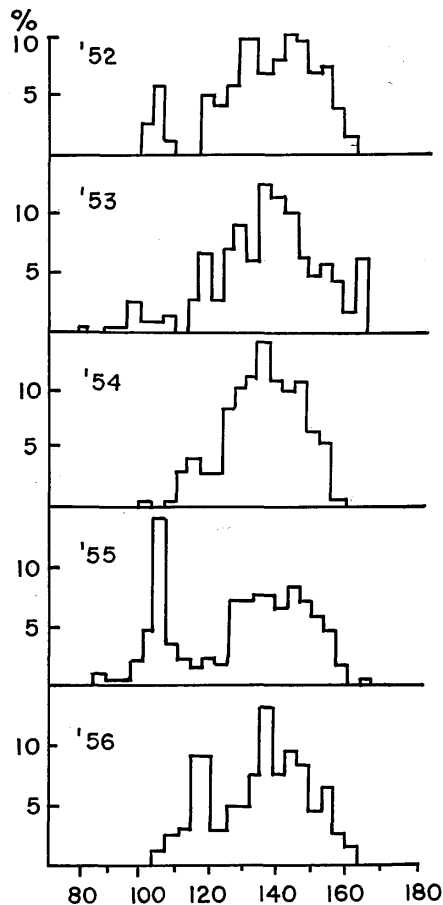

Fig. 9 Length frequency distributions of bigeye tuna taken by the longline fishery in the Banda-Flores Seas (Minura and Nakamura, 1959).

10. The fish occurring in this area are probably related to the North Pacific albacore, not to the fish in the eastern Indian Ocean. Their economic value as a fishery resource is low in this area.

Bluefin tuna rarely occur in Japanese longline catches but they are important for small vessels based on Kiohsung, Taiwan. The fish are known to be distributed in the South China Sea north of approximately 16° N. latitude. Formerly, the fishing grounds were restricted to the region west of the Bashi Channel but they gradually expanded to the area off the east coast of Luzon (Nakamura, 1953). The season of the best fishing is April and May. For bluefin tuna in the western North Pacific, it is known that spawning takes place from near Taiwan to the south of southern Japan in May and June and the hatched larvae are collected in the same area. The juvenile fish, 15 cm long or more, are caught by coastal trolling off southern Japan after July. The fish after spawning also migrate to the north. The results of tagging experiments and analyses on size data strongly suggest that the bluefin tuna in the western Pacific and those in the Californian waters belong to the same population. Therefore, the South China Sea area is the westernmost fraction of the area of the distribution for the North Pacific bluefin tuna.

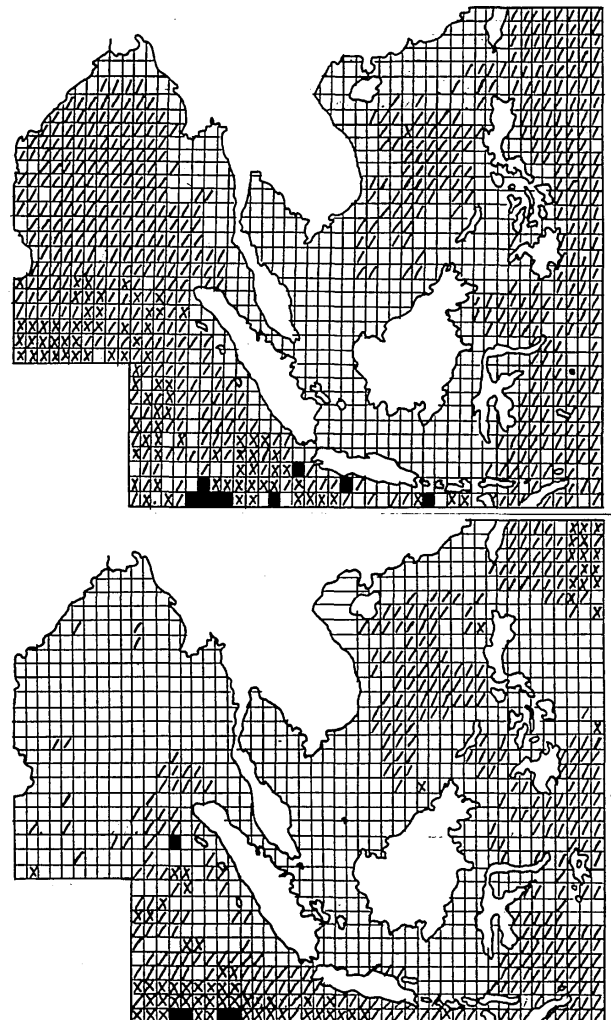

Fig. 10 Distribution of albacore. Upper, April–June. Lower, October–December.

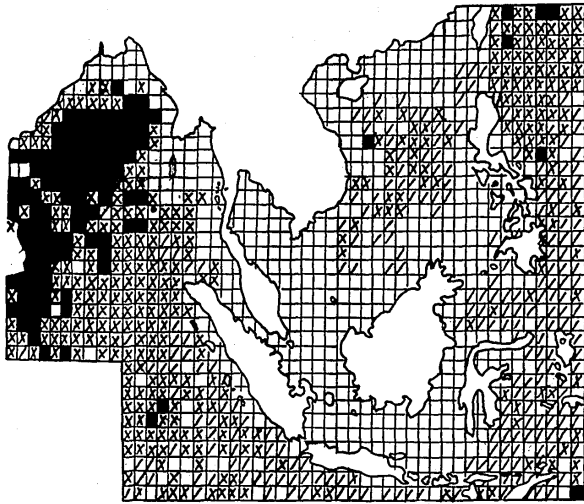

Fig. 11 Distribution of striped marlin.
Upper, April-June.
Lower, October-December.
Black, cross and oblique line indicate areas with hook-rate of 0.5 and greater, 0.1-0.4 and 0.0, respectively.

2.4 Billfishes

Generally, the billfishes are more sparsely distributed than the tropical tuna in the South China Sea.

Figure 11 has been prepared for the striped marlin and shows markedly less value of the hook-rate than in the case of tunas. The areas of relatively high hook-rate occur in the western half of the Bay of Bengal in April - June. In the South China Sea, only a small number of such areas are found in the central part and also in the Sulu and Celebes Seas and the eastern seas of Taiwan in October-December.

For blue marlin, as shown in Figure 12, the area of relatively high fish concentrations also occur outside the South China Sea, that is, in the western equatorial area of the Indian Ocean from the Bay of Bengal region to the south of Java and the eastern seas of the Philippines. However, the blue marlin was the most important item in the South China Sea fishery based on Kaohsiung (Nakamura, 1953) and even today occurs most frequently

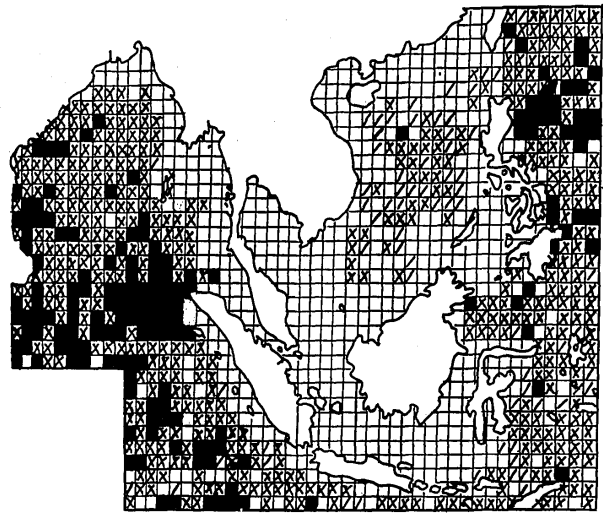

Fig. 12 Distribution of blue marlin.
Upper, April-June.
Lower, October-December.

in the Japanese longline catches among billfish.

Black marlin are fish of the continental shelf waters and possibly important in this area. In Japanese catches, they are comparable with blue marlin in quantity.

Sailfish rarely occur in Japanese catches in this area but they are the most important in quantity among billfish for the Taiwanese fleets. This difference may probably be dependent on the difference in the construction of the longline gear.

3. RECENT TREND IN LONGLINE CATCHES

Table 1 shows the estimated catches by species made by the Japanese longline fishery in the South China Sea area from 1960 to 1971. The Japanese catches from this area as specified in Figure 1 have ranged from 200 tons to 6,800 tons during the past 12 years. The largest catches were attained in 1967 and since then the longline catches have fluctuated between 2,000 and 5,000 tons with a somewhat downward trend. Taiwanese data for the same estimation are not available for this period. According to the 1966 statistics, the total landings by the Taiwanese

Table 1. Estimated catches (M/T) by species made by Japanese longline fishery in the South China Sea area (1960 – 1971).

Year	YF	BE	AL	SM	BM	BKM	SF-SS	SJ	Total
1960	160	38	0	1	8	4	0	0	211
1961	1,325	270	0	10	32	29	1	0	1,668
1962	1,257	444	6	11	46	45	12	0	1,821
1963	1,429	369	6	17	51	45	7	0	1,925
1964	682	165	4	6	30	26	2	0	916
1965	1,796	495	7	11	82	55	5	2	2,452
1966	1,360	542	0	5	54	41	7	1	2,012
1967	4,661	1,817	8	35	206	103	18	1	6,848
1968	2,586	985	1	18	109	78	8	0	3,786
1969	3,100	1,434	4	16	73	79	9	1	4,728
1970	1,454	745	1	6	43	53	3	0	2,304
1971	2,038	1,000	0	11	56	60	4	0	3,169

Data are based on the "Annual report of effort and catch statistics by area on Japanese tuna longline fishery, 1962 – 1971" (Research Division, Fisheries Agency of Japan) and unpublished data, 1960 and 1961.

Catch by species was estimated by multiplying the average weight of fish in this area by the total estimated number of the fish.

YF, Yellowfin; BE, Bigeye; AL, Albacore; SM, Striped marlin; BM, Blue marlin; BKM, Black marlin; SF-SS, Sailfish and Shortbill spearfish combined; SJ, Skipjack.

fleets from the South China Sea area are roughly estimated to be 2,500 tons. So, the estimated total catches by the Japanese and Taiwanese fisheries in recent years may be between about 5,000 and 8,000 tons annually. The largest catches are of yellowfin tuna. The proportion of bigeye tuna has increased recently to about a half of that of yellowfin tuna. Ninety percent of the total catches or more is held by these two species in the case of the Japanese longline fishery. For the Taiwanese catches, 30 per cent or more may be occupied by billfish, mostly sailfish. Figure 13 shows the trend of yellowfin and bigeye tuna catches in the South China Sea.

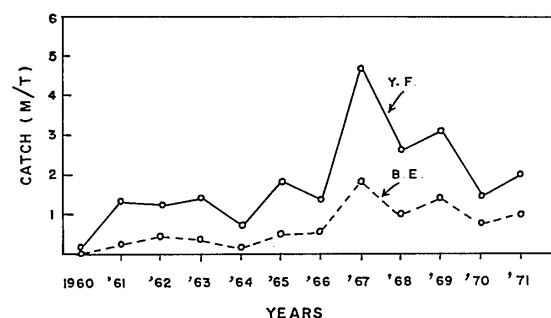

Fig. 13 Catches of yellowfin and bigeye tuna by the Japanese longline fishery in the South China Sea area.

Table 2. Estimated catches (M/T) by species made by Japanese longline fishery in the Southeast Asian waters (1960 – 1971)

Year	YF	BE	AL	SM	BM	BKM	SF-SS	SJ	Total
1960	7,791	3,463	239	276	1,030	606	244	4	13,653
1961	5,856	3,638	487	565	632	377	169	1	11,725
1962	15,564	6,743	372	364	1,148	1,295	631	9	26,124
1963	7,359	4,145	580	389	623	620	961	5	14,632
1964	6,522	4,480	524	137	912	1,010	230	3	13,818
1965	9,147	5,604	581	634	1,226	771	290	23	18,277
1966	7,361	4,041	475	163	608	688	167	19	13,523
1967	9,748	6,044	317	496	955	825	304	14	18,702
1968	7,547	4,471	391	101	618	1,103	279	15	14,525
1969	7,863	4,402	226	183	648	468	147	16	13,953
1970	5,198	3,262	187	167	360	334	73	27	9,607
1971	4,352	2,377	68	126	325	399	118	10	7,774

Data are based on the "Annual report of effort and catch statistics by area on Japanese tuna longline fishery, 1962 – 1971" (Research Division, Fisheries Agency of Japan) and unpublished data, 1960 and 1961.

Catch by species was estimated by multiplying the average weight of fish in this area by the total estimated number of the fish.

YF, Yellowfin; BE, Bigeye; AL, Albacore; SM, Striped marlin; BM, Blue marlin; BKM, Black marlin; SF-SS, Sailfish and Shortbill spearfish combined; SJ, Skipjack.

Table 2 shows Japanese longline catches in the Southeast Asian waters as defined in Figure 1. Total estimated catches for the past 12 years have varied between 7,000 and 27,000 tons with a remarkable drop in the last two years.

Such trends as mentioned above are shown in Figure 14. For Southeast Asian waters, yellowfin and bigeye tuna are the major products of the longline fishery but it should be remembered that this area only represents a part of the ocean where the stocks of these tunas are maintained. As seen in the figure, the recent decrease in number of fishing vessels. It probably reflects the growing interest of the fishermen in southern bluefin tuna which, in turn, has resulted in the removal of some proportion of fishing effort out of the eastern equatorial Indian Ocean. Such a removal of fishing effort from the Southeast Asian waters seems to be indicated in Figures 15 and 16.

4. SMALL-SIZED TUNA AND TUNA-LIKE FISH

The stocks of the large-sized tuna have been heavily fished in every ocean but the world demand for tuna is still growing. In this situation, a great deal of interest has recently been directed to small-sized tuna and tuna-like fish. Most of these fish are coastal in habitat or dwellers in continental shelf waters from the tropical to the temperate zones.

According to RAO fisheries statistics, catches of various tuna-like fishes in the Southeast Asian countries were 100,000 – 150,000 tons in recent years. Of these, 40,000 – 60,000 tons were taken by the Philippines and Malaysia in the South China Sea.

The catches appearing on the statistics probably comprise many different species. These various fishes may include the skipjack (*Euthynnus pelamis*), little tuna (*E. affinis*) longtail tuna (*Thunnus tonggol*), frigate mackerel (*Auxis thazard* and *A. rochei*), bonito (*Sarda orientalis*), spanish mackerel (*Scomberomorus spp.*) and sometime even the young form of the yellowfin tuna. These small-sized tuna and tuna-like fish are caught by various local fisheries in countries surrounding the South China Sea but they, as a whole, seem to be quite under-exploited.

Figure 17 shows the distribution of skipjack as seen from commercial longline data. Like large-sized tuna, skipjack are distributed widely in the world oceans between about 40° N. and S. latitudes and, among small-sized tuna, they are the only fish supporting the large-scale commercial fisheries. In the Pacific Ocean, they are mostly caught by the Japanese live-bait fishery in the western part and by the American purse-seine fleets in the eastern equatorial areas.

This size composition of the fish based on data from different sources are shown in Figures 18 – 20.

In the South China Sea, skipjack are caught by trolling or other coastal fisheries in the Philippines. The fish taken by trolling are mainly from 40 to 60 cm in length. The size range is almost identical with the size of fish caught by the Japanese live-bait fishery. According to Ronquillo (1963), skipjack are known to breed during the greater part of the year in Philippine waters.

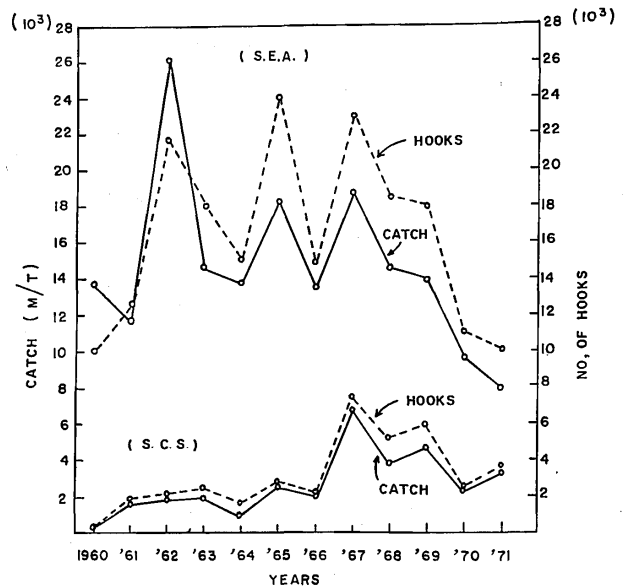

Fig. 14 Total catches and effort by the Japanese longline fishery in the South China Sea area and the Southeast Asian waters.

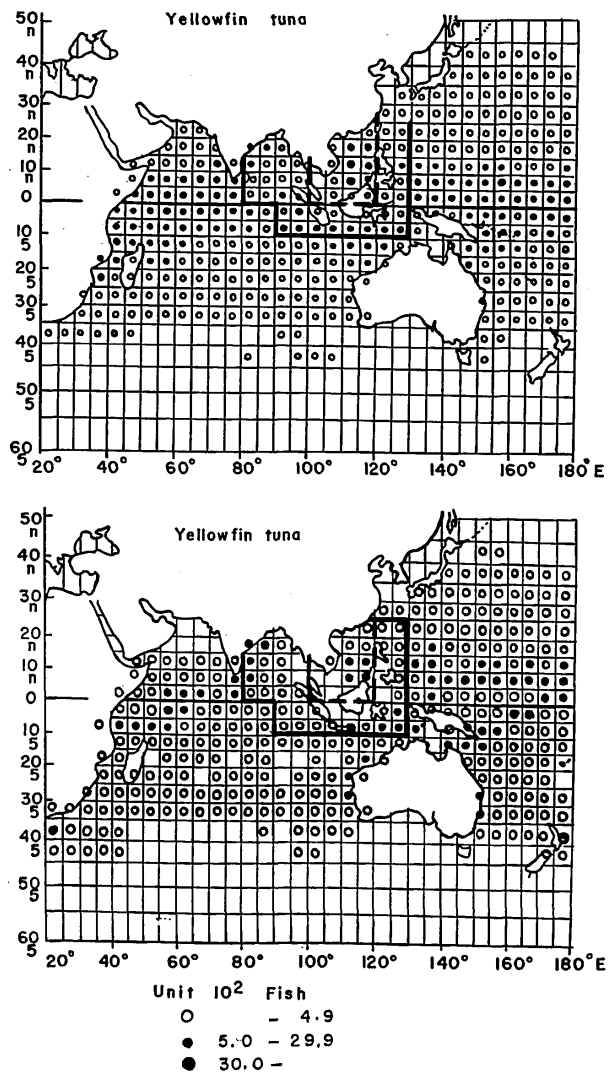

Fig. 15 Distribution of yellowfin catch in number.

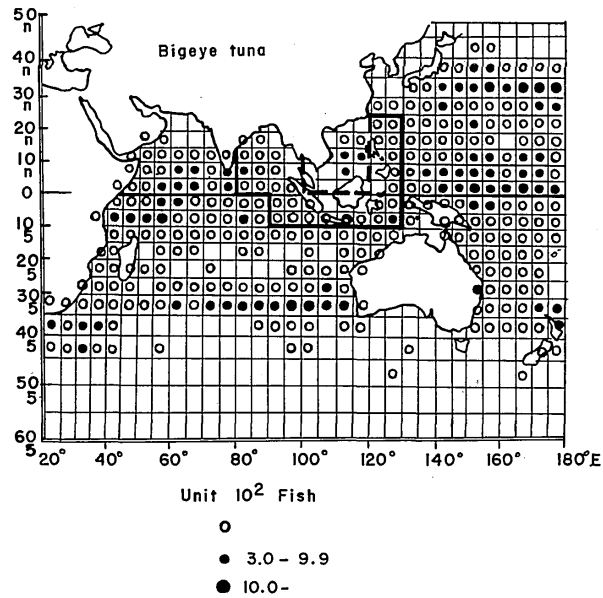
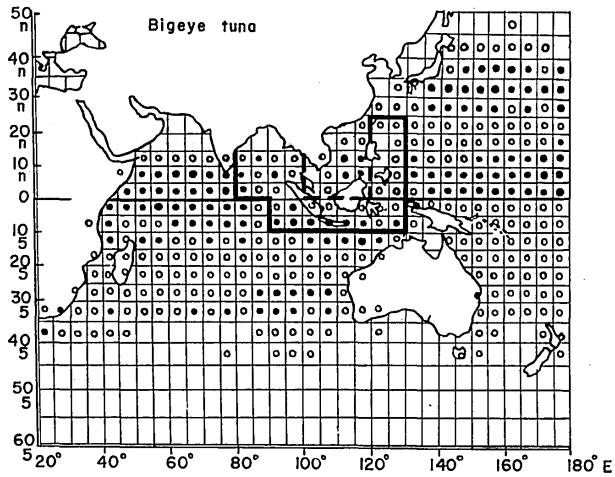

Fig. 16 Distribution of bigeye catch in number.

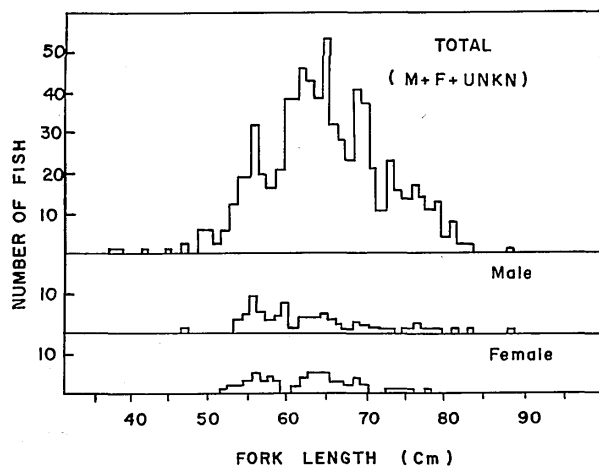

Fig. 18 Size composition of skipjack caught by long-line for all areas, seasons and year combined (Miyake, 1968).

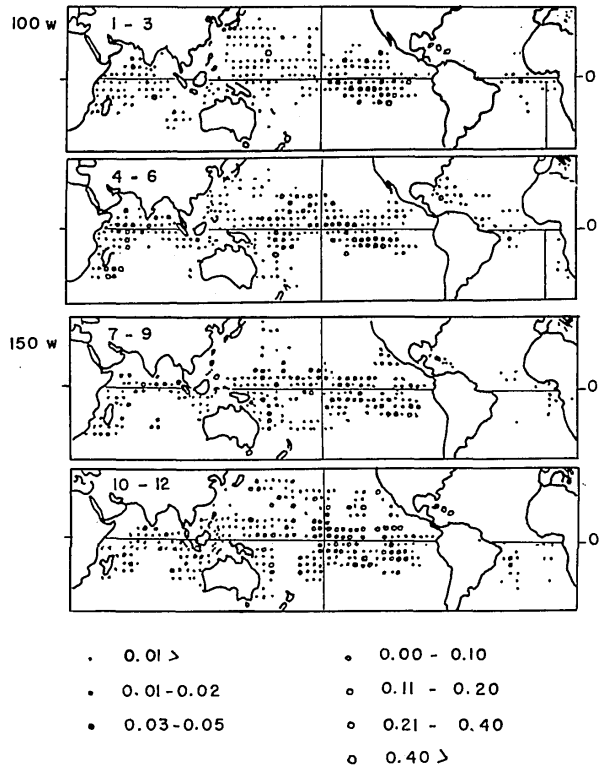

Fig. 17 Geographical distribution of skipjack tuna based on the hooking-rate of Japanese long-line catch in 1965 (Kasahara, 1968).

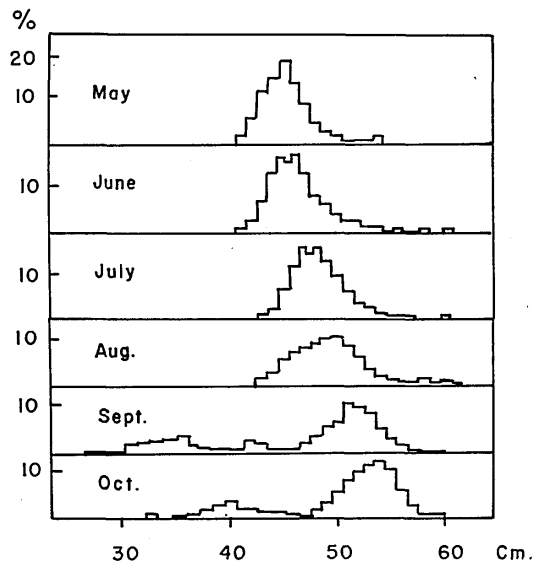

Fig. 19 Average monthly frequency distribution of skipjack tuna caught by the Japanese live-bait fishery in the northeastern offshore area of Japan, 1951-1955 (Kawasaki, 1964).

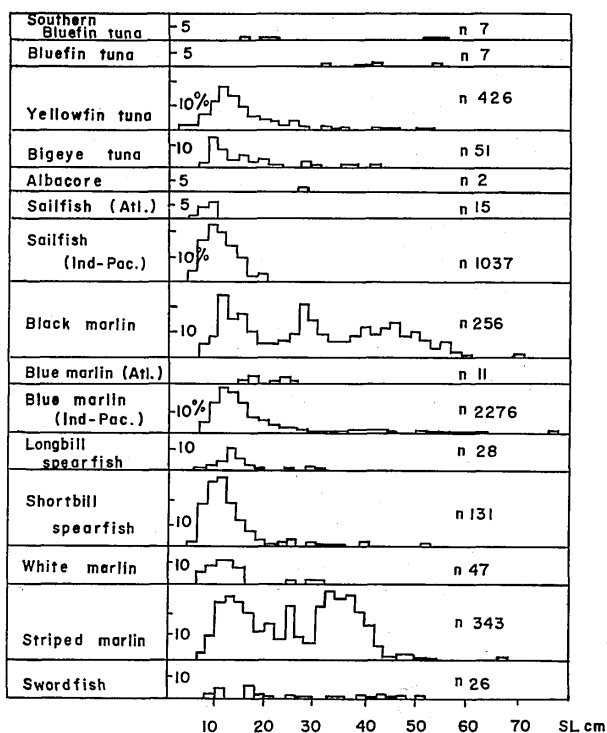

Fig. 20 Length frequency distribution of skipjack found in the stomachs of predatory species. All areas, seasons and years combined. (Mori, 1972).

The little tuna are very widely distributed in the continental shelf waters and around the islands in the Southeast Asian waters, as suggested in Figure 21. The fish are also known to spawn nearly throughout the year in Philippine waters (Ronquillo, 1963). In this area, the fish taken by trolling range in length from 30 to 70 cm, mostly between 40 and 60 cm. In the Hong Kong area, little tuna are caught in the modified purse-seine set close to the gulch. Catches are mostly made during June to August. Fish from 30 to 70 cm in length occur in catches but during the fishing season, June-August, larger fish above 50 cm predominate (Williamson, 1970).

Frigate mackerel also occur in catches in the Hong Kong area (Williamson, 1970). In the Indian Ocean, they are the seasonal visitors to the coastal waters and usually caught in shore seine, drift nets and by trolling (Jones and Silas, 1963).

For longtail tuna, exact information on their occurrence in the South China Sea is not available. However, since their distribution ranges from the east coast of Africa to the Southeast Asian waters (Jones and Silas, 1963), it is likely that they are distributed widely in the continental shelf waters around the South China Sea.

REFERENCES

- FAO, 1971. Catches and landings, 1970. YB. Fishery Statist., (30): XXII: 476 p.
- Gulland, J. A. (Comp.) (Ed.), 1970. The fish resources of the oceans. FAO Fish. Tech. Pap., (97): 425 p.

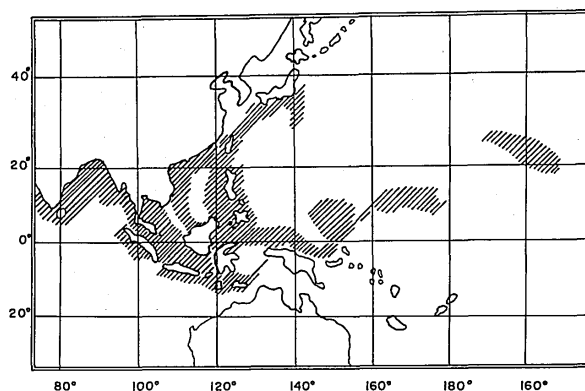

Fig. 21 Distribution of little tuna, *Euthynnus affinis* (Williamson, 1970).

- Hiyama, Y. and K. Kurogane (MS), 1961. Morphometrical comparisons of tuna from areas in the Pacific and Indian Oceans. Presented at the Pacific Tuna Biol. Conf., Honolulu, 1961, Paper No. III-7; 1-7.
- Jones, S. and E. G. Silas, 1963. Tuna and tuna-like fishes from the Indian seas. FAO Fish. Rep., (6), vol. 3: 1775-1796.
- Kasahara, K., 1968. Present and future prospects of skipjack fisheries. Bull. Jap. Soc. Fish. Oceanogr., 13: 127-132.
- Kikawa, S. and N. Anraku, 1959. Fishing grounds in the South China Sea. Average year's fishing conditions of tuna longline fisheries, 1958 Edition: 252-262.
- Kume, S., Y. Morita and T. Ogi, 1971. Stock structure of the Indian bigeye tuna, *Thunnus obesus* (Lowe), on the basis of distribution, size composition and sexual maturity. Bull. Far Seas Fish. Res. Lab., 4: 141-164.
- Kurogane, K. AND Y. Hiyama, 1958. Morphometric comparison of the yellowfin tuna from six grounds in the Indian Ocean. Bull. Jap. Soc. Sci. Fish, 24 (6& 7): 487-494.
- Kurogane, K., 1960. Morphometric comparison of the yellowfin tuna from the Banda Sea and its adjacent waters. Rec. Oceanogr. Works Jap., 5(2): 105-119.
- Mimura, K., 1957. Length frequency of bigeye tuna, caught from the Indo-Australian Archipelago area. Rep. Nankai Reg. Fish. Res. Lab., 6:77-83.
- Mimura, K. and H. Nakamura, 1959. Tuna fishing grounds in the Indian Ocean and its adjacent seas. Average year's fishing conditions of tuna longline fisheries, 1958 Edition: 353-414.
- Miyake, M. P., 1968. Distribution of skipjack in the Pacific Ocean, based on records of incidental catches by the Japanese longline tuna fishery. Bull. Inter-Amer. Trop. Tuna Comm. 12(7): 5111-608
- Mori, K., 1972. Geographical distribution and relative abundance of some Scombroid fishes based on their occurrence in the stomachs of apex predators caught on longline - I, Juveniles and young of skipjack tuna (*Katsuwonus pilamis*). Bull. Far Seas Fish. Res. Lab., 6: 111-168.
- Morita, Y. and T. Koto, 1971. Some consideration on the population structure of yellowfin tuna in the Indian Ocean based on the longline fishery data. Bull. Far Seas

- Fish. Res. Lab., 4: 125-140.
- Nakamura, H. 1953. A review of the fishing grounds of tuna long-line based on past data. Rept. Nankai Reg. Fish. Res. Lab., 1(2nd Ed.): 1-144.
- Research Division, Fisheries Agency of Japan, 1965-1973. Annual report of effort and catch statistics by area on Japanese tuna longline fishery, 1962-1971 Editions.
- Ronquillo, I. A., 1963. A consideration of the biology of Philippine tunas. FAO Fish. Rep., (62), vol. 3: 1683-1752.
- Royce, W., 1965. A morphometric study of yellowfin tuna *Thunnus albacares* (Bonnterre). Fish. Bull., U.S. Fish Wildl. Serv., 63(2): 395-443.
- Suda, A., 1971. Tuna fisheries and their resources in the IPFC area. Far Seas Fish. Res. Lab., S Series, 5: 1-58.
- Ueyanagi, S. 1969. Observation on the distribution of tuna larvae in the Indo-Pacific Ocean with emphasis on the delineation of the spawning areas of albacore, *Thunnus alalunga*. Bull. Far Seas Fish. Res. Lab., 2: 177-256.
- Williamson, G. R., 1970. Little tuna *Euthynnus affinis* in the Hong Kong area. Bull. Jap. Soc. Sci. Fish., 36 (1): 9-18.
- Wyrcki, K., 1961. Scientific results of marine investigation of the South China Sea and Gulf of Thailand, 1959-1961. Naga Rep., (2): 195 p.
- Yabe, H., Y. Yabuta and S. Ueyanagi, 1963. Comparative distribution of eggs, larvae and adults in relation to biotic and abiotic environmental factors. FAO Fish. Rep., (6), vol.3: 979-1009.
- Yabe, H., S. Ueyanagi and H. Watanabe, 1966. Studies on the early life history of bluefin tuna *Thunnus thynnus* and on the larva of the outhern bluefin tuna *T. maccoyii*. Rept. Nankai Reg. Fish. Res. Lab., 23: 95-129.

SEAFDEC/SCS.73: S-29

Some Considerations of Research and Study on Pelagic Fishery Resources

by

Kenji Kurogane
Tokai Regional Fisheries Research Laboratory
Tokyo; Japan

Abstract

The approach to the stock assessment and fishery management is briefly described on the Indo-Pacific mackerel resource in the Gulf of Thailand and the yellowtail resource around the Pacific coast of Japan.

Recently, the fishery forecast has become one of the great concerns of Japanese researchers working on the pelagic fisheries. In addition to information concerning the stock assessment, knowledge on fish movements and aggregations connected with environmental conditions is accumulated to secure a correct forecast of fishery.

In spite of strenuous efforts of researchers, pelagic fishery such as natural fluctuation in fish abundance and catch, widely ranging movement and distribution and diversity of fishing gear etc., bring about many difficulties and problems on the stock assessment, fishery management and forecast. At present, the results of studies are not always so reliable to satisfy the fishermen. Researchers, however, are endeavouring step by step to ensure correct and timely judgements on the above objects of fishery science with more intensive communication with fishermen.

1. INTRODUCTION

The landings of some commercially important pelagic fish in Japan, such as sardine, anchovy, herring, saury pike, common mackerel and horse mackerel, have fluctuated considerably in past years as shown in Fig. 1.

Details of these fluctuations were described for each resource by Uda at 15th Session of IPFC. Such fluctuation characters in catches of pelagic stocks have been recognized not only by fishermen but also by many researchers working on fishery resources.

These landings are affected by many factors, such as the strength of fishing efforts, the availability of fish stock in the fishing grounds, the stock abundance and so on. However, it may be said that fluctuation patterns in landings of these pelagic fish for a long period are almost similar to the ones in stock abundances.

In fishery science, one of the important works is to carry out the stock assessment, using the catch statistics, biological information and so on. According to a result of stock assessment, some stocks may be more heavily exploited and others may have to be managed by fisheries regulations in order to secure the full and optimum utilization of the resources.

For some pelagic stocks, researchers' efforts are centered to get the information on the abundance of offspring and recruitment, migratory and distributional patterns of fish by developmental stage, local movement and aggregation of fish schools in the fishing grounds connected with oceanographic conditions. Based on above information and stock assessment, works of forecasting on the fish catch, size, time and area of formation of fishing grounds for the coming season, have been conducted recently.

2. STOCK ASSESSMENT AND MANAGEMENT OF PELAGIC RESOURCES

In spite of the fluctuation characters of pelagic resources, stock assessment and fishery management are not dispensable for the full and rational utilization of these resources, as pointed out by Gulland at the 15th Session of IPFC.

The way to approach to the stock assessment is described in detail in the FAO "Manual of methods for fish stock assessment. Part 1. Fish population analysis" (J. A. Gulland, 1969). Based on the materials of catch statistics, biological surveys and tagging experiments, at first basic population parameters on growth, natural and fishing mortality, and age at recruitment etc. are estimated for each resource. Then using these estimates, the state of stock is evaluated by yield model etc. Sometimes, as seen in analyses of salmon and whale stocks, reproductive relation between the abundance of parents and succeeding recruitments are induced in the stock assessment.

A typical example of research works of pelagic resources seems to be indicated in "Mackerel Investigations Programme" in Thailand. Namely, the Government of Thailand launched a programme of mackerel investigation since 1956 with the aim of stabilizing resources and assuring their maximum sustainable yield. Surveys and studies in the programme are as follows:

- 1) Catch statistics of mackerel;
- 2) Size compositions of mackerel;
- 3) Tagging experiments;
- 4) Study of early life history;
- 5) Racial study.

Based on these materials and studies, the present state of Indo-Pacific mackerel (*Rastrelliger neglectus*) resource is evaluated by Kurogane et al. (1970) and Hongskul (1972). The flowchart of stock assessment procedures on the mackerel by Kurogane et al. is shown in Fig. 2. Results of these surveys and studies have been reported in a number of publications issued by the Marine Fisheries Laboratory in Bangkok, and in the Proceeding of IPFC, and recently summarized by Dhebtaranon and Chotiya-putta (1972). According to this paper, a plan of management of mackerel fishery in the Gulf of Thailand, namely, limiting the number of boats, gear, mesh size, fishing in spawning season and area, was offered by the Pelagic Fisheries Investigation Unit of the Marine Fisheries Laboratory to the Department of Fisheries.

Stock assessments and fishery managements, similar to the above case, are seen in the studies of tunas, common mackerel and yellowtail resources etc. in Japan. As to yellowtail (*Seriola quinqueradiata* T. & S.) around the Pacific coast of Japan, for instance, the fishing is largely changing of late. As one example, the catch of adult yellowtail by the set nets is declining, but that of immature ones by the purse seines and lines is on the increase. Recently, the production of cultured yellowtail is rapidly going up, as the juveniles are caught in a large amount at sea. It is assumed that the capture of juvenile yellowtail for culture affects approximately 10% on the fish resources. It is also considered that an augmentation of fishing intensity of the purse seines for immature

yellowtail decreases to 2/3 of the adult resources. But the total catch of the fish does not fluctuate. The only problem is allocation of the fish catch by various fishing methods.

As one of the results of yellowtail stock assessments, the schematic diagram on life cycle of yellowtail is obtained with estimates of population parameters. At present, the fishing of juvenile yellowtail for culture has many limitations in the number of boats, amount of fish caught, and fishing period etc.

3. CHARACTERS OF PELAGIC RESOURCES AND FISHERY FORECAST

Rounsefell and Everhart (1953) pointed out that herring is a good example of a species subject to great natural fluctuations in abundance, and fluctuations of this type appear to be caused by great differences from year to year in the survival of young.

Many researchers indicated that the critical depletion in the catches of the Japanese sardine resource since 1941 was attributed to scarcity of recruitment from the 1938 to 1941 year classes, and effects of such factors as fishing, predatory mortality and changes in the availability were ruled out from the major causes (Kurita, 1960).

Judging from these and other cases, we can easily recognize that some resources of pelagic fish have a fluctuating and unstable character in abundance, that is caused mainly by natural factors.

In addition to this character, generally speaking, they tend to migrate widely in the sea and to be caught by various types of fishing gear. Accordingly, it seems to be considerably difficult to get the precise and reliable estimates of population parameters on the mortality and abundance, as pointed out by Gulland at the 15th Session of IPFC.

So, many researchers working on the pelagic fish, as well as fishermen, have much concerns about the forecast of the pelagic fishery, especially short life-span fish resources, for the coming fishing season.

Uda (1972) referred to the relation between the natural fluctuation in the abundance of several pelagic fish stocks in Japan and the oceanographic conditions, and stressed the importance of study of fishery oceanography.

On the common mackerel resource in Japan, Kurogane (1972) showed main results of studies on the stock assessment. At the same time, many researches are carried out to obtain the following ecological information.

- 1) Abundance and distribution of eggs and larvae in the spawning ground (Fig. 4)
- 2) Migratory and distributional patterns of mackerel by developmental stages and yearly cycle of life (such as feeding, wintering and spawning in adult stage)
- 3) Distributional map of relative abundance of mackerel in fishing grounds based on fishermen's operation records.
- 4) Relationship between fish movement, aggregation and environmental conditions including biological, oceanographical and meteorological factors etc.

Kondo (1972) described in detail the above approach

to the resource of Japanese anchovy.

Incorporating the above ecological and fishery information, stock assessment, research vessels' surveys on the abundance of the fish and oceanographical conditions in fishing grounds, and fishermen's operation records, fishery forecast on the fish abundance and catch, size, time and area of formation of fishing ground etc., is conducted several times before and during a fishing season by governmental and prefectural researchers. These forecast contents are speedily communicated to fishermen by means of newspapers, radio, telegram and so on.

Mathematical and statistical approaches to fishery forecast are applied sometimes for some pelagic fisheries. For example, fluctuations of yellowtail abundance or catch are analyzed by the following methods (Doi, 1967; Kawai, 1969; Watanabe, 1965):

- 1) Time series analysis for long-term catch statistics;
- 2) Correlation analysis for catch statistics in several fishing grounds;
- 3) Multivariate analysis or computer simulation for catch statistics, estimated fish abundance and oceanographic conditions, such as water temperature, speed and direction of the Kuroshio Current etc..

In spite of strenuous efforts of research, the results of fishery forecasts are not so reliable to satisfy the fishermen at present, because of insufficiency of analyses of complexity of mechanism of fish movements and aggregations and of difficulty of prediction of the oceanographic conditions.

However, through the forecast activity, the cooperation between researchers and fishermen becomes better and researchers obtain more plentiful and reliable information on the fishing operations and endeavour to improve the way of forecasting. Consequently, for successful operations, fishermen would timely make use of the forecast information and the present conditions of fishing grounds and catches.

At present analysis of pelagic fisheries has many problems for the future from the viewpoint of stock assessment, fishery management and forecast. Researchers, however, have to make efforts to ensure correct and timely judgements on the above objects of fishery science with more close communications with fishermen.

References

- Dhebtaranon, Y. and Chotiyaputta, K. 1972. Review of the mackerel fishery (*Rastrelliger* spp.) in the Gulf of Thailand. A paper submitted to the 15th Session, IPFC.
- Doi, T. 1967. Simulation on fluctuation of abundance of juvenile yellowtail population – I. Preliminary model of fluctuation in Hyuga-nada sea. Bull. Tokai Reg. Fish. Res. Lab., 51.
- Gulland, J. A. 1972. Some considerations of management problems in relation to pelagic fisheries of the IPFC area. A paper submitted to the 15th Session, IPFC.
- , 1969. Manual of methods for fish stock assessment Part 1. Fish population analysis, FAO Manual in Fisheries Science No. 4
- Hongsakul V. 1972. Population dynamics of pla tu *Rastrelliger neglectus* (van Kumpen) in the Gulf of Thailand. A paper submitted to the 15th Session, IPFC.
- Kawai, T. 1969. Analysis of yellowtail abundance caught by set nets in Mie Prefecture. Bull. Tokai Reg. Fish. Res. Lab., 58.
- Kondo, K. 1972. Ecological monograph of the Japanese anchovy, *Engraulis japonica* (Houttuyn) – The perspective, methodology, results and problems for the future. A paper submitted to the 15th Session, IPFC.
- Kurita, S. 1960. Causes of fluctuations in the sardine population off Japan. Proceedings of the FAO Sardine Meeting.
- Kurogane, K. 1972. Review of mackerel resources of the western Pacific. A paper submitted to the 15th Session, IPFC.
- , et al. 1971. On the population dynamics of the Indo-Pacific mackerel (*Rastrelliger neglectus* van Kampen) of the Gulf of Thailand. Bull. Tokai Reg. Fish. Res. Lab., 67.
- Roundsefell, G. A and Everhart, W. H. 1953. Fishery Science. Its methods and applications. John Wilbey & Sons, Inc.
- Watanabe, K. 1965. A few trials using the correlation method to analyze catches of the amber fish, *Seriola quinqueradiata* Temminck et Schlegel, in the Japan Sea. Bull. Jap Sea Reg. Fish. Res. Lab., 14.
- Watanabe, T. 1972. The recent trend in the stock size of the Pacific population of the common mackerel off Honshu, Japan, as viewed from egg abundance. Bull. Jap. Soc. Sci. Fish., 38(5).
- Uda, M. 1972. Fishery oceanography of the western Pacific; Application of oceanographic information to forecast natural fluctuation in the abundance of certain commercially important pelagic fish stocks. A paper submitted to the 15th Session, IPFC.

THE DEMERSAL RESOURCES

SEAFDEC/SCS.73: S-5

A Rational Survey Method for Evaluation of Trawl Fishing Ground

by

Otohiko Suzuki

Marine Fisheries Research Department
Southeast Asian Fisheries Development Center

Abstract

The paper presents a method by which the optimum number of hauls for an area can be estimated when the desired precision for estimating fish abundance is given. This method is applied to an area along the east coast Gulf of Thailand. The area was divided into three subareas according to the various features of fishing conditions. Subarea-I contains 13 blocks and is located in the southernmost part of the area; subarea-II comprises 17 blocks in the northernmost part and extends eastwards in the form of a rectangle. The remaining 31 blocks are contained in the subarea-III which occupy the intermediate and off-shore regions of the two subareas. The superiority of trawl fishing ground is in the order of the subareas II, I and III. If an error of 20% can be tolerated for the estimate of fish abundance, sixty hauls are necessary for subareas I and III, while thirty hauls are sufficient for subarea-II.

Introduction

In an unexploited area evaluation of trawl fishing ground is usually made by an estimation of fish abundance from a limited number of experimental trawls. It may be unavoidable in a preliminary survey that the result is accompanied with some degree of statistical inaccuracy. However, when the area is trawled repeatedly for more detailed survey, careful consideration should be made on planning the research programme.

Generally, even when trawling is repeatedly carried out in the same fishing ground, large variation of catch can still be encountered; and when the sample in a locality is too small, the data are often unreliable for quantitative analysis. In actual experimental trawls, however, it is not easy to obtain a large enough sample per unit area especially when it is also necessary to collect data covering as wide an area as possible. To achieve the dual objectives simultaneously for every cruise would be a problem if research facilities were limited. This paper, therefore, attempts to settle the difficulty by compromising between statistical accuracy and available facilities.

The present problem should be reduced to finding the least necessary number of hauls for each locality in the

area when certain tolerance limits for the estimate of fish abundance are given. When each locality is trawled by the necessary number of hauls thus determined, fish abundance in the respective localities could be estimated with the same degree of accuracy.

Background

Since 1970 regular research trips have been made by the research vessel CHANGI in the South China Sea and its adjacent waters. Between 1970 and 1971, most of the research cruises to the South China Sea were concentrated in the area along the east coast of the Malay Peninsula extending from waters off the Gulf of Thailand to the vicinity of Singapore. For the purpose of the present exercise only the data collected by research cruises specially designed to cover as wide an area as possible are considered.

Evaluation of optimum number of hauls

A total of 286 hauls was made in this relatively wide area east of the Malay Peninsula. It contained 61 blocks, each of which is 30 nautical miles square. Basing on the values of mean catch, coefficient of variation, total number of hauls, and the number of trips visited in each block, the area was divided into three subareas. When subdividing the area, precaution was taken so that these blocks in each subarea were spatially continuous and the above values in each block were not greatly different from those within the subarea. As shown in Fig. 1, subarea-I contains 13 blocks and is located along the east coast of the Malay Peninsula; subarea-II comprises 17 blocks which extend eastwards in the shape of a rectangle; the remaining 31 blocks are contained in the subarea-III. Of the 286 hauls, 116 were made in subarea I, 76 in subarea II and 94 in subarea III. The number of hauls per unit block ranged from 3 to 18, 3 to 10, and 1 to 8 for the subareas I, II and III respectively.

The frequency distributions of catch per haul for the respective subareas were compared. Their distribution patterns were those of the Polya-Eggenberger¹⁾ model and these are shown in Fig. 2 together with the expected ones from the model. The statistics \bar{x} and \hat{k} necessary for the

further mathematical procedure were calculated for the respective subareas. The arithmetic means of catch \bar{x} 's for the subareas I, II and III were 3.84, 4.96 and 2.19 respectively. These \bar{x} 's are given in a converted unit, and could be reconverted into the original unit in kg. by multiplying with the value by 50. The values of \hat{k} were calculated by the method of maximum likelihood, and were 2.93, 10.39, and 8.51 for the subareas I, II and III respectively. The goodness-of-fit by the chi-square test showed that agreement of the respective observed distributions with the P.E. model was accepted at the 95% probability level. When the P.E. model is suitable for the sample, an index of the precision D of the estimate of fish abundance is given by the following expression (Elliott, 1971):

$$D^2 = \frac{t^2}{n} \left(\frac{1}{\bar{x}} + \frac{1}{\hat{k}} \right) \quad (1)$$

where t is found in Student's t-distribution. By the substitution of the values \bar{x} and \hat{k} into the above equation and with the aid of a table of t-distribution, D can be numerically expressed as a function of the number of hauls n at the desired confidence limits of t. The results, calculated at 95% confidence limits, for the respective subareas are shown as an example in Table 1.

As shown in the table, when the desired tolerance limits are given to be $D = 0.2$, sixty hauls are necessary for the subareas I and III, while thirty hauls are enough for the subarea-II. Considering the present research facilities and statistical accuracy, the above number of hauls may be optimum.

Conclusion

The area to the east of the Malay Peninsula is roughly divided into three subareas, and superiority of trawl fishing ground is in the order of the subareas II, I and III. When an error of 20% can be tolerated for the estimate of fish abundance, the least necessary number of hauls was calculated to the respective localities in the area. The number of hauls was different from locality to locality and a total of about 150 hauls is required to cover the whole area.

When a more detailed survey is necessary for these localities, we could take precautions about the optimum number of hauls for the respective localities. By repeating the survey based on such a plan, the spatial and seasonal characteristics on the trawl fishing condition could perhaps be clarified.

Reference

Elliott, J. M. 1971. Some methods for the statistical analysis of samples of benthic invertebrates, *Fresh-water Biol. Assoc.*, Scient. Pub. No. 25, 126-131.

Table 1. D at 95% confidence limits

n	3	5	10	20	30	50
$D_I^{(2)}$	1.93	0.96	0.55	0.36	0.28	0.21
D_{II}	1.35	0.67	0.39	0.25	0.20	0.15
D_{III}	1.88	0.94	0.54	0.35	0.28	0.21

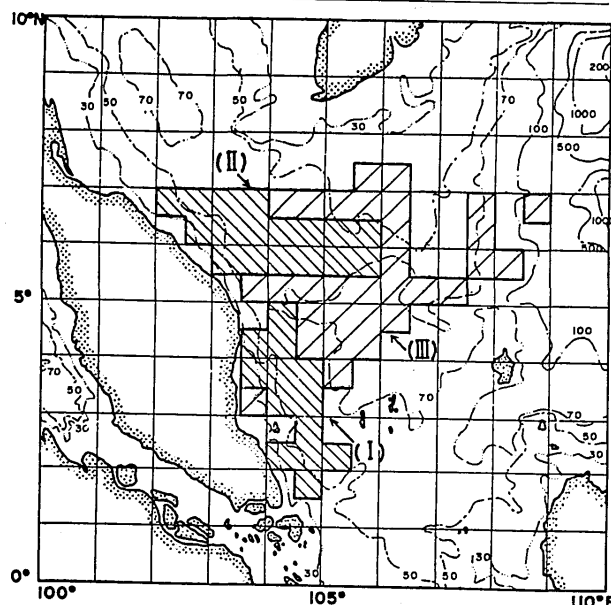

Fig. 1 Experimental trawled area along east coast of Malay Peninsula. Depth is shown in meter.

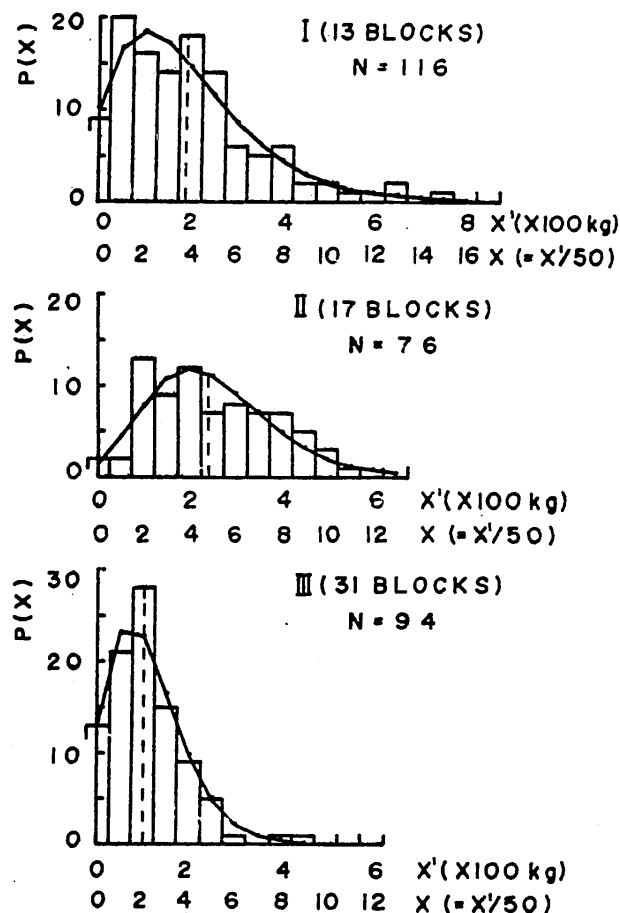

Fig. 2 Observed and expected frequencies plotted against catch per haul. Data from three subareas off east coast of Malay Peninsula.

Fish School Structure of Red Snappers
and Bigeye Snappers in the South China Sea

by

Otohiko Suzuki

Marine Fisheries Research Department
Southeast Asian Fisheries Development Center

Abstract

Towards the end of 1971, a systematic trawl survey was made in a narrow restricted area within the MFRD Reference Area. Throughout all the hauls red snappers and bigeye snappers were dominant in catch, as observed commonly in the South China Sea, and in most cases they were caught together in the South China Sea, and in most cases they were caught together in every haul. Moreover, it was often observed that when either of them showed an extremely high catch, the other was extremely low. The above seems to suggest that the center of a fish school may not coincide with that of another species, but the domain occupied by the former is partly overlapped with that of the latter inhabiting adjacently.

Using a simple mathematical model, some characteristic values on an average dispersion pattern of the species of fish schools on whose circumferences 50 kg/hour could be expected are almost the same and are 5 to 6 nautical miles. The maximum catch of red snappers and bigeye snappers which could be expected at the centers of the respective fish schools are 210 and 270 kg/hour respectively.

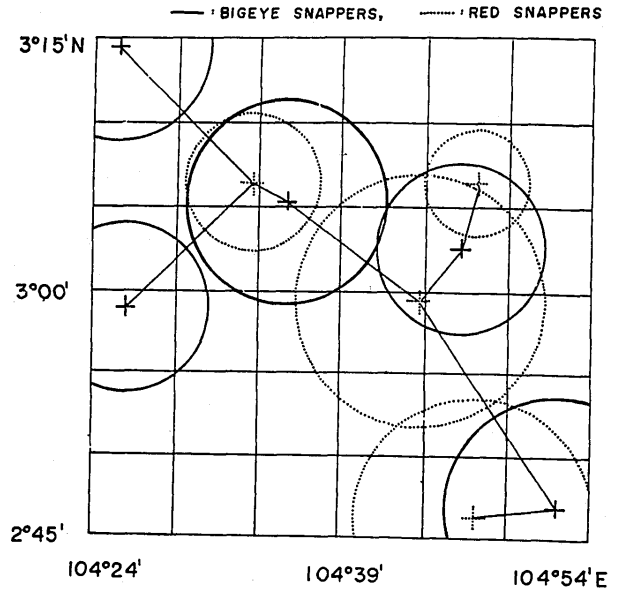

Fig. 2 Spatial arrangement of circular fish schools of red snappers and bigeye snappers.

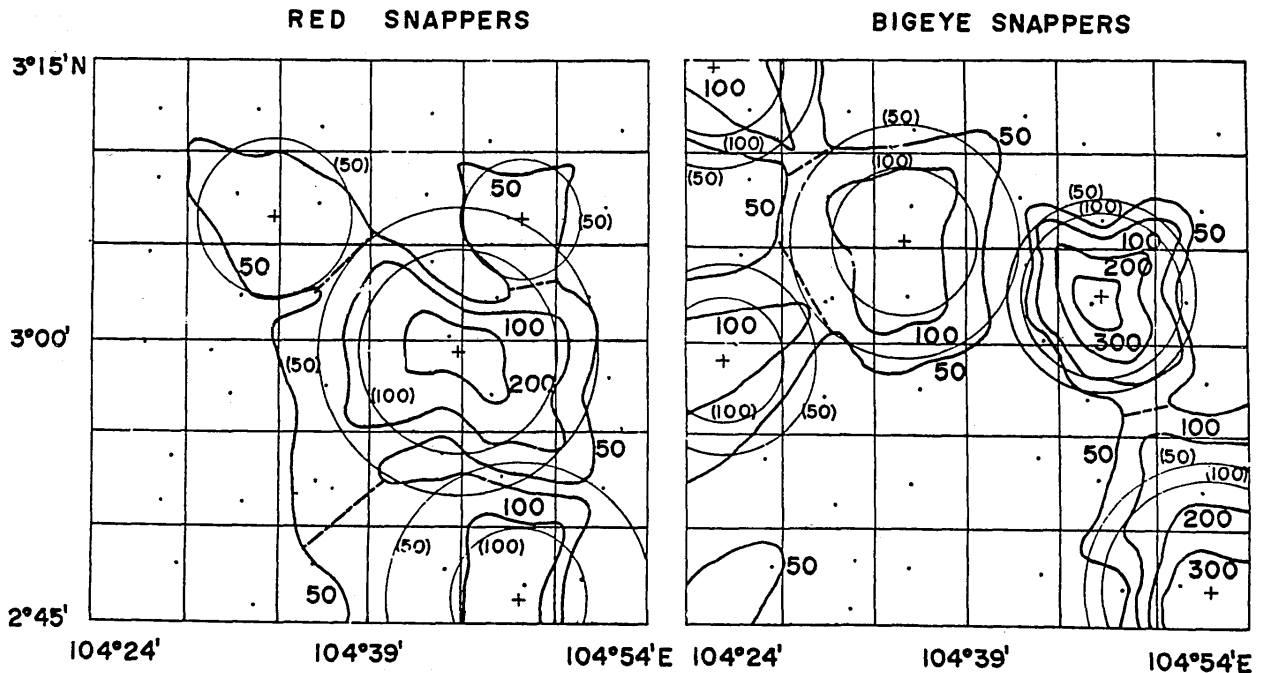

Fig. 1 Isopleths of catch and approximated circles for red snappers and bigeye snappers. Figures show densities of fish schools, parenthesized ones for circles.

Introduction

Red snappers, *Lutjanus* spp., and bigeye snappers, *Priacanthus*, spp., are the most dominant and economically important demersal fish species of trawl fishing in the southern part of the South China Sea. They constitute nearly 40% in weight of the total catch.

Both species are usually caught together in the same hauls. However, it has been frequently observed that when either of them shows extremely high catch, the other is extremely low. This suggests that some relationship on the spatial dispersion pattern exists between red snappers and bigeye snappers.

Intensive trawl fishing in small confined area

Towards the end of 1971, a series of experimental trawl fishing was conducted in a narrow restricted area, enclosed by 2°45'N and 3°15'N in latitude, and 104°24'E and 104°54'E in longitude. In this area isobaths run from northwest to southeast and the depth increases gradually towards the northeast. However, the bottom is almost flat and the depth ranges 60 to 55 m. in most parts within the area. During the period a current of about one knot flowed in a southerly direction, because of the prevailing northeast monsoon.

The whole area was covered with thirty-six hauls of about one hour each for the first six days, and the research was repeated in certain areas with a further ten hauls during the last two days. The location of each trawl operation was arranged in almost equi-distance. As has been commonly observed in the South China Sea, red snappers and bigeye snappers were dominant and were caught together in most hauls.

Observed dispersion pattern of red snappers and bigeye snappers

Using the data of the first thirty-six hauls, the isopleths of catch were drawn for the respective species of fish. The dispersion patterns of both species shown by the isopleths suggest the existence of some fish schools for the respective species (Fig. 1). Although the patterns are irregular in size and shape, each fish school could be approximated to some isolated or partly overlapped circles. In the figure the circles of 50 and 100 kg/hour are illustrated.

The circles approximated to 50 kg/hour-contour for both species of fish are shown in Fig. 2. It is clearly seen that the circular fish schools of the two different species are overlapping. Another interesting feature is that the fish schools of both species were along the same isobath running from the northwest to the southeast corner of the trawled area.

Theoretical model

We introduce here a simple model that each fish species disperses to form several two-dimensional Gaussian distributions. Next we suppose that the two different species of fish schools A and B are located at a constant distance d between the centers of both fish schools, and the respective domains occupied by them are partly overlap-

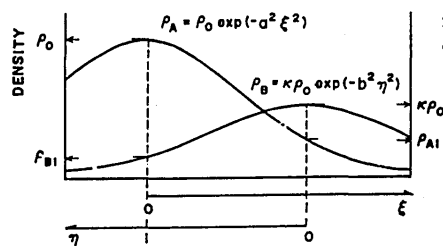

Fig. 3-a
Two adjacent fish schools overlapping each other.

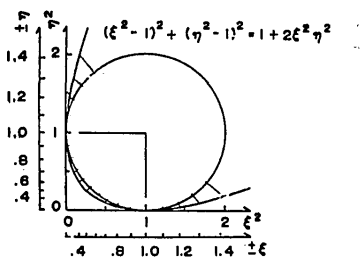

Fig. 3-b
Parabola
 $(\xi^2 - 1)^2 + (\eta^2 - 1)^2 = 1 + 2\xi^2 \eta^2$
= 1 + 2\xi^2 \eta^2 shown
together with circle
 $(\xi^2 - 1)^2 + (\eta^2 - 1)^2 = 1.$

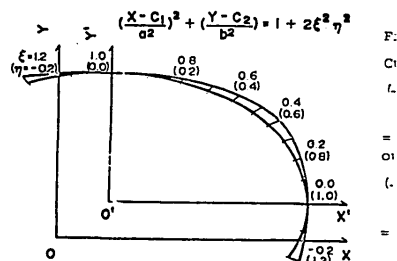

Fig. 3-c
Curve of
 $(\frac{X-C_1}{a})^2 + (\frac{Y-C_2}{b})^2 = 1 + 2\xi^2 \eta^2$ shown by
outer one and ellipse
 $(\frac{X-C_1}{a})^2 + (\frac{Y-C_2}{b})^2 = 1$ by inner one.

ping each other. For simplicity, our discussion will be confined to a one-dimensional problem (Fig. 3-a). Considering the coordinate system in Fig. 3-a, the following relation must be satisfied,

$$\xi + \eta = 1 \quad (1)$$

where $\xi = x/d$ and $\eta = y/d$. We distinguish between the densities of fish schools A and B by taking the subscripts A and B, and let the densities at the centers be ρ_0 and $\kappa\rho_0$ for the species A and B respectively. Then we have the following relations:

$$\rho_A = \rho_0 \exp(-a^2 \xi^2) \quad (2)$$

$$\rho_B = k\rho_0 \exp(-b^2 \eta^2) \quad (3)$$

where a and b are constants depending on the dispersion pattern. Denoting the densities of the fish schools A and B at $\xi = \eta = 1$ by ρ_{A1} and ρ_{B1} respectively, the following expressions can be obtained:

$$\frac{1}{a^2} (\ln \rho_A - \ln \rho_{A1}) = -(\xi^2 - 1) \quad (4)$$

$$\frac{1}{b^2} (\ln \rho_B - \ln \rho_{B1}) = -(\eta^2 - 1) \quad (5)$$

Taking the equation (1) into consideration, the above equations can be rewritten as follows:

$$\left(\frac{X - C_1}{a^2}\right)^2 + \left(\frac{Y - C_2}{b^2}\right)^2 = 1 + 2\xi^2\eta^2 \quad (6)$$

where $X = \ln \rho_A$, $C_1 = \ln \rho_{A1}$, $Y = \ln \rho_B$, and $C_2 = \ln \rho_{B1}$. Referring to Fig. 3-b and introducing a parameter $\theta = \tan^{-1} (1 - \eta^2)/(1 - \xi^2)$, the equation (6) can be solved graphically (Fig. 3-c). As shown in the figure, the curve of the equation (6) is in contact with an ellipse at the apices $(C_1, C_2 + b^2)$ and $(C_1 + a^2, C_2)$. The center of the ellipse is at the point (C_1, C_2) on the $X - Y$ plane and the major and minor axes are $2a^2$ and $2b^2$ respectively.

Assume that we collect samples continuously moving along the ξ -axis in Fig. 3-a. When either catch from the fish school A or B thus obtained is plotted against the other on a double-log section paper, the plots should align to form the curve given by the equation (6). From the curve we can determine all the constants contained in the equation (6). Moreover, equating the equations (2) and (3) and eliminating ρ_0 , we can obtain the relation between the relative sizes of the two fish schools:

$$a^2 \xi^2 - b^2 \eta^2 = \ln(1/k) \quad (7)$$

From the equations (6) and (7), we can estimate the densities and the relative sizes of the fish schools. When the distance between the centers of fish schools is determined by the other method, the size of fish schools can be given in absolute values.

Results and Discussion

The catch of red snappers in each haul was plotted against that of bigeye snapper of the same haul on a double-log graph paper. As shown in Fig. 4, the plots distribute widely on the graph paper in such a manner that they cover almost the whole area enclosed by the rectangular axes and the outermost plots arranged to form nearly a part of an ellipse-like curve. The plots arranged in the outermost region and formed a part of the curve can be regarded as the similar ones to those on the axis connecting the centers of fish schools in the theoretical model. Actually the locations from which these plots were obtained were arranged almost linearly along the diagonal connecting the northwest and southeast corners of the area trawled. The other plots scattered in the inner part could be interpreted as the data at locations off the axis. Emphasis should be placed on that in the model we have dealt with a simple case of two fish schools. Actually, however, there are many fish schools for the respective species, therefore the curve from the actual data can be

regarded as that of an average pattern for many fish schools.

As mentioned before, the curve of the equation (6) is in contact with an ellipse at its two apices. Therefore, once the coordinates of the apices are determined, the curve of the equation (6) can be given graphically. In the proximity of the two apices $(C_1, C_2 + b^2)$ and $(C_1 + a^2, C_2)$ the elliptic curve could be approximated by the parabolas $Y = a_0 + a_1 X + a_2 X^2$ and $X = b_0 + b_1 Y + b_2 Y^2$ respectively.

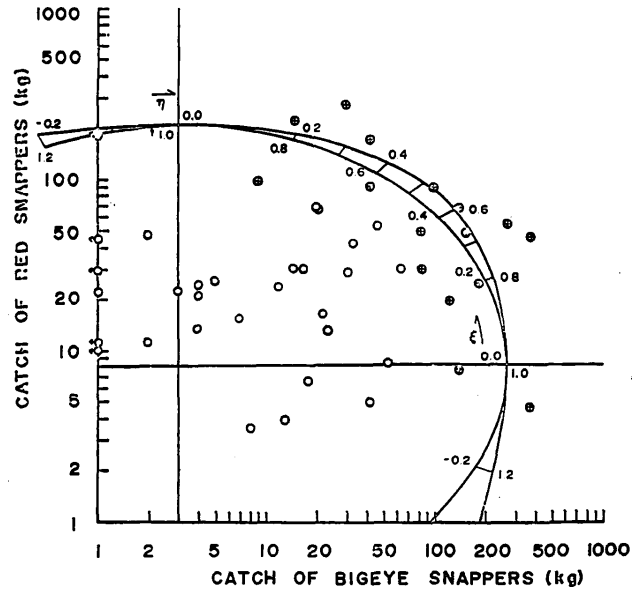

Fig. 4 Catch of red snappers plotted against that of bigeye snappers. Theoretical curve is approximated to outermost seventeen plots.

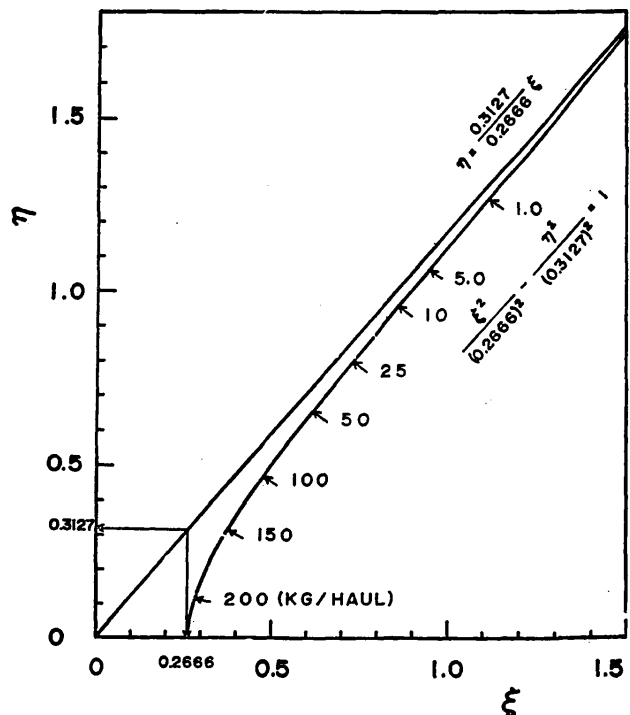

Fig. 5 Relation between relative sizes of fish schools of bigeye snappers and red snappers on an averaged pattern. Figures are for respective levels of densities of fish school.

Seventeen plots arranged in the outermost part on the double-log paper were selected arbitrarily and to these plots the above parabolas were fitted by the method of least squares. Thus the coordinates of two apices and therefore the constants C_1 , C_2 , a^2 and b^2 in the equation (6) were obtained. In Fig. 4 the curve of the equation (6) is shown together with the ellipse. The characteristic values thus obtained for the dispersion pattern of bigeye snappers and red snappers are as follows,

Bigeye snappers: $\rho_0 = 270$, $\rho_{A1} = 3$, $a^2 = 4.500$,

Red snappers: $\kappa\rho_0 = 210$, $\rho_{B1} = 8$, $b^2 = 3.268$,

where the densities are given in kg/hour. Substituting the constants $a^2 = 4.500$, $b^2 = 3.268$, and $1/\kappa = 1.377$ into the equation (7), we have the following numerical relation between ξ and η :

$$\frac{\xi^2}{(0.2666)^2} - \frac{\eta^2}{(0.3127)^2} = 1 \quad (7)$$

The above relation is shown in Fig. 5 and in the figure different levels of densities of fish schools are inserted. From the figure the radii of circular fish schools of bigeye snappers and red snappers on whose circumferences 100 kg/hour catch could be expected are 0.48 d and 0.47 d respectively, where d is the mean distance between the centers of fish schools for the two different species located adjacently, while the radii for 50 kg/hour are 0.62d and 0.65d respectively.

From Figs. 1 and 2, each distance between the centers of two adjacent circles occupied by the different species was measured and the mean d was calculated to be 8.0 nautical miles. The radii of the two different fish schools on whose circumferences 50 and 100 kg/hour catch could

SEAFDEC/SCS.73: S-8

Preliminary Observation on the Distribution and
Catch of the Shovel-Nosed Lobster, *Thenus orientalis* Lund in
South China Sea

by

Akihiko Shirota and Anuwat Ratanachote

Marine Fisheries Research Department
Southeast Asian Fisheries Development Center
Changi Point, Singapore

Abstract

The shovel-nosed lobster, *Thenus orientalis* Lund, is a widely distributed and a commercially important crustacean in the South China Sea. To study its habitat, distribution and catch the data obtained by trawl operations carried out by Thai research vessels in 1967–1968 and by R/V CHANGI in 1972 were analysed.

In the South China Sea it is most abundant in the coastal waters of the Malay Peninsula, South Vietnam and Sibuyan Bay of Sarawak at depth of less than 50 m. and relatively good catch has been obtained from waters with sandy rather than muddy bottom. The catch at night time

be expected were measured and their means were calculated. The theoretical and observed radii for the respective species are compared in Table 1.

Table 1. Comparison between estimated and observed radii of circular fish schools

Species	for 50 kg/hour		for 100 kg/hour	
	Estimated	Observed	Estimated	Observed
Bigeye snappers	5.0	5.7	3.8	4.1
Red snappers	5.2	5.5	3.8	4.4

Radii are given in nautical miles

The theoretical values are lower than the observed ones but the difference between them are at most 15%. Such a degree of discrepancy may be permissible when the accuracy of field data is taken into account.

Conclusion

Using a simple mathematical model, some characteristic values on an averaged dispersion pattern of red snappers and bigeye snappers were estimated, and comparison was made between the theoretical and the observed ones. The agreement between them is satisfactory within a range of practical accuracy. Summarising, the radii of fish schools for both species on whose circumferences 50 kg/hour could be expected are almost the same, and are 5 to 6 nautical miles. The mean distance between the centers of the two fish schools located adjacently is about 8 nautical miles. The maximum catch of red snappers and bigeye snappers which could be expected at the centers of the respective fish schools are 210 and 270 kg/hour respectively.

is higher than that in the daytime. This phenomenon may be related to the feeding behaviour of this species as observed in the case of prawn.

1. Introduction

The shovel-nosed lobster, *Thenus orientalis* Lund, a commercially important crustacean, is commonly found in the tropical and subtropical waters. Although it is abundant and has become valuable in the Southeast Asian countries, very little is known about the species. In view of its importance the Marine Fisheries Research Department, Southeast Asian Fisheries Development Center (SEAFDEC), carried out preliminary studies on its habitat and distribution in the South China Sea.

2. Materials and methods

From April to June and in October 1972 samples of shovel-nosed lobster were collected in waters off Borneo and the Malay Peninsula by the research vessel CHANGI. For the studies of its habitat bottom samples were obtained by a SK mud collector and strained through a set of various mesh-sized nets. Some data from Thai research vessels obtained in 1967–1968 (Anon., 1967 and 1968) were also used in this study.

3. Results and discussion

The body length of *T. orientalis* collected by CHANGI in the South China Sea ranged from 5.8 cm. to 25.2 cm. with a mean length of 14.7 cm. and a mean weight of 76.0 g (range = 3.7 – 310.9 g). The relationship of carapace length (X) and body weight (Y) for both sexes is similar and is represented by $\text{Log } Y = 2.99 \text{ Log } X - 0.25$. Body length of *T. orientalis* for the biological minimum is 10.85 cm. and sex ratio of male to female is approximately 2:1.

The distribution of *T. orientalis* in the South China Sea is shown in Table I and Fig. 1.

The mean catch of *T. orientalis* ranged from 0.14 kg/hr to 4.52 kg/hr. Catch of more than 3.0 kg/hr was only found in coastal waters along the east coast of Malay Peninsula, the southeastern part of Vietnam and the Sibiu Bay of Sarawak. However, the values of mean catch per

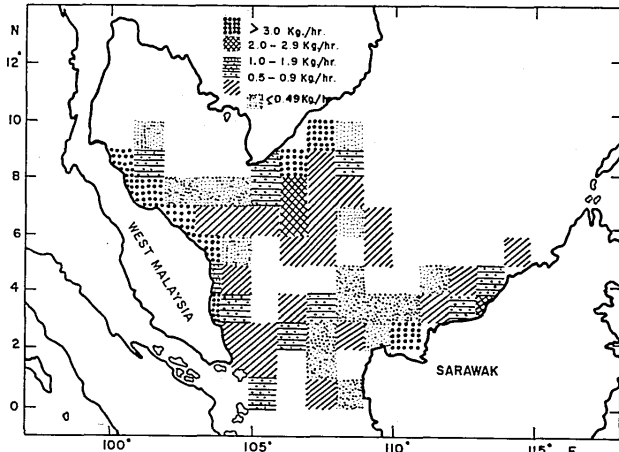

Fig. 1 Distribution of *Thenus orientalis* Lund in the South China Sea. (Trawl data collected by R/V CHANGI in 1972 and Thai research vessels in 1967–68)

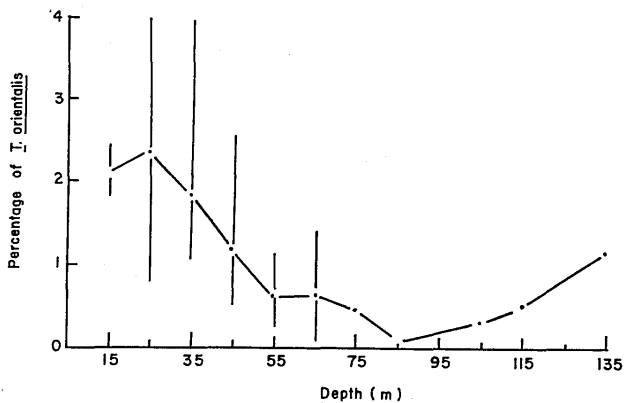

Fig. 2 Variation in catch of *Thenus orientalis* in relation to water depth.

hour are rather misleading since the gear used were not suitable for the survey.

The relationship between catch and depth is illustrated in Figure 2. It can be seen that *T. orientalis* is distributed in waters with depth of 12–140 m. and is most abundant in waters of depth less than 50 m.

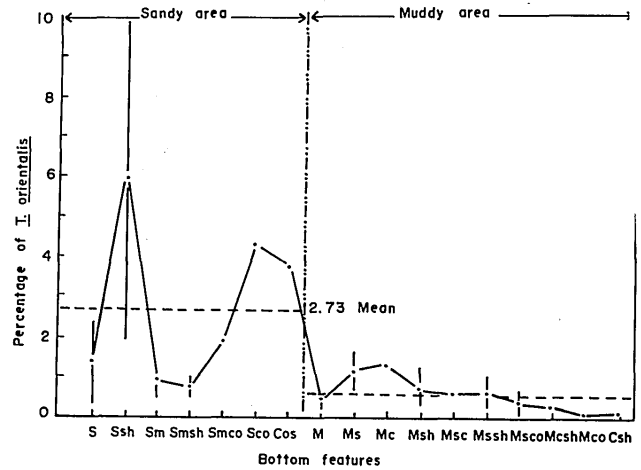

Fig. 3 Variation in catch of *Thenus orientalis* in relation to bottom features.

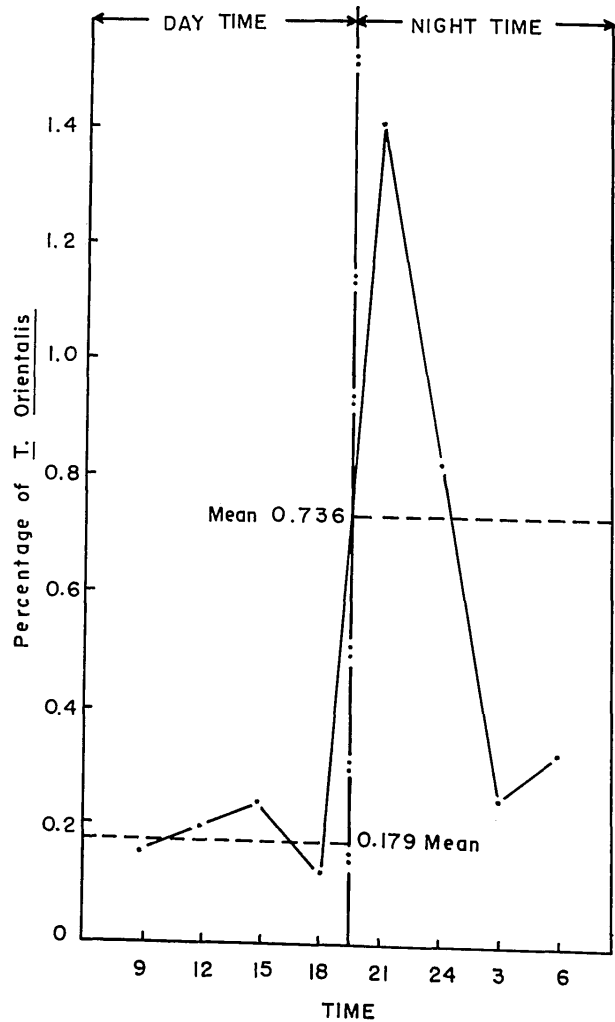

Fig. 4 Variation in catch of *T. orientalis* in day and night.

Table I. Catches and percentage of total catch of *T. orientalis* in the South China Sea

Station No.	Catches of <i>T. orientalis</i>									
	Mar.-Apr. 1967		May 1967		Nov.-Dec. 1967		Feb.-Mar. 1968		Apr.-Jun. 1972	
	kg/hr	%	kg/hr	%	kg/hr	%	kg/hr	%	kg/hr	%
005	-	-	-	-	-	-	1.33	1.16	-	-
007	-	-	-	-	-	-	0.50	1.09	-	-
008	-	-	-	-	-	-	0.33	0.93	-	-
104	1.04	0.72	-	-	-	-	-	-	0.08	0.25
105	-	-	0.83	1.43	-	-	-	-	-	-
107	-	-	-	-	-	-	0.25	1.67	-	-
203	0.85	0.32	-	-	-	-	-	-	-	-
204	1.78	1.52	0.37	1.70	-	-	-	-	0.16	0.16
205	-	-	0.75	1.24	-	-	-	-	-	-
206	-	-	-	-	-	-	1.00	1.60	-	-
207	-	-	-	-	-	-	0.25	0.46	-	-
208	-	-	-	-	-	-	0.50	0.32	-	-
209	-	-	-	-	-	-	0.40	0.56	-	-
210	-	-	-	-	-	-	0.50	0.16	5.50	7.75
303	3.83	0.94	-	-	-	-	-	-	-	-
304	2.53	0.76	-	-	-	-	-	-	0.24	0.17
306	-	-	-	-	-	-	0.50	0.48	-	-
307	-	-	-	-	-	-	1.00	0.82	-	-
308	-	-	-	-	-	-	0.40	0.31	-	-
309	-	-	-	-	-	-	0.14	0.03	-	-
310	-	-	-	-	-	-	0.33	0.41	-	-
311	-	-	-	-	-	-	0.57	0.94	-	-
312	-	-	-	-	-	-	1.25	2.80	1.23	2.01
313	-	-	-	-	-	-	2.00	1.20	-	-
403	1.91	1.27	0.23	0.63	-	-	-	-	-	-
404	-	-	0.40	0.32	-	-	-	-	1.08	1.38
408	-	-	-	-	-	-	0.25	0.21	-	-
411	-	-	-	-	-	-	0.25	0.36	-	-
412	-	-	-	-	-	-	0.75	0.36	-	-
413	-	-	-	-	-	-	1.83	0.83	0.28	0.30
502	5.42	4.49	-	-	-	-	-	-	-	-
503	5.42	4.75	0.50	0.95	-	-	-	-	-	-
504	-	-	0.31	0.31	-	-	-	-	-	-
506	-	-	-	-	-	-	0.50	1.09	-	-
507	-	-	-	-	-	-	0.75	0.45	-	-
509	-	-	-	-	-	-	0.75	1.45	-	-
514	-	-	-	-	-	-	0.60	0.31	0.51	0.21
601	-	-	-	-	3.75	2.14	-	-	-	-
602	5.86	3.75	3.10	1.71	1.25	0.46	-	-	-	-
603	-	-	0.50	0.47	0.50	0.16	-	-	-	-
604	-	-	0.60	0.70	-	-	-	-	1.21	1.00
605	-	-	0.67	0.44	-	-	-	-	-	-
606	-	-	-	-	-	-	2.00	0.87	-	-
607	-	-	-	-	-	-	0.75	3.36	-	-
608	-	-	-	-	-	-	0.33	0.789	-	-
609	-	-	-	-	-	-	0.50	1.73	-	-
700	-	-	-	-	3.28	1.19	-	-	-	-
701	-	-	-	-	3.87	0.99	-	-	-	-
702	-	-	-	-	0.50	0.25	-	-	-	-
703	-	-	-	-	0.28	0.09	-	-	-	-
704	-	-	-	-	0.37	0.23	-	-	-	-
705	-	-	-	-	1.87	1.18	-	-	-	-
706	-	-	-	-	3.17	1.54	1.50	3.93	-	-
707	-	-	-	-	-	-	0.75	3.72	-	-
708	-	-	-	-	-	-	0.50	0.38	-	-
800	-	-	-	-	3.00	1.80	-	-	-	-
801	-	-	-	-	1.00	0.34	-	-	-	-
805	-	-	-	-	1.00	0.69	-	-	-	-
806	-	-	-	-	3.50	1.86	2.50	1.69	-	-
807	-	-	-	-	-	-	0.50	1.92	-	-
808	-	-	-	-	-	-	1.00	0.39	-	-
900	-	-	-	-	0.33	0.06	-	-	-	-
907	-	-	-	-	-	-	3.25	15.25	-	-
908	-	-	-	-	-	-	0.33	0.48	-	-

Fig. 3 shows the variation of catch in relation to the physical features of sea bottom. From the catch records it appears that the most suitable habitat for this species is sandy bottom with shell pieces.

The variation of catch in relation to the time of operation is shown in Fig. 4. The figure shows that the catches in the night are higher than those in the day time. This is probably associated with its feeding behaviour and may suggest that it buries itself under the substratum in the day, as is the case of some prawn species.

From the encouraging results of the preliminary survey on the distribution and catch of the shovel-nosed lobster further studies need to be carried out before the resource of this economically important crustacean can be fully developed and exploited.

SEAFDEC/SCS. 73: S-10

Results of the Experimental Trawl Fishing
in the South China Sea by
R/V CHANGI in the Years 1970 to 1972

by
Tetsushi Senta, Sen-Min Tan and Pang-Yong Lim
Marine Fisheries Research Department
Southeast Asian Fisheries Development Center
Chagi Point, Singapore

Abstract

From the data collected by R/V CHANGI from 1970 to 1972 the trawl fishing grounds in the South China Sea were discussed. To examine the trend of demersal fish resources, the data collected by R/V HAI-CHING in

1960-1962 were also utilized.

The areas near to Tioman Island and off the coast of Sarawak were considered as promising fishing grounds, although the mean catch per hour was not too good. Red snappers predominated the catch in most areas, while

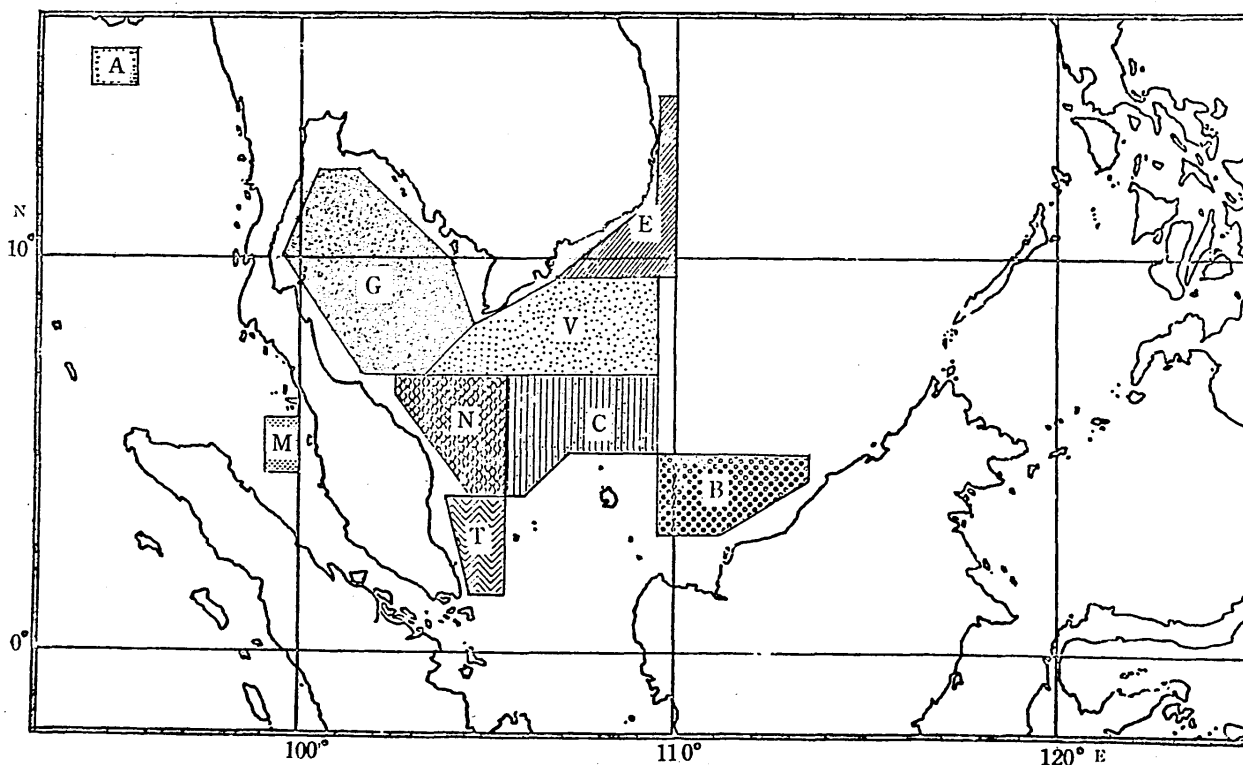

Fig. 1 Map to show the areas of survey.

4. Acknowledgement

The authors are indebted to M. Chen Foo Yan, Chief of the Marine Fisheries Research Department, SEAFDEC, for his critical reading of the manuscript.

Reference

- Anonymous. 1967. The results of the fisheries resources investigation in the Indian Ocean and South China Sea, 1967. Exploratory Fishing Unit, Dept. Fish., Min. Agr., Contribution 4:1-387 (in Thai).
- Anonymous. 1968. The results of the fisheries resources and oceanographic survey in the Sunda continental shelf and the South China Sea, 1968. Exploratory Fishing Unit, Dept., Fish., Min., Agr. 1-466 (in Thai).

species composition in the waters off Vietnam was quite different.

Although seasonal fluctuations of both mean catch per hour and species composition were not very much, a remarkable annual fluctuation was observed in species composition.

Good catches were usually obtained from depths of 51–100 m.

Changes in demersal fish resources in the last ten years, both in quantity and quality, if any, may be in a desirable direction.

More study on economic and biological aspects are needed to attain a full exploitation of the fishery resources of the region.

1. Introduction

The research vessel CHANGI of the Marine Fisheries Research Department, Southeast Asian Fisheries Develop-

ment Center, has been carrying out investigations on demersal fish resources in the Southeast Asian region since early 1970. During the past 3 years, from 1970 to 1972, CHANGI conducted 24 cruises for experimental trawl fishing and made 680 hauls. The present paper summarizes the trawl results of 21 cruises and 623 hauls carried out mainly in the South China Sea.

2. Fishing Gear and fishing grounds

1.2 Vessel and trawl net

R/V CHANGI is a steel boat, 386.6 tons in gross tonnage, equipped with a main engine of 1000 H.P., designed mainly for both stern trawl and tuna long line. The trawl net is four-seamed type, with head rope length of 36 m. and cod-end mesh size of 56 mm. The net was towed at a speed of 2.5 to 4.5 knots for an average of 1.5 hours per haul. The towing speed varied according to the velocity and direction of the current and the bottom

Table I. Number of Trawl hauls and total catch by area and by month by R/V "Changi" in 1970 – 1972

1. 1970											
Date	Area ^{1/}	T	N	B	V	C	G	M	A	Total	Total catch (tons)
8–30, January		13					21			34	4.1
18–20, February		7	6							13	1.4
20–26, April		2		23						25	4.0
14–22, May		1		26		7				34	5.1
15–21, June		24	10							34	5.1
4–26, July			38			6	3			47	8.8
13–19, August			8			23				31	4.3
15–22, October		11	17							28	7.1
17–23, November		17	12							29	6.9
Total		75	91	49		36	24			275	
Total catch (tons)		14.2	18.2	8.3		3.6	2.5				46.8
2. 1971											
14–26, April		12	14			21				47	6.6
1–12, June		12	14			13				39	9.4
16–27, July								7		7	1.7
1–13, September		10			39					49	7.2
12–24, October		6		37						43	10.4
28 Nov. – 5 December		46								46	11.2
13–20, December								17		17	3.1
Total		86	28	37	39	34		24		248	
Total catch (tons)		19.9	6.1	9.2	4.4	5.2		4.8			49.6
3. 1972											
19–23, January		18								18	5.6
4–10, February								23		23	3.3
20–24, April		5	5							10	1.3
17, June		4								4	0.5
6–13, October		35								35	8.5
24–30, October		28								28	5.7
15–24, November				29						29	5.4
28 Nov. – 13 December									10	10	6.4
Total		90	5	29				23	10	157	
Total catch (tons)		20.9	0.7	5.4				3.3	6.4		36.7

^{1/} T: adjacent to Tioman Island, N: northern area off east coast of Malay Peninsula, B: north coast of Borneo, V: south coast of Vietnam, C: central area of south-western region of the South China Sea, G: Gulf of Thailand, M: off Penang Island (Straits of Malacca), A: northern part of Andaman Sea.

topography. During the initial period of operation most towing time ranged from 60 to 120 minutes. However, in 1972 towing time was limited to 1.5 hours whenever possible.

2.2 Areas surveyed and frequency of operation

Figure 1 illustrates the 8 areas (T, N, B, V, C, G, M and

A) surveyed by CHANGI in 1970–1972. The data from area M are utilized in this report only for the purpose of comparison but those from area A are fully discussed in a separate paper (Senta and Tan, 1973). Table I illustrates the number of hauls and total catch by area and by month.

Table II. Mean catch per hour (C/h) and coefficient of variation (C.V.) by area and by year

Year	Area	T	N	B	V	C	G	M
	Item							
1970	C/h kg	159.9	154.5	149.4	—	80.1	93.2	—
	C.V. %	92.3	65.9	86.9	—	81.4	89.7	—
1971	C/h kg	175.9	126.0	175.7	74.2	91.1	—	130.6
	C.V. %	59.7	53.9	65.7	97.1	62.6	—	63.3
1972	C/h kg	176.8	120.0	154.5	—	—	—	170.5
	C.V. %	82.3	42.2	70.0	—	—	—	76.7

3. CATCH AND SPECIES COMPOSITION

3.1 Catch per hour and its fluctuation by area

The mean catch per hour for each area during the 3 years is shown in Table II. While areas T and B gave the best mean catch values of more than 150 kg/hour, areas V, C and G gave a value of less than 100 kg/hour. The remaining two areas, N and M, may be considered to give intermediate values of mean catch per hour, although the values varied from year to year.

The value of coefficient of variation (C.V.), which

shows the degree of fluctuation of catch either spatially or temporally, was always lowest in area N. The values of C.V. were nearly the same in areas T, B, C, G and M, although the values in any of these areas fluctuated considerably from year to year. The value was considerably higher in area V, thus suggesting that the catch per hour fluctuated markedly in this area.

Based on trawl catches these areas can be categorized into 3 types of fishing grounds. Areas T and B are considered as good fishing grounds with high catches; areas N and M are intermediate while areas V, C and G are regarded as poor fishing grounds.

Table III. Percentage in weight of major species in total trawl catch by area of 1970

Species*	Area	T	N	B	C	G
1 Red snapper		25.2	13.6	25.3	15.5	26.6
2 Bigeye snapper		8.1	17.1	18.9	10.9	1.6
3 Threadfin snapper		3.9	6.4	2.8	3.9	2.9
4 Triggerfish		5.7	9.7	4.5	3.2	1.9
5 Jacks and scad		4.7	5.7	3.3	15.0	4.4
6 Naked-headed sea bream		2.6	3.2	3.9	2.7	0.2
7 Thick-lip grunt		5.4	2.8	7.3	0.0	2.4
8 White snapper		3.7	4.6	2.4	1.0	4.8
9 Lizardfish		2.7	5.8	2.3	10.5	3.1
10 Goatfish		4.0	8.7	4.2	6.5	4.5
11 Catfish		1.3	2.9	3.0	1.3	0.7
12 Grouper		1.9	1.7	3.0	0.9	0.7
13 Rabbitfish		0.5	0.9	0.0	3.1	0.2
14 Soldierfish		0.0	0.5	0.1	0.4	0.0
15 Barracuda		0.1	0.6	0.5	0.1	1.4
16 Sea bream		0.0	0.0	0.0	0.0	0.0
17 Butterfish		0.0	0.5	1.4	0.0	0.0
18 Croaker		0.0	0.1	0.1	0.2	0.0
19 Shark		3.1	2.8	2.0	7.2	0.5
20 Others		14.3	10.1	7.5	12.8	11.6

*1: large sized lutjanid,

2: Priacanthus,

3: nemipterid,

4: Abalistes,

5: carangoid,

6: Gymnocranius,

7: Plectorhynchus,

8: Pristipomoides,

9: Saurida and Trachinocephalus,

10: mullid,

11: Tachysurus,

12: epinephelid,

13: Siganus,

14: Holocentrus,

15: Sphyaena,

16: Taius and Argyrops,

17: Ariomma,

18: Sciaenid,

19: small sized sharks

Table IV. Percentage in weight of major species in total trawl catch by area in 1971

Species \ Area	T	N	B	V	C	M
1 Red snapper	22.2	24.9	22.4	19.2	10.3	7.7
2 Bigeye snapper	18.3	10.6	15.2	1.1	18.2	11.8
3 Threadfin snapper	11.2	2.4	8.7	3.9	10.5	9.6
4 Triggerfish	7.2	8.1	4.6	0.9	9.9	5.3
5 Jacks and scad	5.9	8.4	3.1	11.7	6.3	8.4
6 Naked-headed sea bream	5.6	3.9	4.8	3.5	5.1	2.1
7 Thick-lip grunt	4.1	3.2	6.3	6.1	0.6	1.6
8 White snapper	3.7	3.7	2.9	4.1	2.5	3.7
9 Lizardfish	3.6	3.1	3.9	14.6	5.9	2.3
10 Goatfish	3.0	6.3	9.1	4.4	6.9	12.3
11 Catfish	1.8	1.6	1.6	0.0	3.7	8.3
12 Grouper	1.7	1.8	2.0	2.6	2.2	2.1
13 Rabbitfish	0.5	0.3	0.1	0.2	0.4	10.1
14 Soldierfish	0.1	0.3	2.9	0.1	0.1	0.7
15 Barracuda	0.1	6.2	0.2	0.0	0.0	0.0
16 Sea bream	0.0	0.0	0.3	1.7	0.0	0.1
17 Butterfish	0.0	0.0	3.7	17.3	0.3	0.1
18 Croaker	0.0	0.1	2.4	0.0	0.5	0.0
19 Shark	2.9	3.5	1.8	2.2	8.5	1.3
20 Others	8.1	11.6	4.0	6.4	8.1	12.5

3.2 Species composition in catch by area

Tables III, IV and V illustrate the percentages in weight of total catch for each of the major species in the respective areas and years. It can be seen that red snappers were always the most abundant fish in T, B, V and G, usually consisting of more than 20% of the total catch. In areas N and C, red snappers were still dominant, but with rather lower percentages (10–15%) except for area N in 1971 (25%). Among the red snappers *Lutjanus sanguineus* was the most important species, usually occupying about 70% of the total catch of snappers. Other important red snappers were *L. sebae* and *L. altifrontalis* (= *L. malabaricus phuketi*). Bigeye snappers, comprising mainly *Priacanthus tayenus* and *P. macracanthus*, were the next most abundant fish except in areas V, G and B where the fish occupied less than 2% of the total catch.

Percentages in weight of trawl catch for all other species varied considerably from area to area. Extreme examples of such a case are: In 1970 triggerfish occupied 9.7% in area N, but only 1.9% in area G; jacks and scad constituted 15.0% in area C, followed by 5.7% in area N; the percentages of lizardfish ranged from 10.5% in area C to 2.3% in area B. In 1971 lizardfish occupied 14.6% in area V, followed by 5.9% in area C; rabbitfish was caught in a significant amount only in area M; butterfish occupied 17.3% in area V, followed by 3.7% in area B and with negligible catches in other areas; barracuda were captured in much higher percentage in area N than in any other area. In 1972 the percentages of triggerfish ranged from 18.2% in area M to 0.6% in area B; catfish occupied 15.3% in area M, followed by 8.2% in area B; croaker, shad, golden snapper, grunter and conger eel occurred in significant amount only in area B.

Table V. Percentage in weight of major species in total trawl catch by area in 1972.

Species* \ Area	T	N	B	M
1 Red snapper	23.0	10.4	12.9	6.0
2 Big-eye snapper	16.0	38.2	0.8	13.4
3 Threadfin snapper	7.4	8.5	1.4	3.7
4 Triggerfish	8.4	9.0	0.6	18.2
5 Jacks & Scad	7.5	6.7	12.0	4.9
6 Naked-head sab.	4.5	3.1	0.2	4.2
7 Thick-lip grunt	4.1	1.6	2.6	5.4
8 White snapper	4.6	3.3	0.1	0.7
9 Lizardfish	4.0	2.7	3.1	0.0
10 Goatfish	4.7	6.0	0.0	5.7
11 Catfish	5.7	3.1	8.2	15.3
12 Grouper	5.5	0.8	1.3	3.0
13 Rabbitfish	0.0	0.2	0.0	3.3
14 Soldierfish	0.0	0.0	0.0	0.0
15 Barracuda	0.7	0.0	0.0	0.0
16 Seabream	0.0	0.0	0.0	0.0
17 Butterfish	0.0	0.0	0.0	0.0
18 Croaker	0.0	0.0	12.0	0.0
19 Spanish mackerel	0.2	0.0	1.1	1.1
20 Shad	0.0	0.0	10.9	0.0
21 Golden snapper	0.0	0.0	7.5	0.0
22 Grunter	0.0	0.0	3.5	0.0
23 Conger eel	0.0	0.0	1.5	0.0
24 Sharks	0.0	4.9	6.0	1.3
25 Others	3.0	0.6	12.8	13.5

* 19: *Scomberomorus*, 20: *Ilisha & Pellona*,
 21: *Lutjanus johnii*, 22: *Pomadasys*,
 23: *Muraenesox talabon*

Sea bream caught in area V was almost exclusively *Tautus tumifrons*, and those in other areas were *Argyrops spinifer*. Among those species which are included in "others" in Tables III-V, hairtail (*Trichiurus*), cobia (*Rachycentron*) pigfacefish (*Lethrinus lentjan* and *L. miniatus*), cuttlefish and squid, shovel-nosed lobster, etc. were of some importance sporadically.

In order to compare further the species composition in catch between areas, the community similarity index, $C\lambda$ (Morisita, 1959) was calculated for the data of 1970 and 1971. Before calculating the index, the catch record in weight of each species in each area was converted into an individual number by dividing the catch by an average body weight of the species. The latter was taken from the record of measurement on the catch made mainly in 1971. "Others" were omitted from the calculation.

The values of $C\lambda$ for every possible comparison of two areas in the respective years are shown in Table VI. The index becomes one when the communities of the two areas are the same and becomes zero when no common species is found between them. Furthermore, the index is almost independent of sample size provided that samples of either or both areas are not small.

In 1970, high values of $C\lambda$ were observed for every combination of two areas, most of them exceeding 0.9. The values are especially high between areas T and N, areas T and G, and areas C and G. Even between areas B and C where the lowest similarity was seen, the value of $C\lambda$ was still rather high.

At the left-bottom half of Table VI a remarkable difference of community between area V and the other areas is obvious, 4 out of 5 values of $C\lambda$ being 0.23–0.28. The higher value of $C\lambda$ between areas V and B (0.51) indicates the existence of more similarity of the community between them than those of the other areas.

The highest similarity of community in 1971 is seen between areas T and C, and followed by that between areas B and C, both with values of $C\lambda$ exceeding 0.9. Notwithstanding the proximity of area N to area T, the value of $C\lambda$ between these two areas was rather low as compared to those of the other values, except those of area V. On the other hand, the community of area M showed a rather high similarity with the other areas ($C\lambda$ being 0.76–0.86) excepting area V, in spite of the fact that area M is connected with the other areas only through the narrow Straits of Malacca.

Table VI. Community similarity index ($C\lambda$) between areas calculated for 19 major species in trawl catch in 1970 (right-top) and in 1971 (left-bottom)

	T	N	B	V	C	G	M
T		0.990	0.943	—	0.958	0.983	—
N	0.715		0.956	—	0.915	0.960	—
B	0.828	0.777		—	0.846	0.878	—
V	0.229	0.268	0.511		—	—	—
C	0.963	0.829	0.910	0.280		0.985	—
G	—	—	—	—	—		—
M	0.759	0.794	0.833	0.265	0.856	—	—

3.3 Seasonal fluctuation in catch and species composition

As shown earlier in Table I area T has been visited most frequently by CHANGI. Catch data in area T, therefore, was utilized for the purpose of analysing seasonal fluctuation in catch and species composition. Because of the scarcity or lack of data for some months, a year was arbitrarily divided into 4 periods: January–March, April–June, July–September and October–December.

The VII shows the number of hauls, catch and species composition for the respective periods in area T. Of the 251 hauls made in area T 143 hauls (57% of total) were operated in October–December, while only 10 hauls were made in July–September.

The catch was the best in the July–September period, with the highest value of mean catch per hour and the least value of C.V. This small fluctuation however, may be a superficial one, because all the hauls were made in the same cruise in September, 1971, thus being free from the influence of monthly or annual fluctuations. The values of mean catch per hour were almost the same in both periods of January–March and October–December, but the catches were more stable in the latter period. The April–June period gave a rather poor catch with a comparatively high fluctuation. However, even in the poorest quarter of January–April the mean of catch per hour in area T was actually not as bad as those of other areas in the South China Sea shown in Table II.

In all four quarters, red snappers occupied the highest weight percentage occupying 21–28% of total catch. Although the percentage of red snappers was lower in October–December than in the other periods the seasonal fluctuation in the relative abundance of the fish was not very much. Bigeye snapper comes next to red snapper except in January–March when catfish outweighed bigeye snapper. Threadfin snapper occupied the third position in July–September and October–December but with much lower ranking in the other periods, while triggerfish always maintained at the fourth or fifth position in weight percentage of catch.

In order to express the degree of seasonal fluctuation in relative abundance of a fish, the seasonal fluctuation index, SFI, as defined below was calculated.

Thus, the fishes in Table VIII can be divided into 4 groups according to the degree of seasonal fluctuation in their relative abundance. The following shows the grouping of the fishes.

- (a) Low seasonal fluctuation ($SFI < 2$): red snappers, triggerfish, naked-headed sea bream, white snapper, lizardfish and soldierfish.
- (b) Moderate seasonal fluctuation ($SFI = 2.1$ to 5.0): bigeye snapper, jacks and scad, thick-lip grunt, goatfish, grouper, rabbitfish, Spanish mackerel and shark.
- (c) High seasonal fluctuation ($SFI = 5.1$ to 10.0): threadfin snapper.
- (d) Extreme seasonal fluctuation ($SFI < 10.1$): catfish and barracuda.

The pattern of seasonal fluctuation in relative abun-

Table VII. Mean catch per hour, coefficient of variation and percentage in weight of major species in total catch by season in area T for 1970 – 1972

	Jan.–Mar.	Apr.–Jun.	July–Sept.	Oct.–Dec.	SFI*
Total number of hauls	38	60	10	143	
Total catch (kg)	8902	10947	2755	32056	
Mean catch per hour (kg)	175.6	148.8	184.4	176.4	
Coefficient of variation (%)	103.5	99.6	41.0	64.1	
Major species	%	%	%	%	
Red snapper	27.8	26.1	28.1	21.1	1.3
Bigeye snapper	9.0	8.3	14.2	18.5	2.2
Threadfin snapper	2.0	5.3	9.9	10.5	5.1
Triggerfish	7.1	6.1	6.1	5.5	1.3
Jacks and scad	2.4	5.0	8.4	7.8	3.4
Naked-headed sea bream	4.0	3.0	5.1	5.0	1.6
Thick-lip grunt	6.4	8.7	5.7	3.9	2.2
White snapper	3.6	4.7	3.3	4.6	1.4
Lizardfish	3.2	2.9	6.0	4.0	2.0
Goatfish	5.8	7.3	3.0	4.0	2.4
Catfish	11.5	2.5	0.7	1.3	14.5
Grouper	3.8	1.7	2.2	1.7	2.2
Rabbitfish	0.1	0.2	0.7	0.4	4.0
Soldierfish	0.0	0.1	0.0	0.1	2.0
Barracuda	1.7	0.2	0.3	0.0	18.0
Seabream	0.0	0.0	0.0	0.0	–
Spanish mackerel	0.1	0.1	0.5	0.9	4.5
Croaker	0.0	0.0	0.0	0.0	–
Sharks	3.5	3.0	1.4	3.8	2.6
Others	8.0	14.8	7.6	6.9	–

*SFI: Seasonal fluctuation index

dance of those fishes belonging to groups (b) and (c) is different according to the species. The percentages of bigeye snapper, threadfin snapper and Spanish mackerel were highest in October–December, followed by those in July–September. On the contrary, catfish and barracuda showed much higher percentage in January–March than in any other periods.

Table VIII shows the community similarity index between periods in area T. This table indicates a high similarity between January–March and April–June and also between July–September and October–December.

3.4 Annual fluctuation in catch and species composition

With reference to Table II the values of mean catch per hour in each area did not show a very high annual fluctuation, the difference between the highest value of mean catch per hour and the lowest value being less than 30% in any area. Among all the areas area T showed the least annual fluctuation, where the lowest value of 159.9 kg/hr in 1970 is only 10% less than the highest catch of 176.8 kg/hr in 1972.

The annual fluctuations of the species composition of trawl catch in areas T and B are discussed, based on the data obtained in the years 1970, 1971 and 1972. The other areas were excluded from this discussion because of insufficiency of data (Tables I, III, IV and V).

In all the three years surveyed red snapper predominated the catch in area T, occupying about 22–25% of the total catch. In 1971, 1972, bigeye snapper and threadfin snapper constituted a greater proportion of the catch than in 1970. The percentage of triggerfish was also

higher in 1971 and 1972 but only slightly in 1970. The catch of other fishes like white snapper, lizardfish, grouper, thick-lip grunt and goatfish did not show any large fluctuations. Although red snapper and bigeye snapper always occupied the top and second positions in abundance in the trawl catch, the ranking of the other fishes changed annually.

Table VIII. Community similarity index ($C\lambda$) between periods calculated for 19 major species in trawl catch in area T. The data for 1970 – 1972 are combined.

	Jan.–Mar.	Apr.–June	July–Sept.	Oct.–Dec.
Jan.–Mar.	–	0.934	0.743	0.770
Apr.–June	0.934	–	0.856	0.868
July–Sept.	0.743	0.856	–	0.988
Oct.–Dec.	0.770	0.868	0.988	–

Table IX. Community similarity index ($C\lambda$) between years calculated for 24 major species in area T (right-top) and B (left bottom)

	1970	1971	1972
1971		0.430	0.520
1971	0.475		0.958
1972	0.437	0.170	

The trawl catches in area B in 1970 and 1971 were not much different from the catch in area T, with red snapper predominating in the catch. Bigeye snapper and threadfin snapper were also quite abundant. However in 1972, the species composition differed considerably from that of the previous two years. Here red snapper, jacks and scad, croaker and shad were equally abundant. Bigeye snapper occupied only a small percentage of the catch. Threadfin and goatfish were also caught in negligible amounts. A considerable amount of golden snapper, conger eel, shad and grunter were caught in 1972, even though they were almost negligible or totally absent in 1970 and 1971.

The community similarity index, $C\lambda$, was calculated and shown in Table IX for further examination of differences in species composition between years. The table indicates that between 1971 and 1972 the species composition in area T was quite similar but between 1970 and 1971 and between 1970 and 1972, the $C\lambda$ were rather low, much lower than those between periods (Table VIII).

In area B, $C\lambda$ showed an extremely low value between 1971 and 1972. The similarity was slightly greater between 1970 and 1971 and between 1970 and 1972.

The relatively low values of $C\lambda$ in general, which suggests the existence of annual fluctuation in species composition, may be attributed to the annual fluctuations of rankings of main species other than red snapper bigeye snapper. The extensively low $C\lambda$ in area B between 1971 and 1972 may be related to the locality of the fishing ground. In 1972, most of the trawl operations were carried out in shallow waters (26–48 m), close to the coast. Hence the water conditions here differed considerably from the areas trawled in 1970 and 1971 which were towards the open sea.

Table X. Number of hauls by depths of fishing ground in each area, 1971

Depth(m)	26-50	51-75	76-100	101-125	126-150	Total
Area T	8	78				86
N	5	23				28
B	6	15	11	5		37
V	10	9	8	8	4	39
C		15	15		4	34
M	4	19	1			24

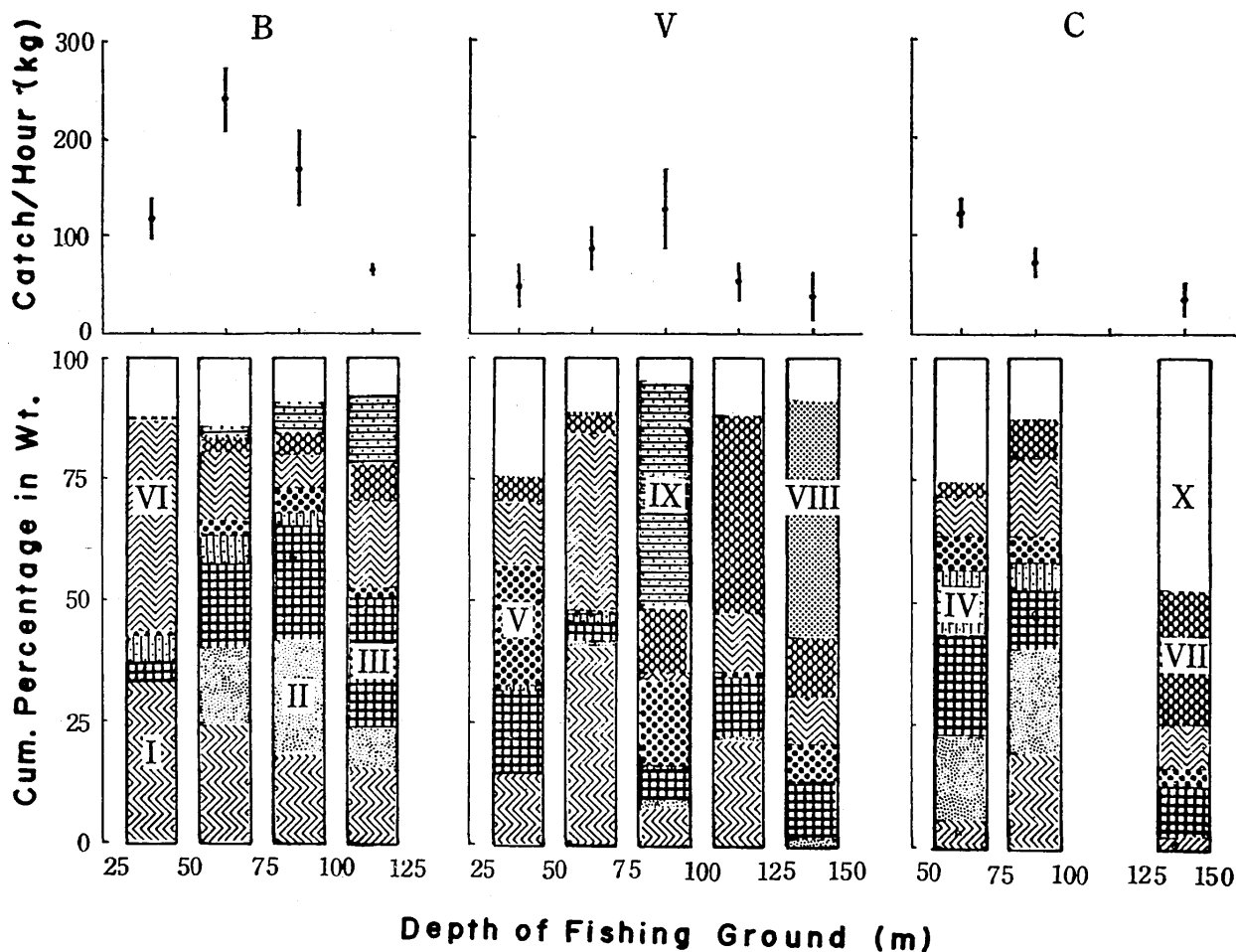

Fig. 2 Variation in trawl catches in the South China Sea by depths.

Top: mean catch per hour and its 70% confidence limits.

Bottom: species composition of catch. I, red snappers; II, bigeye snapper; III, threadfin snapper and goatfish; IV, triggerfish; V, jacks and scad; VI, naked-headed sea bream, thick-lip grunt, white snap-

per and grouper; VII, lizardfish; VIII, sea bream; IX, butterfish; X, others.

B, V and C on the top show areas.

3.5 Catch and species composition by depth

Table X illustrates the number of hauls at different depths of 25 m. intervals in all six areas in 1971. It can be seen that the fishing grounds in areas B, V and C covered a wide range of depth while those in areas T, N and M were limited to waters shallower than 75 m. For this reason the study on the relationship between depth and fish catch is based on data collected from areas B, V and C.

The mean catch per hour and their 70% confidence limits by depths and by areas are shown in the upper portion of Fig. 2.

In area B, the best mean catch was obtained at the depth between 51 and 75 m, and the next was at 76–100 m, with no overlap in their confidence limits. At the depth of 101–125 m, the mean was very low and with a very narrow range of confidence limits indicating that every haul made at this depth yielded very poor catch.

In area V, the best catch occurred at depth of 76–100 m, followed by 51–75 m, with overlapping confidence limits. The poorest was at 126–150 m, although its confidence limits overlap those of 26–50 m. and 101–125 m.

In area C, the mean catch was the best at 51–75 m, followed by 76–100 m and 126–150 m, with no overlap in their confidence limits.

The lower half of Fig. 2 shows the species composition of catch. The 20 categories of fish groups as illustrated in Table V are regrouped into 10, by combining 2 or more fish groups whose habitats, sizes, market values, etc. are roughly the same, and by lumping together fish which did not occur in significant abundance in areas B, V and C into the category "others" (designated as X in Fig. 2).

The depth at which red snappers (I) showed the highest percentage differed by areas, although the absolute abundance of the fish, which is a product of the catch per hour and the percentage of the fish at each depth, was the highest at 51–75 m in areas B and V and at 76–100 m in area C. Almost no red snapper was caught in waters deeper than 126 m.

Naked-headed sea bream, thick-lip grunt, white snapper and grouper are collectively designated as VI in Fig. 2. The variation in the percentage of the group by depths was almost parallel with that of red snappers.

Bigeye snapper (II) did not occur at the shallowest depth and very few were captured in depths exceeding 125 m. The fish was abundant in the waters between 51 and 100 m. deep, although in area V the catch was negligible at any depth.

Threadfin snapper goatfish (III) and jacks and scad (V) occurred over the whole range of depth, and it is rather difficult to point out a general tendency of the variation in the percentage by depths.

Triggerfish (IV) was most abundant at depth between 51 and 75 m. and were not found at depth exceeding 100 m.

Lizardfish (VII) occurred over the whole range of the depth with a clear tendency of being distributed most

abundantly at depth between 101 and 125 m.

Butterfish (IX) was caught over a depth range between 51 and 125 m. in area B and between 76–100 m. in area V. It is likely that the center of distribution of this fish is at the depth between 76 and 100 m.

Sea bream (VIII) consisted of two species which showed quite different distributions. *Taius tumifrons* was obtained only at depth between 126 and 150 m. in area V, occupying nearly 50% of total catch. On the other hand, *Argyrops spinifer*, though not abundant, occurred exclusively at depth between 51 and 75 m.

4. CHANGE IN TRAWL CATCH AT AN INTERVAL OF TEN YEARS

Ten years preceding CHANGI's trawl survey, intensive experimental trawl operations in the South China Sea were carried out by the research vessel HAI-CHING of Taiwan Fisheries Research Institute. In order to clarify if any significant change occurred in the trawl catch during this ten year period, the results of experimental trawling by HAI-CHING in 1960–1962 were compared with those by CHANGI in 1970–1972 as follows.

4.1 Data used

Tseng (1962) reported the results of investigations of HAI-CHING for 1954 and 1960–1962, of which the 1960–1962 data were utilized here. As the names of fishes in the report was written in Chinese¹⁾ and with no mention of trawling time per haul Wei's report (1961) on the 1960 operations was also referred to.

HAI-CHING is a boat of 157.9 tons with an engine of 380 H.P. The trawl net is of 500 meshes (mesh size is not shown), each 250 meshes on upper and lower seams, and was towed for 3 hours at a speed of 3 knots at each station. The surveyed area is divided into square blocks of 30 miles on each side, and each block is numbered. In Tseng's report, the following items are given by block and by trip: number of hauls, both the best catch per haul and average catch per haul in terms of fish-boxes (a box containing 25 kg. of fish), percentage of each major fish species.

The percentage of each fish species was back-calculated into weight, by consecutive multiplication of number of hauls by average catch (box) by 25 kg. by percentage. The blocks were regrouped into 7 areas, T, N, B, V, C, G, and E, as shown in Fig. 1. Thus catch per hour and percentage of each species in total catch were newly calculated for each area. These were compared with the results obtained by CHANGI the fishing gear of which was already given in 2.1.

Although more than 30 species as a whole are recorded in Tseng's report, usually only several species are named to show the species composition in each block. Instead, such categories as "mixture of high grade fishes", "mixture of medium grade fishes" and "mixture of low grade fishes" occur frequently and with quite high

1) An English translation by Yamamoto (1967) includes some mistranslation of fish names. The most serious among them is taking a red snapper, *Lutjanus erythropterus* (=L. *sanguineus*) as a soldierfish, *Myripristis murdjan*.

Table XI. Number of trawl hauls and catches by areas in 1960–62 by HAI-CHING and in 1970–72 by CHANGI

Item \ Area	T	N	B	V	C	G	E
1960–62							
No. of hauls*	68	3	40	20	25	222	191
Total catch (ton)	2.4	0.12	7.1	2.3	3.7	65.9	59.1
Catch/hour (kg)	118.4	14.0	58.9	38.8	48.8	98.9	87.0
1970–72							
No. of hauls**	241	124	115	39	70	24	0
Total catch (ton)	54.9	25.0	22.9	4.4	8.8	2.5	—
Catch/hour (kg)	151.9	134.4	132.8	75.2	83.8	69.4	—

* trawling time per haul: 3 hours

** trawling time per haul: 1.5 hours on average

Table XII. Comparison of species composition of trawl catches during 1970–72 by areas with those of ten years ago.

Species	Area	T		B		V		C		G	
	Year	60–62	70–72	60–62	70–72	60–62	70–72	60–62	70–72	60–62	70–72
		%	%	%	%	%	%	%	%	%	%
Red snapper		6.7	23.0	9.9	22.9	42.8	19.2	4.2	12.4	15.0	26.0
Big-eye snapper		1.2	14.7	14.2	13.0	0	1.1	19.1	11.5	2.7	1.6
Threadfin snapper		2.8	7.8	12.8	6.0	0	3.9	24.6	7.8	4.4	2.9
Goatfish		17.4	3.9	6.4	5.6	0	4.4	2.1	6.8	15.0	4.5
Jacks and scads		1.8	6.0	9.2	4.8	5.4	11.7	23.3	10.0	7.8	4.4
Thick-lip grunt		2.1	4.4	1.3	6.0	12.9	6.1	0	0.4	0.5	2.4
Lizardfish		1.8	3.9	3.5	2.4	5.4	14.6	0.7	7.8	6.5	3.1
Catfish		7.3	3.2	1.4	3.4	0	0	3.4	2.7	4.2	0.7
Grouper		0.3	2.0	0	2.7	0	2.6	0	1.7	1.0	0.7
Shark		0.2	1.9	3.2	2.5	1.1	2.2	1.4	7.9	1.1	0.5
Others		58.4	29.2	38.1	30.7	32.4	34.2	21.2	31.0	41.8	52.6

percentages, suggesting that those which may or may not otherwise be named are put in one of these categories when a catch of the fish in an individual haul was less than 25 kg. For this reason, only 10 species were comparable between the data by HAI-CHING and those by CHANGI.

4.2 Comparison of catch per hour

Table XI shows the number of hauls, total catch and catch per hour by area in 1960–62 and in 1970–72. As only 3 hauls were made in area N in 1960–62 and no hauls in area E in 1970–72, these 2 areas are excluded hereafter.

Except area G, catch per hour was always higher in 1970–72. The difference in catch per hour was biggest in area B (2.3 times) and smallest in area T (1.3 times). Only in area G, catch per hour was 1.4 times more in 1960–62 than in 1970–72.

Table XIII. Coefficient of correlation in ranking of ten species between 1960–62 and 1970–72 by areas

Area	T	B	V	C	G
Coef. Correl.	0.321	-0.068	0.782	0.697	0.855

4.3 Comparison of species composition

Percentages occupied by each of 10 species in total catch in 1960–62 and in 1970–72 are shown in Table XII.

A remarkable difference in species composition between 1960–62 and 1970–72 was seen for all areas except area G. Red snapper occupied a much lower percentage of the total in 1960–62 than in 1970–72 except only area V. In 1960–62 this species comprised less than 10% of total in areas T, B and C, although the percentage of the fish was very high in area V and rather high in area G. On the other hand in 1970–72, red snapper usually occupied nearly or more than 20% in all areas except area C where the fish even comprised 12.5%. Percentage of bigeye snapper by area was in a very good accordance between both periods for most areas, although the fish showed a much lower percentage in area T in the former years than in the latter. The other fishes also showed more or less differences in percentage between both periods as seen in Table XII. Among them, grouper which comprised 1.7–2.7% of total in areas B, V and C in 1970–72 is not recorded in these areas in 1960–62.

Table XIII shows the coefficient of correlation in ranking of the ten species between 1960–62 and 1970–72 for each area, for the purpose of examining the similarity of the species composition between both

periods.

Although the coefficients of correlation in ranking were high in areas V, C and G, those in areas T and B were very low, suggesting almost no similarity between 1960–62 and 1970–72 in the latter two areas.

5. DISCUSSION

5.1 Evaluation of the surveyed areas as trawl fishing ground

From the results given in 3.1, areas T and B may be regarded as promising fishing grounds, although the average catch per hour (150–177 kg/hr) cannot be considered as high, as compared, for instance, with the catch per hour (259–690 kg/hr) in the fishing grounds in north Andaman Sea (Senta and Tan, 1973). However, in the present study, the trawl operations were not concentrated on any one special section of each area, because the main aim of experimental trawl operation by CHANGI has been to cover as wide an area as possible in order to get an overall knowledge of distribution of trawl fishery resources. Therefore, it is believed that the mean catch can be increased further if commercial trawl operations are focussed only on certain sections of each area where good catch was obtained.

The maximum catch per hour may be roughly assessed from the following facts. The best catch of a single haul ever experienced by CHANGI was 1081 kg. (1070 kg/hr) at 02°30'N, 104°50'E on January 20, 1972. Catfish predominated the catch (87% of total). The second best catch was 889 kg. (523 kg/hr) at 04°07'N, 111°49'E on October 20, 1971. Red snappers occupied 54% of the catch, and white snappers 9%. On that day 5 operations were made in an area of 10 miles by 20 miles around the above mentioned point, giving the mean catch of 312.5 kg/hr with C.V. of 56%. The third best catch was obtained at 03°02'N, 104°42.5'E on December 1, 1971, with the catch of 504 kg/hr. Red snapper made up 19% of the catch, and several other fishes of good market value collectively occupied 38%.

Even in area V where the catch per hour was extremely low, it is not impossible to exploit payable fishing grounds. That the value of coefficient of variation in area V was very high suggests that the distribution of fishes in this area was very contagious, showing high densities of fishes in some special parts.

The central or deeper parts of the south-western South China Sea (area C) seems to be less promising, because not only was the catch per hour low but also the value of coefficient variation was rather moderate. Therefore, good fishing grounds in this area, if any, must be limited.

With regards to average catch per hour by depth in the South China Sea, it is still too early to draw any conclusion as the available data is far from sufficient. However, it can be said that good fishing grounds are generally found in waters of depths 51–100 m. The catch at this depth is not only reasonable, but also of good market value. Highly valued fish such as red snappers, white snapper, grouper, naked-headed sea bream, make up a considerable part of the catch.

The distribution of fishes, or the formation of fishing

grounds, may not be affected only by depth itself. Topography and quality of the sea bottom, distribution of the water masses and currents along the sea bottom, together with the biological environment (existence of corals, large sized sponges, etc., abundance of food organisms) are important factors in the formation of fishing grounds.

Studies on ecology as well as behaviour, habitat and feeding habit of fishes on the tropical Pacific Ocean have been published by Hiatt and Strasburg (1960), Randall and Brook (1960) and Helfrich et al. (1968). However, such studies were carried out on the coral reefs in the central Pacific Ocean and consequently in shallow waters. Except for a report concerned with commercial fishes in the Tonkin Bay by Vien (1968), which referred briefly to individual species, there is almost no report on ecological aspects of commercial bottom fishes in the South China Sea.

In order to understand the mechanisms of fishing ground formation, the urgent need for the ecological studies of demersal fishes in the South China Sea cannot be over-emphasized. Similarly, as mentioned in 3.3, since there is a considerable seasonal fluctuation in catch per hour and species composition in areas where the annual fluctuation of oceanographic factors is rather limited in comparison with sub-tropical or temperate seas, a more detailed knowledge of the seasonal shift of fishing grounds is needed before stable and economic catches can be predicted for trawl fishery in these areas.

5.2 Important commercial fishes for trawl fishery

Most species of commercial importance are listed in Tables III, IV and V. Among them, red snappers are the most important from the viewpoints of both quantity and market value. Bigeye snapper, threadfin snapper, jacks and scad, etc. are also caught in large numbers. Naked-headed sea bream, thick-lip grunt, white snapper, grouper, etc. are also main objects of trawl fishery because of good market demand. However, red snappers are not as important in the shallow areas of coastal waters as golden snapper and some small sized species such as croaker and shad.

Commercial ichthyofauna in areas V and M are considerably different from those of the other areas. In area V, lizardfish and butterfish constitute a large part of trawl catch. While sea bream (*Taius tumifrons*) is one of the important species of trawl catch in the East China Sea, it has not been caught in the surveyed areas except in area V. This suggests that some members of ichthyofauna of area V may have migrated from the higher latitude and which in turn implies that the seasonal fluctuation of catch and species composition in area V may be larger than in the other areas.

Although triggerfish occupies a high percentage in trawl catch in all the areas except area V, it has little economic value at present. In some Southeast Asian countries, this species is treated as scrap fish (Anonymous, 1967). Threadfin (*Polydactylus*), one of the most expensive fishes in the Southeast Asian countries, has never been caught by CHANGI. It appears that the distribution of the fish may be restricted to shallower and less saline waters with muddy bottom.

5.3 Trend of demersal fish resources

As far as the data is concerned, catch per hour in 1970–72 was higher than that in 1960–62 in 4 areas out of 5 areas examined, thus superficially suggesting that resources for trawl fishery have increased during this ten years' time. However, fishing efficiency of HAI-CHING and CHANGI may be different, since the factors affecting it may differ by boat as has been mentioned earlier. Furthermore, the catch per hour in each area is to certain extent subject to a seasonal fluctuation, and some areas were operated by the two vessels in different seasons.

Therefore, the results presented in 4.2 may indicate the trend of demersal fish resources only approximately. So, it may be safer to say that the resources for trawl fishery in the surveyed areas of the South China Sea in 1970–72 were almost at the same level as those in 1960–62. As for area G (Gulf of Thailand), it may be probable that fisheries resources have been decreasing due to the recent rapid increase in fishing effort of Thai trawlers.

The difference in species composition between both periods was very remarkable except in area G, although the coefficients of correlation in ranking of the ten species were rather high in areas V, C and G. Even supposing that this result reflects actual changes in demersal ichthyofauna, they are rather desirable ones. Because, the percentages of esteemed fishes such as red snapper, thick-lip grunt and grouper had become higher in almost all the areas. Besides the above 3 species, white snapper and naked-headed sea bream which comprised only 0.3% and 0.03% of total catch in 1960–62 (all areas combined) usually occupied about 4% and 5% of total catch in 1970–72, respectively, although these fishes are put into "others" in Table XII.

It is, however, considered that this difference in species composition is also superficial to some extent. As mentioned in 4.1, very few fish species were named in the trawl catch obtained in many individual blocks by HAI-CHING. Most of them were grouped in the category "mixture". White snapper, naked-headed sea bream and triggerfish are recorded only in 4, 1 and 1 blocks respectively in Tseng's report, although these constituted frequent and abundant species in the trawl catch by CHANGI. From these facts, it may not be erroneous to judge that these species and sometimes even red snapper, thick-lip grunt and grouper are included in "mixture of high grade fishes" or in "mixture of medium grade fishes". The difference in the type of trawl net by boat might have also affected the species composition of catch.

To conclude, there is no evidence to consider that any drastic change had occurred in resources for trawl fishery in the South China Sea during the period from 1960 to 1972. The change, if any, may be a rather desirable one.

5.4 Utilization of discarded fish

Non-marketable fish caught by CHANGI were discarded on the spot. Except in area M, the discarded fish normally constituted only about 10% of the total catch. On a few occasions, particularly in shallow waters, the discarded fish were caught in large quantities, and at times exceeding the catch of marketable fish. Such a case was

observed in area M in July 1971 when the discarded fish were 1.4 times the amount of marketable fish.

According to the result of the joint Thai-Malaysian-German trawl survey along the east coast of the Malay Peninsula (Anonymous, 1967) the ratio of scrap fish to food fish was about 3:5. In their study, leiognathids and gerrids were regarded as fish suitable for human consumption while triggerfish were considered as scrap fish. However, in CHANGI the former two species were discarded and the latter was landed.

Silverbelly (*Leiognathus*) and silver-biddy (*Pentaprion*) were the commonest and most abundant discarded species of CHANGI. These fishes were regarded as food fish in Thailand and Malaysia, and they are valuable material for making fish sauce in Vietnam (Vien, 1968). It has been suggested that these fish may serve as bait for tuna fisheries, either frozen for tuna long line or live for pole and line, as well as bait for bottom long line.

5.5 Future investigations

Very little has been published on the fishery biology of demersal fish in the region. In order to establish a suitable trawl fishery and the management of fishery resources of the Southeast Asian region, some aspects of fishery biology such as spawning, growth, migration, habitat, population density, etc. need to be considered. However, priority should be given to the economic studies of the most appropriate size of fishing boat and fishing techniques for the exploitation of the various fishery resources in the region. These must be considered objectively, using experimental catch data and the actual market condition and demand in each member country.

6. ACKNOWLEDGEMENTS

The authors express their hearty gratitude to Mr. T. Hirota, captain, Mr. C. Miyata, masterfisherman and all the crew staff of R/V CHANGI who carried out the experimental trawl fishing. The authors are indebted to all the research scientists of Research Department, SEAFDEC, who engaged in the research work on board CHANGI.

Many thanks are due to Mr. Chen Foo Yan, chief of the Research Department for his critical reading of the manuscript and kind advices.

Literature cited

- Anonymous. 1967. Results of the joint Thai-Malaysian-German trawling survey off the east coast of the Malay Peninsula, 1967: 1–64. Report prepared by the Marine Fisheries Laboratory of Thailand and Fisheries Research Institute of Malaysia.
- Helfrich, P., et al. 1968. Ciguatera fish poisoning. I. The ecology of ciguateric reef fishes in the Line Islands. Occas. Pap. Bernice P. Bishop Mus. 23: 305–369.
- Hiatt, R. W. and D. W. Strasburg. 1960. Ecological relationships of the fish fauna on coral reefs of the Marshall Islands. Ecological Monogr. 30:65–127.
- Morisita, M. 1959. Measuring of interspecific association and similarity between communities. Mem. Fac. Sci. Kyushu Univ., Ser. E (Biol), 3:65–80.

- Randall, J. E. and V. E. Brock. 1960. Observations on the ecology of epinepheline and lutjanid fishes of the Society Islands, with emphasis on food habits. *Trans. Am. Fish. Soc.* 89:9-16.
- Senta, T. and Sen-min Tan. 1973. Trawl fishing grounds in north Andaman Sea. Paper to SEAFDEC Seminar, May 1973, Bangkok. pp.
- Tseng, Chan-tang. 1962. Report of catch record by fishing area in trawl fishing ground in the South China Sea. *Taiwan Fish. Res. Inst., Fish. Invest.* (28):1-11 (in Chinese)
- Vien, L. M. 1968. Commercial ichthyofauna of the Tonkin Bay. *Voprosi Ikhtiologii*, 8:817-833. (Russian with English title).
- Wei, Shu-fun. 1961. Report of investigation on trawl fishing ground in the South China Sea in 1959 fiscal year. *Bull. Taiwan Fish. Res. Inst.*, (7):95-146. (in Chinese).
- Yamamoto, T. 1967. Report on experimental trawl fishing in South China Sea. *IPFC Occas. Paper.* 67/11:1-24. (English translation of Tseng, 1962).

SEAFDEC/SCS.73: S-11

Studies on the Feeding Habits of Red Snappers,
Lutjanus Sanguineus and *L. Sebae*

by
Tetsushi Senta and Che-Chun Peng¹⁾

Marine Fisheries Research Department
Southeast Asian Fisheries Development Center

Abstract

Examination of stomach contents were carried out on 276 *Lutjanus sanguineus* and 129 *L. sebae* in an attempt to study the feeding habits of the two commercially important demersal fishes occurring in the southern South China Sea.

The studies show that although their feeding habits are rather flexible, their diet consists mainly of fishes, crustaceans (especially crabs and stomatopods) and cephalopod molluscs. The result of the present study is in general agreement with the diet of other *Lutjanus* species from different areas as reported by some workers. However, the data presented here are rather different from the diet of *L. sanguineus* in the Tonkin Bay (Vien, 1968)

The feeding habits of both species are well suited for a demersal life, and they occupy the highest niche in the bottom ichthyofauna in the South China Sea.

The reaction between the regurgitation rate and the depth of the fishing ground as well as the regression of stomach length against the total length of fish were also determined.

1. INTRODUCTION

Red snappers hold a very important position in the trawl fisheries particularly in the South China Sea, usually occupying more than 20% of the total catch. Among the red snappers belonging to the genus *Lutjanus*, *L. sanguineus* (Cuvier et Valenciennes) is the most important, often exceeding 70% of all red snappers caught by trawl (Kungvankij, 1971). Its usual size in trawl catch is between 55 and 70 cm in total length and 2 and 4 kg in body weight. *L. sebae* (Cuvier et Valenciennes) is of second importance. Although its average total length is about the same as *L. sanguineus*, it is heavier because of its relatively deeper body.

1) Present address: 132-4, Lorong Ladi Padi, Singapore 26

While there is considerable literature on ichthyofauna and trawlfisheries of the South China Sea and its adjacent waters, very little deals with the biological and ecological aspects of commercially important fishes. Vien (1968) referred briefly to the feeding habit of *L. erythropterus* Bloch (= *L. sanguineus*) in the Tonkin Bay while Helfrich et al (1968) and some other workers reported the feeding habits of some other species of the genus. In view of the limited information the Marine Fisheries Research Department of the Southeast Asian Fisheries Development Center has drawn up a program to study the various biological aspects of economically important demersal fishes in the Southeast Asian region. The present paper deals with the feeding habits of the two red snappers.

2. MATERIALS AND METHODS

The material fish were collected by the research vessel CHANGI during the period between April and September, 1971, in the southern part of the South China Sea. The stomach contents of 276 *sanguineus* and 129 *sebae* were examined. The stomach was exposed by making a mid-ventral incision in the body wall, usually within 15 minutes after the catch was emptied onto the deck. The stomach was cut off anteriorly from the esophagus and posteriorly from the intestine behind the pyloric valve, removed and tightened at both ends. To each stomach, an index number was attached with thread and preserved in 10% formalin solution to prevent any further digestion and decomposition of the contents. The total length, body weight, sex, sexual maturity of the fish were recorded together with the catch record. Any other non-marketable organisms caught with the fishes as well as parasites infestation were also noted.

Examination of the stomach content was done in both the laboratory and on board CHANGI. After dissecting, the content of the stomach was discharged into a glass

dish and the number and weight of each food item were recorded.

Since age or size may be a factor to be considered in the study of the feeding habits of fish, specimens of *sanguineus* and *sebae*, ranging from 10 to 80 cm in total length, were classified into seven size groups of 10 cm interval.

3. RESULT

3.1 Food organisms of *L. sanguineus*

Fig. 1 shows the relative importance of various food categories found in *L. sanguineus* by size groups. The upper half of the figure shows the frequency of occurrence of important food items in the stomachs of fish of each size group. As illustrated in the figure, fish and crabs occurred most frequently in all size groups. Stomatopods were also common although the frequency was not high, while molluscs and ascidian were observed in the stomachs of the two largest size groups. However, shrimps had a surprisingly low frequency of occurrence except in the 20–30 cm size group. Although the presence of shrimp is not shown in the figure its 26.3% frequency of occurrence is considered high.

The lower half of Fig. 1 shows the weight composition

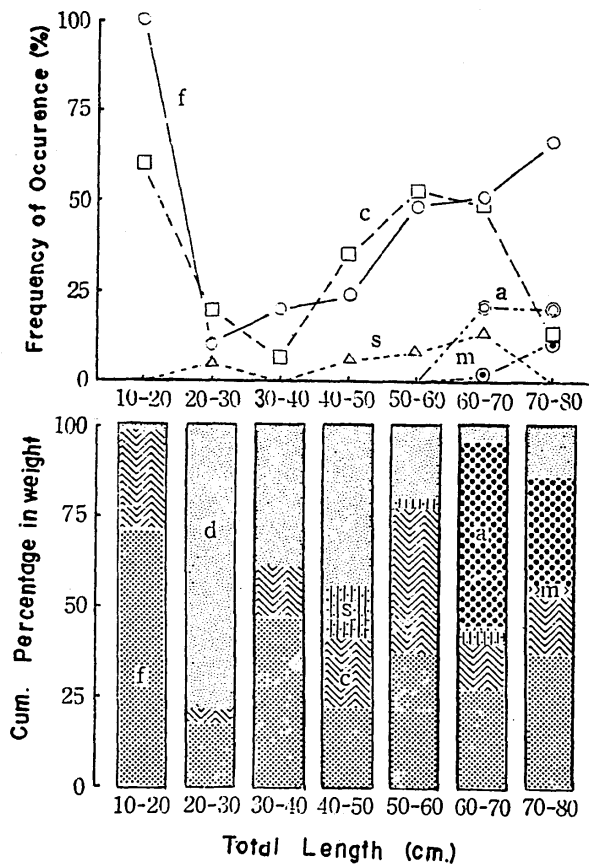

Fig. 1 Relative importance of main food categories in *L. sanguineus* by size groups as expressed by frequency of occurrence (top) and percentage in weight (bottom) of each category. a: crab, d: digested food, f: fish, m: mollusk, s: stomatopod.

of the stomach content in the form of cumulative percentage. Digested food organisms which were impossible to identify often occupied a larger part of the stomach content. Apart from digested food, fish usually predominated as shown by the high value of 72% in the size group of 10–20 cm. Even in the next size group in which 17% of the content was made up of fish by weight the actual percentage of fish as a food item must be higher, since a considerable part of the “digested food” must have been composed of fish. Crabs were next in importance especially in the 50–60 cm size group. Stomatopods occupied a rather significant part of the stomach content in the size group of 40–50 cm, and were of some significance in the subsequent two groups. An ascidian, *Botrylloides* sp., occurred in a surprisingly high percentage in the stomach content of the two biggest size groups. It is, however, a little doubtful whether this species actually constitutes an important part of the food organisms for *L. sanguineus*, since this food item occurred only in the stomachs taken from a single locality during September. Molluscs, composed of *Sepia* and *Loligo* species, showed only a very low percentage in weight in the bigger size groups. Although the frequency of occurrence of shrimp was considerably high at least in the second size group, their individual weights were so small that its percentage in weight was negligible. Some other categories of food items such as anomura, coelenterate, etc. also occurred, but with very low values of frequency of occurrence.

The following species, arranged according to their relative importance by weight, constituted the category “fish” of the food items of *L. sanguineus*: *Caranx leptolepis* (cuvier et Valenciennes), *Priacanthus tayenus* Richardson, *P. macracanthus* Cuvier, *Saurida undosquamis* (Richardson), a fish of Carangidae, *Nemipterus hexadon* (Quoy et Gaimard), *Trachurops* sp., a fish of Tetraodontidae, *Decapterus* sp., *Caesio chrysozonus* Cuvier et Valenciennes, *Nemipterus* sp., *Saurida* sp., a fish of Monacanthidae, *Saurida tumbil* (Bloch), *Leiognathus* sp., *Upeneus* sp., *Apogon* sp., *Clupea* sp., *Caesio* sp., *Stephanolepis* sp., and some unidentified fishes. As for crabs, the following species were found in the stomachs of the fish; *Charybdis helleri* A. Milne-Edwards, *Portunus pseudoargentatus* Stephenson, *Liagore rubromaculata* de Haan, *Portunus* sp., *Eucrate* sp., *Demania scaberrimus* (Walker), *Charybdis miles* de Haan, *Portunus argentatus* White and *Phalangipus longipes* (Linne); and as for stomatopods; *Carinosquilla carinata* (Serene) and *Harpisquilla annandalei* (Kemp). All crustacean specimens were identified by Dr. R. Serene, the UNESCO expert to Singapore, to whom the present authors express their sincere gratitude.

3.2 Food organisms of *L. sebae*

The main food items found in *L. sebae* (Fig. 2) were nearly the same as in *sanguineus*. Fish, crabs, stomatopods and molluscs constituted the stomach content of the fish. Fish and crabs usually occupied the top positions in frequency of occurrence, although no fish occurred in the second size group. Frequencies of occurrence of stomatopods and molluscs were generally much higher than in

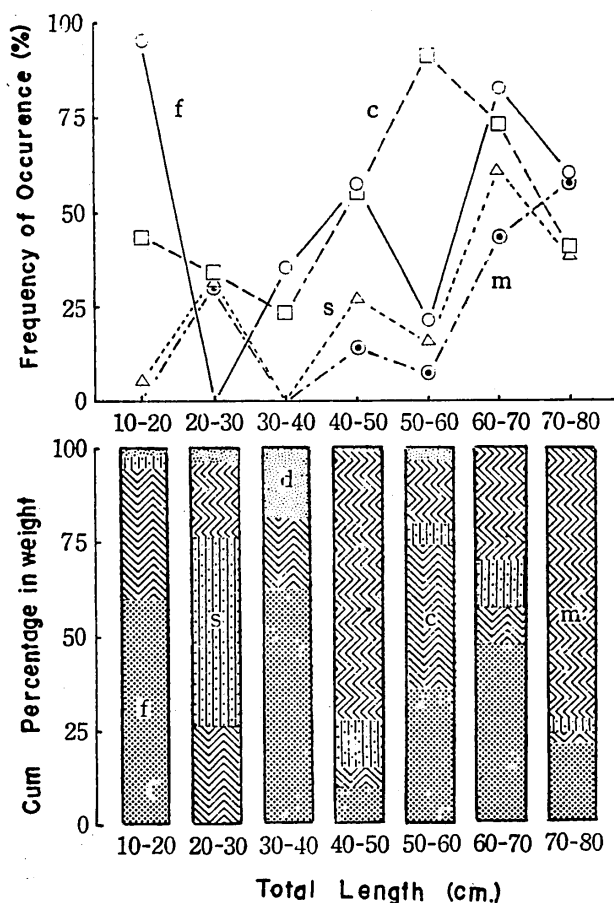

Fig. 2 Relative importance of main food categories in *L. sebae* by size groups as expressed by frequency of occurrence (top) and percentage in weight (bottom) of each category. c: crab, d: digested food, f: fish, m: mollusk, s: stomatopod.

sanguineus.

In *sebae*, the percentage of digested food was very low. In four size groups out of seven, fish occupied the largest part of the stomach content. Unlike *sanguineus*, molluscs showed much higher percentage in weight, occupying more than 70% of stomach content in the size groups of 40–50 cm and 70–80 cm. Crabs and stomatopods were also of considerable importance.

The category "fish" of the food items of *L. sebae* includes the following species: *Nemipterus* sp., *Synodus hoshinonis* Tanaka, *Upeneus tragula* Richardson, *Samaris cristatus* Gray, *Decapterus* sp., *Apogon* sp., *Upeneus bensasi* (Temminck et Schlegel), a fish of Tetraodontidae, *Samaris* sp., a fish of Carangidae, *Trichiurus* sp., *Upeneus* sp., a fish of Balistidae, a fish of Monacanthidae, *Aluterus monoceros* (Linné), a fish of Mullidae, a fish of Pleuronectida and some unidentified fish. Crabs which were found in the stomachs of *L. sebae* were as follows (asterisks after certain species show that those crabs were also ingested by *L. sanguineus*): *Portunus* sp., **Charybdis helleri*, **Podophthalmus vigil* (Fabricius), *Charybdis* sp., *Myrodes eudactylus* Bell, *Charybdis miles*, **Portunus pseudoargentatus*, **Charybdis natator* (Herbst), *Cycloes granulosa* de Haan, *Eucrater* sp., **Arcania novemspinosa* Adams et White, *Charybdis feriatus* (Linne) and *Phalangipus*

*longipes**; and as for stomatopods: *Harpisquilla annandalei*, **Odontodactylus cultrifer* (White), *Lysiosquilla maculata* (Fabricius) and *Oratosquilla gonypetes* (Kemp).

3.3 Regurgitation Rate

One of the difficulties in the study on feeding habit of bottom fishes lies in the fact that the stomachs of a contents are completely regurgitated on surfacing. Thus, in the present study, the fish caught were examined first by opening the mouths and only those fish with the stomachs of an ordinary condition were used as study materials. The regurgitation rate in *L. sanguineus* suddenly increased as the depth of the fishing ground exceeded 65 m. On one occasion, the regurgitation rates were determined for fish caught at various depths. The rates were 0% at 33 m, 31% at 64 m, 58% at 70 m, 78% at 88 m and 89% at 139 m. However, such a phenomenon was not found in the case of *L. sebae*.

3.4 Stomach length-body length

The relationship between stomach length and body size was also studied for both species. Such a study is necessary for our purpose especially when stomachs of fish of unknown body length are collected from fish canneries or fillet factories.

The total length of fish and stomach length were measured for 42 *L. sanguineus* (Total length ranging 17–76 cm) and 23 *L. sebae* (12–63 cm). The regressions of stomach length (SL) against total length (TL) for both species were determined by the method of least squares. In general, the regression line fitted the data quite well. In *sanguineus*, the relative stomach length was greater than in *sebae*. The regression lines obtained for *sanguineus* and *sebae* were $SL = 0.153 TL + 6.1$ (mm) and $SL = 0.148 TL + 5.0$ (mm) respectively.

4. DISCUSSION AND CONCLUSION

The diet of both *L. sanguineus* and *L. sebae* was not restricted to some special food items; rather, they seemed to feed on almost every kind of organisms inhabiting the bottom. The fluctuation in the relative importance of each food item for the various size groups of the predators may, to some extent, be attributed to the insufficiency of the number of fish examined. Nevertheless, it may be safely concluded that the food items of both species of red snappers are mainly composed of fish, crabs, stomatopods and molluscs. *L. sebae* feed on crustaceans and molluscs more intensively than *L. sanguineus* as shown in Figure 2. While more fish species were found in the stomachs of *L. sanguineus*, more crab and stomatopod species occurred in *L. sebae*, even though the number of *sanguineus* examined was more than twice that of *sebae*. Their feeding habits may be considered as quite flexible — even ascidians were found in great quantity in one case.

The feeding habit of *L. sanguineus* in the Tonkin Bay seems to be rather different from the result obtained in the present study. According to Vien (1968), adult individuals in the bay feed mainly on fishes. Neither crabs, stomatopods nor molluscs are important food items,

although the young are reported to feed on shrimps and small fishes, and occasionally on squids.

The diet of other species of *Lutjanus* such as *L. bohar* (Forskål), *L. gibbus* (Forskål), *L. vaigiensis* (Quoy et Gaimard), *L. kasmira* (Forskål), *L. monostigmus* (Cuvier et Valenciennes), *L. griseus* (Linné) and *L. argentiventris* (Peters) from various areas of the tropical Pacific, Indian and Atlantic Oceans has been reported (Longley et al. 1925; Londley & Hilgebrand, 1941; Randall, 1955; Randall & Brock, 1960; Hiatt & Strassburg, 1960; Talbot, 1960; Hobson, 1965; Helfrich et al. 1968). The diet of most of these species is also mainly composed of fishes, crabs, stomatopods and molluscs. Helfrich et al. (1968) classified *L. bohar* and *L. gibbus* in the Line Islands as a euryphagous roving carnivore and a roving, unspecialized carnivore, respectively. Among the food organisms of *L. bohar* in the Line Islands, decapod crab megalops formed the dominant item of crustaceans, especially from November through May, and gastropods made up a larger part of molluscs. These two groups, megalops and gastropods, scarcely occurred in the stomachs of both *L. sanguineus* and *L. sebae*.

Significance of ascidians as a food item has not yet been reported for *Lutjanus* species, although tunicates were important food items for some species of West Indian reef and inshore fishes (Randall & Hartman, 1968).

In the present study, no evidence of cannibalism among *L. sanguineus* or *L. sebae* was found. The present authors have also carried out the study on the feeding habit of 11 other species including several piscivorous fishes such as *Saurida tumbil* (Bloch), *S. undosquamis* (Richardson) and *Rachycentron canadum* (Linne). Neither *L. sanguineus* nor *L. sebae* was found in their stomachs. Therefore, the natural mortality of both species due to the predatory activity of enemies seems to be rather low. Cannibalism does not seem to take place also among lutjanids in the Line Islands. Out of 1790 *L. bohar*, only 2 individuals were found ingesting some unknown species of lutjanid. A possible predator of lutjanids is grouper, since one specimen out of 14 *Epinephelus hexagonatus* (Bloch et Schenider) examined in the Line

Islands contained the remains of a *Lutjanus* species (Helfrich et al., 1968).

Summarizing, it may be said that the feeding habits of both *L. sanguineus* and *L. sebae* are well suited for a demersal life, and both species occupy the highest niche in the bottom ichthyofauna in the South China Sea.

References

- Helfrich, P., T. Piyakarnchana and P. S. Miles. 1968. Ciguatera fish poisoning. I. The ecology of ciguateric reef fishes in the Line Islands. Occas. Pap. Bernice P. Bisho Mus. 23:305-369.
- Hiatt, R. W. and D. W. Strasburg. 1960. Ecological relationships of the fish fauna on coral reefs of the Marshall Islands. Ecological Monogr. 30:65-127.
- Hobson, E. S., 1965. Diurnal-nocturnal activity of some inshore fishes in the Gulf of California. Copeia 1965, (3): 291-302.
- Kungvankij, P., 1971. Biological study of red snapper *Lutjanus sanguineus* (Cuvier et Valenciennes). Graduation thesis, Research Dept. S.E. Asian Fish. Develop. Center.
- Longley, W. H. and S. F. Hildebrand. 1941. Systematic catalogue of fishes of Tortugas, Florida. Carnegie Inst. Washington Monogr. 535 (Tortugas Laboratory Pap., vol. 34).
- Longley, W. H., W. L. Schmitt and W. R. Taylor. 1925. Observations on the food of certain Tortugas fishes. Carnegie Inst. Washington Pub. 34.
- Randall, J. E., 1955. Fishes of the Gillbert Islands. Atoll Res. Bull. No. 47. Washington, D. C. Pacific Sci. Bd., Nat. Res. Council.
- Randall, J. E. and V. E. Brock. 1960. Observations on the ecology of epinepheline and lutjanid fishes of the Society Islands, with emphasis on food habits. Tans. An. Fish. Soc. 89:9-16.
- Randall, J. E. and W. D. Hartman. 1968. Sponge-feeding fishes of the West Indies. Marine Biol. 1:216-225.
- Talbot, F. H. and Notes 1960, on the biology of the Lutjanidae, with special reference to *Lutjanus bohar*, (Forskål). Ann. S. Afr. Mus. 45:549-573.
- Vien, L. M. 1968. Commercial Ichthyofauna of the To-kin Bay. Vop. Ikhtiol. 8:817-833. (in Russian).

SEAFDEC/SCS.73: S-12

Trawl Fishing Grounds in North Andaman Sea

by

Tetsushi Senta and Sen-Min Tan

Marine Fisheries Research Department
Southeast Asian Fisheries Development Center

Abstract

Experimental trawl operations in north Andaman Sea were carried out by three vessels, T/V JURONG from the Singapore Fisheries Training Center, T/V PAKNAM and

R/V CHANGI from SEAFDEC, from 1971 to 1973.

The results of catch analysis show that the fishing ground is promising. Means of catch per hour ranged from 260 to 690 kg. for the 8 survey cruises, among which 3 cruises yielded more than 500 kg/hr. Croaker, catfish,

jacks and scad, shad, golden snapper, grunter and white pomfret usually constituted about 70% of total catch. However, catch per hour and species composition varied, sometimes extremely, from haul to haul, suggesting patchy distributions of fish schools.

Good fishing grounds were usually found in shallow waters of 30–40 metres deep, and means of catch per hour decreased with depth. Nevertheless the mean of catch per hour in the deepest waters surveyed (60–80 metres) was at the same level as those observed in the good fishing grounds in the South China Sea. On the other hand, fluctuation of catch per hour was much higher in shallow waters than in deeper waters.

1. INTRODUCTION

The FAO/UNDP Fisheries Training Center, a joint project with Singapore, carried out trawl surveys in north Andaman Sea in December 1971 and January 1972. The results were promising. In order to study the fishing ground in greater detail a joint survey between the two departments of the Southeast Asian Fisheries Development Center (SEAFDEC) and the Fisheries Training Centre was carried out at the end of 1972. The training and research vessels involved were T/V JURONG of the Fisheries Training Centre, T/V PAKNAM of the Training Department and R/V CHANGI of the Marine Fisheries Research Department. Another joint survey was also carried out by JURONG and CHANGI in January 1973.

2. VESSELS AND FISHING GROUNDS

2.1 Vessels and trawl nets

Table I shows the details of vessels and trawl nets used in the survey. As shown in the table JURONG is smaller in both size of boat and power of main engine than the other two vessels, while the net used by her is much larger than the others. However, this difference was not taken into account in analysis of the catch. As the average trawling time by CHANGI was shorter, the catch of each haul by all three vessels was converted into catch per hour before any further calculation.

2.2 Fishing grounds

The areas surveyed by all three training and research vessels are enclosed by longitude 14–16°N and latitude 94°–97°30'E. However, the trawl operations were concentrated in a few localities, as shown in Fig. 1. For convenience of analysis of the catch data, the fishing grounds were divided into 4 areas (a, b, c, d) in this report.

Table I. Details of the vessels and trawl nets used in the survey

	T/V Jurong	T/V Paknam	R/V Changi
Size of boat (tons)	213.3	386.8	386.6
Power of main engine (HP)	750	1000	1000
Type of net	4 seamed	4 seamed	4 seamed
Size of net in length of head rope (m)	51.5	34.4	36
Trawling speed (knots)	3.5	4	3.5
Trawling time/haul (hrs)	2	2	1.5

3. RESULTS

3.1 Catch per hour

During the period from December 1971 to January 1973, the three vessels made 8 survey cruises and 165 trawl hauls in north Andaman Sea. Because of the prevailing monsoons the most suitable time for operations in these waters is at the beginning and the end of a year. Hence operation surveys were conducted from November to January.

Table II shows the date, the number of hauls and the catch of the trawl operations in north Andaman Sea.

During the survey cruises by JURONG in December 1971 and January 1972, the high total catch and mean catch per hour (more than 650 kg/hr) were obtained, indicating a rich and well matured fishing ground. Although subsequent joint operations carried out in the same areas by the three vessels in December 1972 did not produce such good results, the catches were still high

Table II. Trawl catch by cruise in the fishing ground in north Andaman Sea Both arithmetic and geometric means are shown.

Cruise number	1	2	3	4	5	6	7	8
Month, year	Dec. 71	Jan. 72	Nov./ Dec. 72	Dec. 72 I	Dec. 72 II	Dec. 72 III	Jan. 73 I	Jan. 73 II
Name of boat	J	J	J	J	C	P	J	C
No. of haul	15	20	15	25	13	34	19	24
Total catch (ton)	21.8	27.7	14.0	12.5	6.3	17.1	19.3	13.9
Arith. mean of catch/hr (kg)	656.1	691.2	459.4	258.7	360.7	272.1	548.3	398.2
Coefficient of variation (%)	134	108	69	61	77	61	88	100
Geom. mean of catch/hr (kg)	445.0	448.2	393.3	210.0	259.5	210.4	360.9	301.1
70% confidence limits								
Upper limit	773.8	568.7	455.3	243.4	322.2	239.9	460.8	349.4
Lower limit	255.9	353.3	339.7	181.1	209.1	184.5	282.7	259.6

Abbreviation for name of boat: J: T/V Jurong, C: R/V Changi, P: T/V Paknam

compared to standard catch from the South China Sea (Senta, et al. 1973).

It can be seen from Table II that the coefficient of variations exceeded 100% in 3 cruises (cruises 1, 2 and 8), indicating great fluctuations in catch while the coefficient of variations for the remaining cruises were rather moderate, being almost at the same level as those observed in the South China Sea (Lit. cit.).

From the geometric means of catch per hour and their 70% confidence limits in Table II, it is seen that cruise 2 yielded the best catch, with the lower limit of confidence well above the upper limits of confidence for cruises 4, 5, 6 and 8. On the other hand, values for catch per hour in cruises 4 and 6 were very poor, with the upper confidence limits of geometric mean well below the lower confidence limits for all other cruises. Still, the values for catch per hour for these two cruises were much higher than those for any areas in the South China Sea as surveyed by CHANGI.

3.2 Species composition of catch

3.2.1 Species composition in general

Table III shows that croaker was the predominant fish caught, comprising more than 23% in weight of the catch. Catfish, jacks and scads, shad and grunter were usually abundant although a certain degree of fluctuation in the catch of these fishes was observed. Golden snapper, white pomfret and spanish mackerel also constituted an important part of the catch although they were caught rather sporadically. In contrast to the catch from the South China Sea where red snappers were predominant, their percentage in the catch in this area was less

significant. Also of less importance are threadfin snapper and goatfish which comprised less than 5% of the catch.

3.2.2 Species composition by cruise

Except for one cruise, croaker was by far the most abundant fish caught in this area, especially when the catch per haul exceeded 1 ton. The catch of croaker showed little fluctuation by cruise. However, a certain degree of fluctuation occurred in the catch of catfish, jacks and scad, shad and grunter, although these fishes were caught in nearly every cruise. Golden snapper, white pomfret and spanish mackerel were only caught in some of the cruises. The catch of golden snapper was especially variable. During the January 1973 cruise by JURONG (cruise 7) one haul had a catch of 2.9 tons of golden snapper, while the remaining 5 hauls on the same day yielded only 25–65 kg of the fish.

The fluctuation in catch of white pomfret, a fish of economical importance, was also remarkable. This fish occupied 11.3% and 8.2% of total catch in cruises 3 and 4 while in cruise 7 and 8 their catch was negligible. The distribution of white pomfret must be very contagious, because the fish catch usually fluctuated from haul to haul even within the same area and the same day. For instance, on December 7, 1972 the pomfret caught in each haul ranged from 20 kg to 325 kg.

The occurrence of red snapper in the catch was rather infrequent, and only occurred where operations were carried out in depths of more than 40 metres. This could indicate that red snapper had a different distribution pattern from the other fishes dominant in this area.

Table III. Percentage in weight of major species in total trawl catch by cruise

Cruise Number	Month/year	1	2	3	4	5	6	7	8
		Dec. 71	Jan. 71	Nov./ Dec. 72	Dec. 72 I	Dec. 72 II	Dec. 72 III	Jan. 73 I	Jan. 73 II
1. Croaker		27.8	27.9	39.2	23.6	39.8	23.3	24.2	23.4
2. Catfish		28.2	12.6	11.2	21.3	5.6	15.7	3.1	9.2
3. Jacks & scad		1.0	3.5	3.4	13.9	11.6	8.8	4.4	10.7
4. Shad		12.3	4.1	12.9	1.3	11.4	1.0	4.9	6.6
5. Golden snapper		—	12.5	—	—	0.2	1.3	22.7	14.5
6. Grunter		3.5	21.4	1.6	10.1	1.1	—	7.8	8.0
7. White pomfret		1.4	4.1	11.3	8.2	6.5	2.7	—	0.1
8. Red snapper		2.7	—	1.8	3.7	3.1	3.7	—	—
9. Spanish mackerel		1.6	4.6	0.8	2.6	—	0.3	3.6	0.5
10. Hairtail		1.8	—	0.5	5.1	0.3	2.8	1.5	2.6
11. Lizardfish		0.4	—	—	—	5.9	4.0	0.9	4.1
12. Dorab		0.7	1.4	0.1	1.7	—	0.1	0.8	0.4
13. Conger eel		—	0.7	0.3	1.0	0.6	0.3	0.4	1.4
14. Threadfin snapper		0.6	—	—	2.3	2.8	5.1	—	1.3
15. Mackerel		0.4	0.3	—	—	—	3.3	4.8	—
16. Goatfish		—	1.4	—	—	1.0	3.5	—	1.4
17. Chorinemus		—	—	—	1.2	2.1	0.3	1.3	2.9
18. Seabream		3.0	—	—	—	0.2	—	—	—
19. Barracuda		—	—	—	0.1	—	0.8	—	1.0
20. Sharks & ray		4.1	3.0	5.2	3.7	4.8	6.2	1.8	8.3
21. Other fishes & squid		8.5	2.5	11.7	0.2	3.0	16.8	17.8	3.6

* 1: sciaenids, 2: *Tachysurus*, 3: carangids, 4: *Pellona & Ilisha*, 5: *Lutjanus johni*, 6: *Pomadasys*, 7: *Pampus argenteus*, 8: large-sized lutjanid other than 5, 9: *Scomberomus*, 10: *Trichiurus*, 11: *Saurida*, 12: *Chirocentrus dorab*, 13: *Muraenesox talabon*, 14: *Nemipterus*, 15: *Rastrelliger*, 16: mullids, 17: *Chorinemus*, 18: *Gymnocranius*, 19: *Sphyræna*.

3.3 Catch by area and by depth

Most of the hauls of the surveys were concentrated in areas b and c, especially in shallow waters (Fig. 1). Only 3 hauls each were made in areas a and d. Table IV shows the number of hauls by depth in each area.

The catch per hour distribution in each area is given in Fig. 2. This figure shows clearly that the distribution pattern of the catch per hour in areas b and c are quite similar. Both areas showed a wide range of fluctuation, ranging from about 50 kg/hr to 3500 kg/hr. Area c seems to be slightly better in terms of higher value of catch/hr. However, any difference in the mean catch per hour may be superficial as the number of hauls in each area varies considerably. As there were only 3 hauls each in areas a and d, it is difficult to compare these two areas with area b and c.

Catch per hour as well as species composition varied with depth. As shown in Table V, the highest mean value of catch per hour (509.3 kg) was obtained in depth of 30–40 metres, almost twice that of 40–50 m depth (285.9 kg/hour). In the depth range of 60–80 metres, the catch per hour was only about one-third that of 30–40 metres depth. However, in the waters of depth 30–40 metres, the coefficient of variation was 108%, indicating greater degree of fluctuation than the other depth ranges. The fluctuation of catch per hour decreased greatly as the depth increased.

Table IV. Number of hauls by depth and by area

Area	Depth (m)	Depth (metres)				
		30–40	40–50	50–60	60–70	70–80
a				1	1	1
b		33	16	4		
c		75	28	3		
d				2	1	
Total		108	44	10	2	1

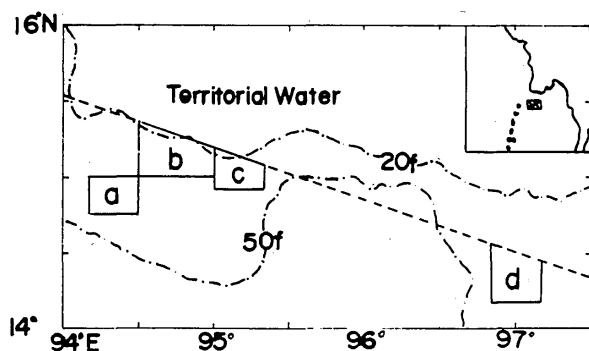

Fig. 1 Map to show the surveyed areas and depth contours in the north Andaman Sea.

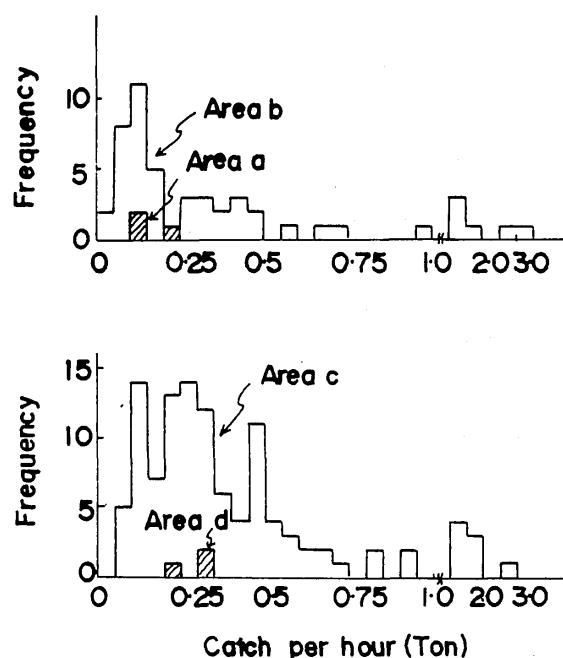

Fig. 2 Catch per hour frequency distribution by area.

Table V. Trawl catch by depth. Data for cruise 1 to cruise 8 are combined

Items	Depth (metres)			
	30–40	40–50	50–60	60–80
No. of hauls	108	44	10	3
Mean of catch/hr (kg)	509.3	285.9	222.3	168.4
C.V. (%)	108	73	55	20
Geometric mean catch/hr (kg)	354.0	208.9	191.5	165.6
70% C.L.				
Upper L.	381.1	238.2	232.8	196.8
Lower L.	328.8	183.2	157.4	139.3

4. DISCUSSION AND CONCLUSION

The data collected so far has indicated that the waters in north Andaman Sea are a comparatively rich and exploitable fishing ground, with species composition very different from those of the trawl catch in the South China Sea. The species composition however varied according to depth. In shallow waters, croaker, catfish, golden snappers, shad, jacks and scads were the dominant species. White pomfret also occurred in shallow waters. In deeper waters, red snappers, lizardfish and threadfin snappers were relatively more abundant. In this respect, areas a and d and areas b and c therefore gave a different species composition, the former two areas being deeper than the latter. Usually good catches in areas b and c were associated with good catches of croaker and golden snapper which, at times, consisted more than 50% of the catch per haul. However, the catch of golden snapper, white pomfret, and mackerel were rather sporadic. This may be due partly to the behaviour and distribution pattern of the fish, and partly to seasonal of tidal

conditions.

Although the species composition of trawl catch in this fishing ground was remarkably different from those of most areas in the South China Sea, a high similarity in species composition was observed between the catch of the present surveys and that obtained from waters off Sarawak in November 1972. During the latter trip, CHANGI operated only in shallow waters (26–48 m), and about 50% of total catch was occupied by croaker, catfish, shad, golden snapper, and jacks and scad, although red snappers also showed high percentage of 12.9% (in preparation). It appears therefore that the depth and bottom topography are factors which may determine the differences or similarities in species compositions of the two areas.

The trawl surveys were restricted to the months of December and January, and therefore, it is difficult to determine if seasonal fluctuation affects the species composition. However, it may be noted that white pomfret was caught in substantial amounts in the four cruises in December 1972 but was negligible in January 1973.

The differences in catch per hour and species composition have been shown to be related to depth. It seems that the good fishing grounds are distributed in the shallow waters of not more than 40 metres deep. However even within the shallow waters, the catch per hour varied considerably, indicating a rather patchy distribution of good fishing localities. The deeper waters, especially those at a depth of 6–80 metres yielded comparatively poor catch. Nevertheless, the mean value for catch per hour (168 kg) in such waters were at the same level as those in the good fishing grounds in the South China Sea.

The formation of good fishing grounds in the shallow

water may not be attributed to the depth itself. A rich supply of nutrient salts, less saline water masses, and muddy bottoms caused by the discharge of Irrawaddi and Sittang Rivers may be supporting the high productivity thereby creating suitable environments for coastal demersal fishes in this region.

The fishing ground in north Andaman Sea is promising and has economic potential. However, more surveys need to be carried out to study the fluctuation of catch and the distribution pattern of the fishing ground.

5. ACKNOWLEDGEMENTS

The authors wish to express their sincere gratitude to the Director of Primary Production Department, Singapore, the Project MANAGER OF FAO/UNDP Fisheries Training Centre and the Chief of the Training Department for providing the trawl fishing data collected by their training vessels, JURONG and PAKNAM, during their surveys in north Andaman Sea, and to Mr. T. Hirota, captain, Mr. C. Miyata, masterfisherman and all crew members of the research vessel CHANGI of the Marine Fisheries Research Department, SEAFDEC.

Mr. Chen Foo Yan, chief and Dr. S. Mito, deputy chief of Research Department have kindly read the manuscript and made many valuable criticisms and advice. For these, the authors express their hearty gratitude.

References

- Anonymous. 1972. SEAFDEC Research Department Annual Report 1971, Fisheries Resources Section, p. 11–23.
- Senta, T., S. M. Tan and P. Y. Lim. 1973. Results of the experimental trawlfisheries in the South China Sea by R/V Changi, in the years 1970 to 1972. Paper submitted to SEAFDEC Seminar, May 1973, Bangkok.

SEAFDEC/SCS.73: S-15

Demersal Fish Resources in Untrawlable Waters, Viewed through Vertical-Line Fishing

by

Tetsushi Senta, Chuichi Miyata and Sen Min Tan

Marine Fisheries Research Department
Southeast Asian Fisheries Development Center

Abstract

Rocky reefs (80–120 m. in depth) along shoulders of steep continental slope in the South China Sea and the Andaman Sea often provide potentially good fishing grounds. Demersal fish resources in these reefs, having quite different species composition from those in trawl fishing grounds, have been scarcely exploited so far.

The results of the recent surveys by Japanese research

vessels and by R/V CHANGI revealed that vertical line fishing is promising in such untrawlable fishing grounds. The daily catch often exceeded one ton and was composed mainly of white snapper, gold-lined sea bream, grouper, pigface, trevally and jobfish.

The catch and species composition in different areas did not vary much provided that the above mentioned bottom feature and oceanic environment were present. Daily catch may fluctuate considerably the above men-

tioned bottom features but tends to be equally poor during the period around the 4th day of a lunar month.

While the relatively inexpensive fishing gear and equipment for vertical line fishing are important, the skill of skipper and crew in searching for fish schools and in the manoeuvring of vessel and gears will affect the catch.

1. INTRODUCTION

Except for its south western part, the South China Sea has only a narrow band of continental shelf. The 500 m depth contour approaches so near to the east coast of Vietnam, the eastern half of north coast of Borneo and the Philippines that the continental slopes are very steep in these areas. Rocky reefs are usually found along the shoulders (80–120 m. in depth) of the steep continental slope, and schools of esteemed fishes are often located in these untrawable areas. Such potential fishing grounds, which may also occur in some bank formations of the South China Sea and in the Andaman Sea of the region, have not been fully developed and exploited.

For the past decade, some Japanese fishing boats have been operating vertical line fishing ("taté-nawa") in the South China Sea for the purpose of exploiting demersal fish resources especially white snapper (*Pristipomoides* spp.), inhabiting these rocky reefs. In 1971/72 fiscal year, the Japanese Marine Fisheries Resources Exploitation Center (MFREC) chartered two boats for experimental "taté-nawa" operations in the Andaman Sea. For the sake of convenience the two Japanese vessels are designated as boat I (276.3 GT) and boat II (100.0 GT) in this paper. Although a Japanese fiscal year is from April through March of the following year, boat I operated from November 1971 to March 1972 while boat II operated from January to May 1972. The results obtained have been encouraging (Anon., 1972 a, b). For 1972/73 fiscal year MFREC sent another vessel (boat III) to the Andaman Sea.

With the aim of exploring and developing every possible fisheries resource in the region the Marine Fisheries Research Department of the Southeast Asian Fisheries Development Center (SEAFDEC) has been preparing for "taté-nawa". In February/March and April 1973 the 387 GT research vessel CHANGI conducted two preliminary vertical line operations, one to the Andaman Sea and another to the South China Sea respectively.

As there is an urgent need for intensive and concerted research on the abovementioned fisheries resources the present paper, summarizes the results of experimental vertical line fishing obtained mainly by boats I and II.

2. DATA USED AND TREATMENT OF DATA

2.1 Main data

For the most part of this paper, the operation and catch records of boats I and II are utilized. The catches are given for each of the major species in terms of number of boxes (each containing 11 kg. of fish on average) plus individual number of surplus fish, and in the case of boat II in terms of total individual number. As is explained later in 3.2, daily operation was made at several locations.

Boat II gives the catch record for each spot, while boat I gives the daily total catch. Before freezing, some of the fish species were dressed (viz. the head and viscera were cut off) and the catch record of these species represents headless fish. Average yield rate of dressed fish for each of these species is also shown in the report (Lit. Cit., 1972 a).

In this study the following treatment of the catch records of the two boats were made before any further calculation:

The catch of boat II at each spot was totalled to a daily catch.

The daily catch in kilograms was obtained by a) multiplying the number of boxes by 11 kg. and b) multiplying the individual number of surplus fish by average body weight of each species. The latter calculation was based on the total individual number caught, total number of boxes and total individual number of surplus fish obtained by boat II for the whole experimental period.

From the average yield rate of dressed fish the recorded catch of each of the dressed fish was converted into the catch of round fish. On analysis the logarithm-transformations were made on the catch record. Thus, in this paper, the means are geometric means.

2.2 Supplementary data

Since the data obtained by CHANGI during the 9-day operation in the Andaman Sea and 4-day operation in the South China Sea are limited they can only be used as supplementary data. Besides, with the exception of the second author, none of the crew had the experience in operating "taté-nawa." The exercise therefore provided the crew the opportunity to gain some experience in vertical line fishing rather than being only to collect data for the assessment of fish resources.

The boat III from MFREC conducted her first and second trips in the period from August to September 1972. Since no other record is available for these months which are in the south-west monsoon season, her catch record for the period is utilized as additional data.

3. BRIEF ACCOUNT OF FISHING GEAR AND FISHING METHOD

3.1 Fishing gear

The fishing gear used by CHANGI, not very different from those used by boats I and II, is composed of the following:

- a) a lead line (nylon, 180 lbs., 300 m. long)
- b) a main line (nylon, 130 lbs., 3 m. long) connected to a free end of lead line by means of swivel
- c) four to five branch lines (nylon, 80 lbs., 50 cm. long) attached to a main line with swivels at intervals of 1.5 m.
- d) a hook of 6 cm. long at an end of each branch line
- e) a sinker, 1.0 to 2.0 kg, at a lower end of a main line
- f) a reel (30 cm. in diameter) with a guide roller, stopper, clutch and winding handle for facilitating the paying-out and pulling-in of lead line.

Many varieties or modifications may be possible to improve the catching efficiency. A Japanese commercial

boat, about 80 tons, operating on Vangurd Reef in the South China Sea as witnessed by CHANGI used sinkers which also served as containers for attractant bait.

3.2 Method of operation

Fish schools are located by means of the fish-finder. As schools of desirable fishes are distributed on rocky reefs along the shoulder of the steep, it is wise to sail in a zigzag fashion along the upper margin of the steep. As soon as a school of demersal fishes is found, a marker-buoy is set and the vessel is allowed either to drift or anchor while angling near the buoy.

Slices of fresh squid, small-sized fish either fresh or salted, etc. are used as bait giving almost no difference in result. Feeding activity of fish school may last for only 30 minutes or even a few hours. When the fish school stops feeding, the vessel shifts its position a little or begins a search for the next school. Daily operations are, therefore, made at several spots.

4. FISHING GROUNDS:

WHERE TO SEEK FOR FISH SCHOOLS

4.1 Topography of sea bottom

Fig. 1 illustrates the areas where boats I, II and CHANGI conducted operations after fish schools were located. The fishing grounds were found only in narrow belts along the upper margins of continental slope or around islands and banks. The depth of the sea seems to be one of the important factors for forming good fishing grounds. While rocky reefs of depths of 80 to 120 m. found along the shoulders of the steep always provide good fishing grounds, desirable fish schools are seldom found or reefs of similar topography in shallow waters such as 30 to 40 m. deep.

4.2 Oceanographic conditions

In Fig. 1, the operated areas are grouped into 5 geographical areas, A–E, for convenience of explanation. Table I compared the mean catch per day by areas.

From the table, it is obvious that no good catch is expected in area E. The fact that the number of days operated in area E is few also means that promising fish schools were rarely recorded by the fish-finder in this area.

The other four areas, A–D, were considered to be of the same value as fishing grounds. Their confidence limits of mean catch per day overlapped even at such a low level as 68%. Areas C and D were visited less often, since the catches were not much different from those in areas A and B while the distance from the base port in Penang is greater. Boat II spent 3 days in searching for fishing grounds in the northern Andaman Sea beyond 14° latitude, but without much success.

Table II shows the change in surface and bottom salinity from the Straits of Malacca to the Andaman Sea observed by CHANGI in February 1973.

Combining the geographic distribution of good fishing grounds and the oceanographic conditions, it seems that good fishing grounds for vertical line are formed only in areas of oceanic waters. Furthermore, prominent upwellings were often found to exist in areas of good fishing ground as determined by sea observation as well as by a fish-finder.

5. SPECIES COMPOSITION OF CATCH AND SIZE OF FISH

5.1 Main objectives of vertical line fishing

While snapper (*Pristipomoides*) is by far the most important species among the catch, usually occupying about 60% or more of total catch. Gold-lined sea bream (*Gnathodentex mossambicus*) comes next, constituting about 20% of the total catch. Groupers (*Epinephelis* and *Cephalopholis*), pigface (*Lethrinus*), trevally (*Caranx chrysophrys*) and jobfish (*Aphareus rutilans*) are also of some significance in the catch.

Table I. Geometric means of catch per day by area calculated for combined data of boats I and II for the whole period, Nov. 1971 to Apr. 1972

Area	A	B	C	D	E
Days operated	97	21	6	6	5
Mean catch per day (kg)	552	585	331	1044	24
Antilog. of standard deviation	2.32	2.61	2.44	1.79	3.22
68% confidence limits					
Upper limit (kg)	1290	1530	809	1890	79
Lower limit (kg)	238	224	136	586	8

Table II. Salinity of the sea along the west coast of Malay Peninsula by latitude, February 1973

Latitude	5°00'N	7°00'N	9°30'N	12°00'N	15°05'N
Depth of the sea (m)	82	78	160	2000	43
Salinity ‰/00					
Surface	31.58	32.18	32.76	32.04	30.59
Bottom	33.94	34.56	34.98	34.96	34.10

Pristipomoides typus and *P. filamentosus reseus* are two species of white snapper, of which the former outweighed the latter by about 1.5 times. There are 2 types of *P. typus* which show a rather remarkable difference in some features such as body colour and patterns on the head (in one type several yellow stripes run horizontally on the cheek some of which extend onto the body, while the other type is more reddish in colour without yellow stripes), suborbital depth, etc., although both have the same number of lateral line scales, 49–50. Important among several species of groupers caught are *Epinephelus chlorostigma*, *E. amblycephalus*, *E. areolatus* and *E. morrhua*. Pigface is composed of two species, *Lethrinus miniatus* and *L. choerorhynchus*.

5.2 Species composition by area

Table III shows the species composition of the catch by boats I and II for the whole period of operations. Species compositions of catch are not much different by areas, except for area E. According to information obtained from the Japanese commercial boat mentioned in 3.1, the catches in the South China Sea do not show much difference in species composition.

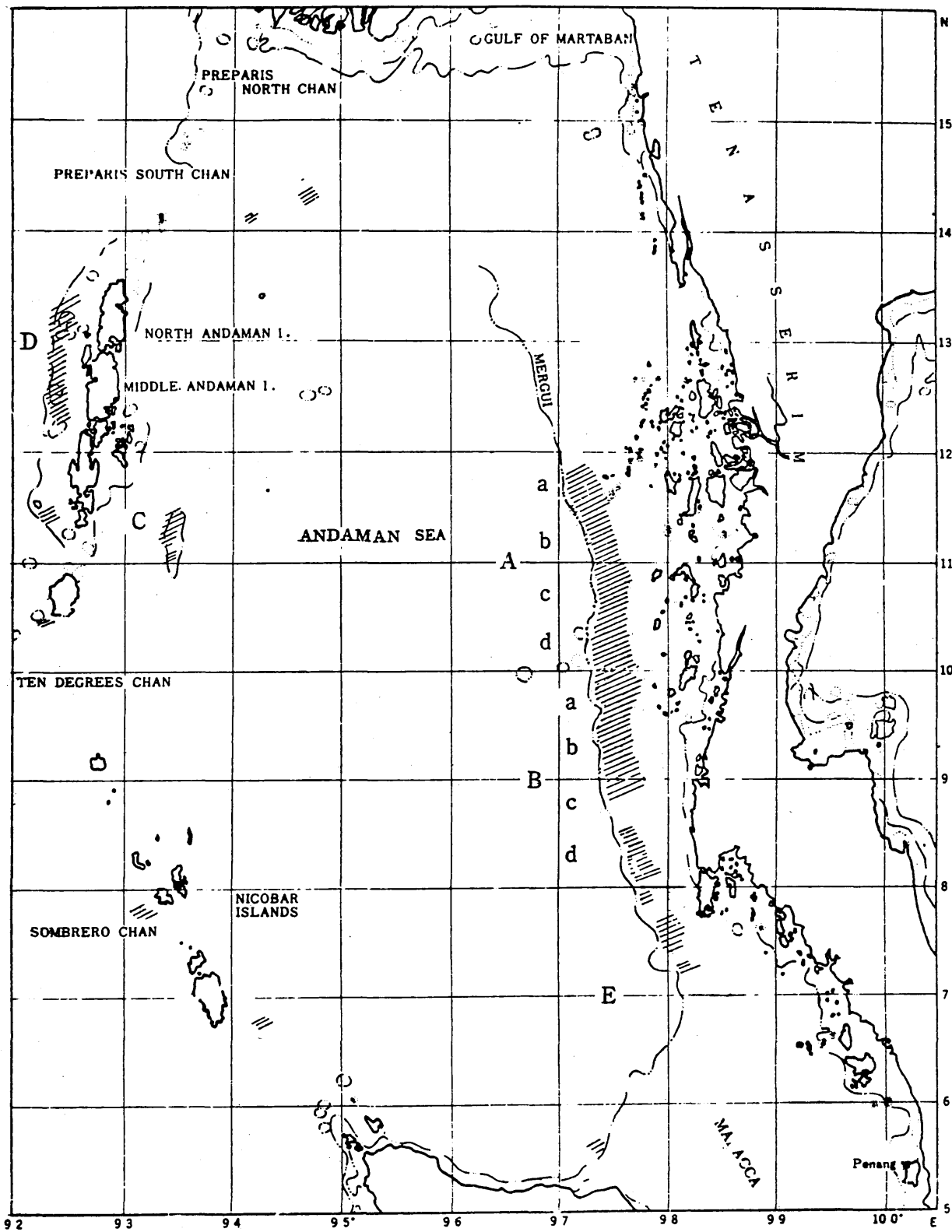

Fig. 1 A chart to show vertical line fishing ground (shaded areas) in the Andaman Sea operated by Japanese boats I and II and CHANGI. A-E shows the division of operated fishing grounds into 5 areas, a-d showing subareas of areas A and B which correspond those in Figs. 2 and 3.

Table III. Species composition of the catch by area for combined data of boat I and II for the whole period, November 1971 to April 1972

Area	A	B	C	D	E
Total catch (ton)	74.5	21.2	2.6	7.0	0.2
	%	%	%	%	%
White snapper	58.0	70.9	50.8	72.7	65.7
Gold-lined sea bream	21.6	10.2	24.4	16.4	0.0
Grouper	8.6	4.4	6.9	1.0	11.9
Pigface	2.8	6.5	10.2	1.3	0.0
Trevally	5.4	5.5	1.3	0.9	0.0
Jobfish	0.8	0.6	0.0	5.2	0.0
Others	2.8	1.9	6.4	2.5	22.4

5.3 Size of fish in the catch

Figs. 2 and 3 show the length frequency distribution of two species of white snapper caught by boat II. The fork length which is about 10% longer than standard length was measured.

Fig. 2 indicates that most of *Pristipomoides typus* in the catch ranged from 50 to 62 cm. in fork length. According to measurements of both body length and body weight of the fish made on board CHANGI, the fish of the above mentioned size range weighed from 2 to 4.5 kg. From Fig. 3, it is seen that *P. filamentosus roseus* on average was slightly smaller than *P. typus*. In the catch and measurement record of boat II, the 2 types of *P. typus* are not separated (in boat I, the 2 species were collectively recorded as white snapper). Measurements made on board CHANGI (Fig. 4) showed that the reddish type of *P. typus* was smaller than the yellow type.

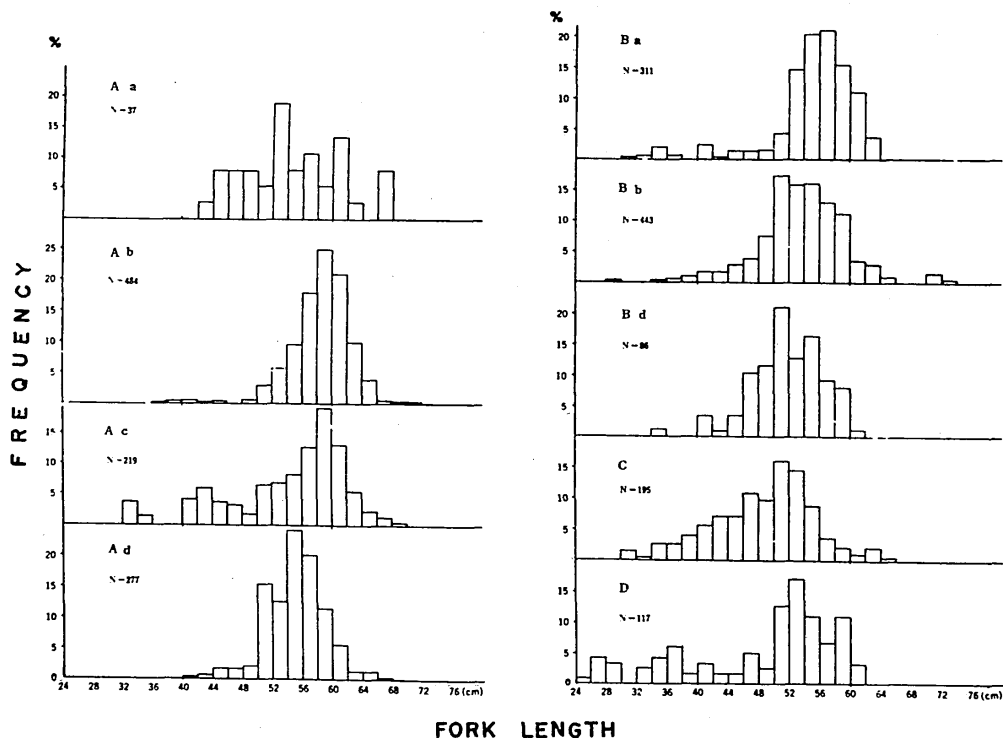

Fig. 2 Body length frequency histograms of white snapper, *Pristipomoides typus* caught by boat II, from different areas. Aa-D shows area/sub-areas, and N is number of fish measured. (after Anon. 1972a)

For the other species, the frequent size ranges in the catch were as below:

Gold-lined sea bream, 30–46 cm. in fork length, 0.7–2.7 kg in body weight

Grouper

E. chlorosigma, 40–50 cm. in standard length, 1.5–3.12 kg

E. amblycephalus, 40–60 cm. in standard length, 1.7–5.0 kg

E. areolatus, 25–33 cm. in standard length, 0.5–0.8 kg

Pigface

L. Miniatus, 60–65 cm. in standard length, 4.0–5.5 kg

L. choerorhynchus, 45–54 cm. in standard length 2.0–3.5 kg

Trevally, 45–55 cm. in fork length, 1.6–3.0 kg

Jobfish, 50–75 cm. in fork length, 2–5 kg.

6. CATCH BY SEASON

6.1 Catch per day by season

Catch data in areas A and B are combined for further discussion, since the average catch per day and the species composition are not very different between the 2 areas (Table I and III). Data from areas C and D are omitted because of geographical isolation from areas A and B.

Table IV compares the means of catch per day by periods of operation. The data for each boat is treated separately, since the difference in the skill of the crew in vertical line fishing between the boats would have affected the results. The data for August–September (south-west monsoon season) is supplemented by the catch record of boat III. Although the mean catch per day was higher in

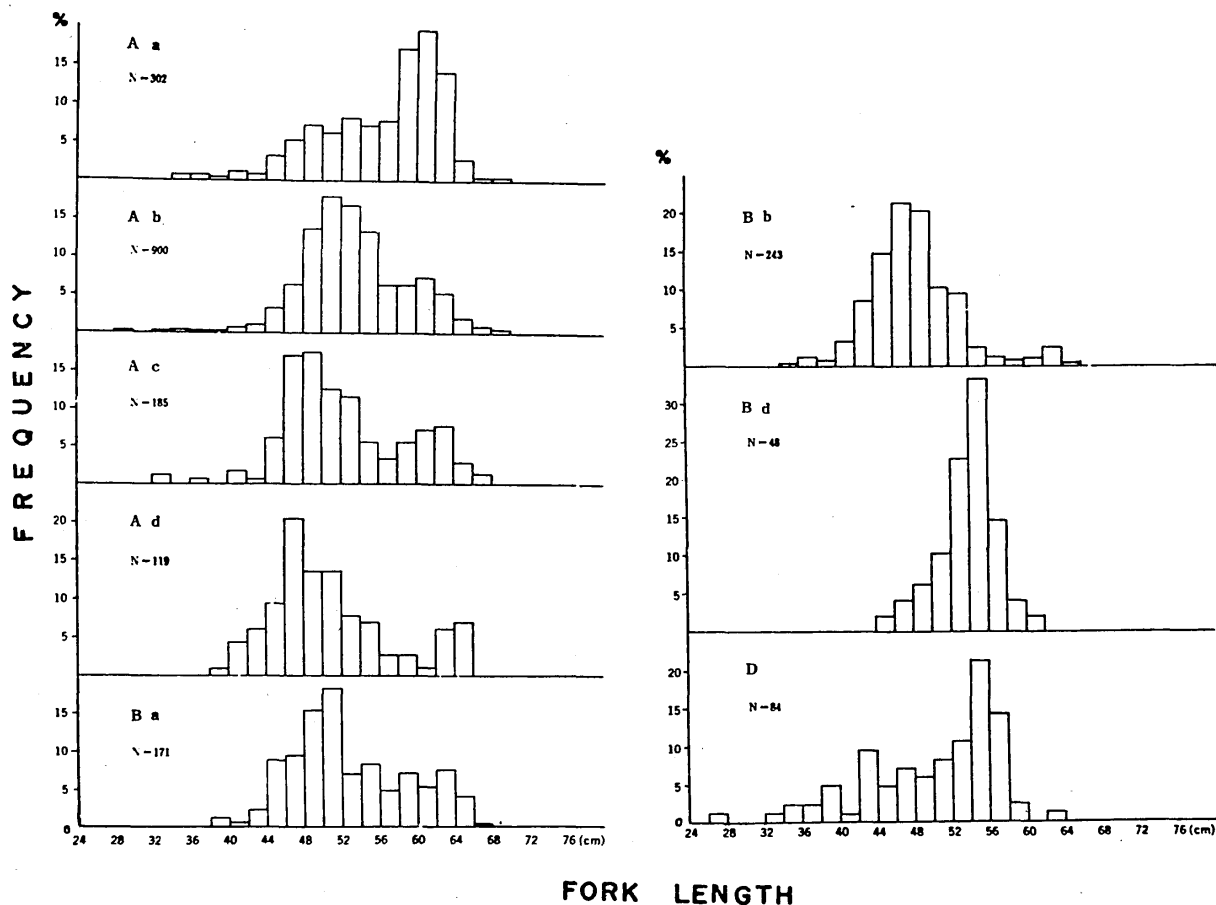

Fig. 3 Body length frequency histograms of white snapper, *Pristipomoides filamentosus roseus* caught by boat II from different areas. Aa-D shows area/sub-areas, and N is number of fish measured. (after Anon. 1972a)

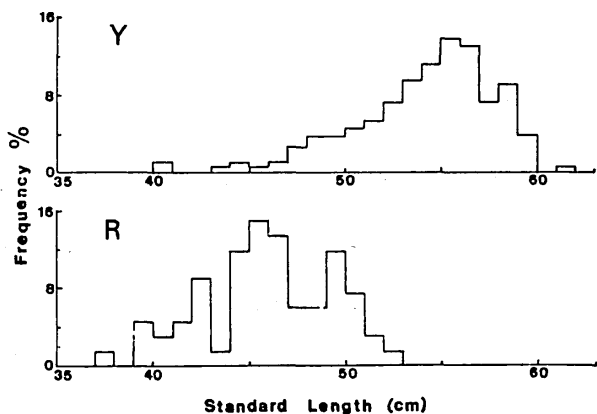

Fig. 4 Body length frequency histogram of two types of *Pristipomoides typus* caught in areas A and B by changi.

Y: yellow type with yellow stripes on cheek.
R: reddish type without yellow stripes on cheeks.

January–March period as shown in the table, the 68% confidence limits of the average for each period overlapped. It may be concluded that the fluctuation in fishing conditions for vertical line by season is small compared with the daily fluctuation.

6.2 Species composition by season

Table V shows the species composition by periods for the same data as in 6.1. A certain degree of difference in the species composition is seen, although white snapper and gold-lined sea bream always occupied the highest percentages. In November–December period low percentage of white snapper combined with high percentage of gold-lined sea bream and the absence of pigface and jobfish is characteristic. In April, grouper occupied a considerably higher percentage compared with other periods. August–September period showed a high percentage of white snapper and a rather low percentage of gold-lined sea bream. The species composition in January–March period was found to be in between those of the other periods.

7. EFFECT OF TIDAL CONDITION ON CATCH

7.1 Average catch by tides

It is often observed in angling that the fishing condition (i.e. the feeding activity of the fish) is better in spring tides than in neap tides. In order to examine whether this occurs also in the vertical line fishing, the catch records of boats I and II in areas A and B are grouped into four stages according to the tidal condition of the day of operation. The four stages employed here

are:

- a. first spring tide (S. 1): 27th-3rd day of Lunar month
- b. first neap tide (N. 1): 4th-11th day of lunar month
- c. second spring tide (S. 2): 12th-18th day of lunar month
- d. second neap tide (N. 2): 19th-26th day of lunar month.

The geometric means of catch per day for boats I and II by the tidal stages (Table VI) indicate no obvious difference at 68% confidence limits.

7.2 Daily catch against the day in lunar calendar

For further examination of the effect of tidal condition on the fishing condition, the daily catch of boats I and II in areas A and B obtained in those trips when operation exceeded 14 days are plotted against the day of a month in the lunar calendar (Fig. 5).

Although the daily catch fluctuated within a total stage, there is a remarkable tendency for the fishing condition to be usually poor for several days around the 6th day of a lunar month. During spring tides and a few days after the second spring tide the catch fluctuated remarkable from day to day.

Table IV. Geometric mean of catch per day by periods and by boats. The data for areas A and B combined

	Nov.-Dec. 1971	Jan.-Mar. 1972	April 1972	Aug.-Sept. 1972
Boat I				
Days operated	26	45	0	0
Mean catch/day (kg)	587	849		
Antilog. of standard deviation	2.26	2.36		
68% confidence limits				
Upper limit (kg)	1325	2000		
Lower limit (kg)	260	369		
Boat II				
Days operated	0	34	19	0
Mean catch/day (kg)		410	352	
Antilog. of standard deviation		2.29	2.04	
68% confidence limits				
Upper limit (kg)		938	719	
Lower limit (kg)		179	179	
Boat III				
Days operated	0	0	0	0
Mean catch/day (kg)				712
Antilog. of standard deviation				1.78
68% confidence limits				
Upper limit (kg)				1270
Lower limit (kg)				401

Table V. Species composition by periods based upon the data obtained in areas A and B by boats I, II and III

	Nov.-Dec.	Jan.-Mar.	April	Aug.-Sept.
Total catch (ton)	19.7	66.6	8.3	21.5
	%	%	%	%
White snapper	54.9	63.6	53.3	72.4
Gold-lined sea bream	28.4	16.2	19.8	10.5
Grouper	7.4	6.4	15.5	2.0
Pigface	0.0	4.4	6.2	2.1
Trevally	4.0	6.4	0.9	3.5
Jobfish	0.0	0.8	2.0	3.7
Others	5.3	1.8	2.3	5.8

Table VI. Geometric mean of catch per day by tides as calculated for the data of boats I and II in areas A and B

Tidal stage	S.1	N.1	S.2	N.2
Boat I				
Days operated	19	22	22	8
Mean catch/day (kg)	606	657	869	942
Antilog. of standard deviation	2.46	1.72	2.47	3.00
68% confidence limits				
Upper limit (kg)	1950	1130	2140	2826
Lower limit (kg)	247	382	351	314
Boat II				
Days operated	14	10	13	16
Mean catch/day (kg)	526	238	505	326
Antilog. of standard deviation	1.74	2.10	2.05	2.43
68% confidence limits				
Upper limit (kg)	918	500	1130	795
Lower limit (kg)	302	114	251	134

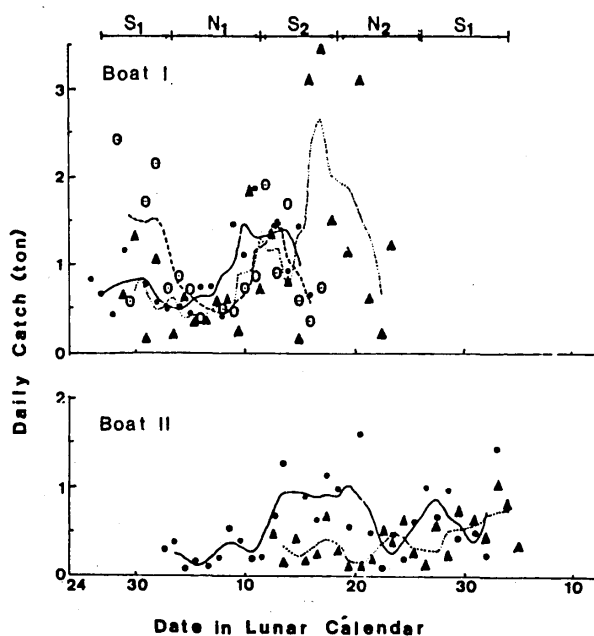

Fig. 5 Daily catches of boat I (top) and boat II (bottom) plotted against the date in lunar calendar. Marks show daily catches, and lines represent smoothed curve by way of arithmetic moving means for each 3 consecutive days.

- I. Solid circles and solid line: trip Dec. 1971 – Jan. 1972
 Triangles and dotted line: Jan. – Feb. 1972.
 Double circles and broken line: Feb. – Mar. 1972.
 II. Solid circles and solid line: trip in Jan. – Feb. 1972.
 Triangles and dotted line: trip in Mar. – Apr. 1972.
 S_1 : first spring tide S_2 : second spring tide
 N_1 : first neap tide N_2 : second neap tide

8. CONCLUSION AND SUGGESTIONS

8.1 Prospects and merit of vertical line fishing

From the discussions in the previous chapters, it is clear that promising demersal fish resources exist and are not fully developed and exploited. Although the possible daily total catch may be less than that of trawl fishing, the catches of vertical line fishing are almost exclusively composed of fishes of high marketability. The fishing gear and equipment needed for this fishery are much less expensive than those for trawl fishery, and can be operated by boats of much smaller size.

The fish species caught by the vertical line fishing are also different from those for trawl fishing. Those species such as *P. filamentosus roseus*, gold-lined sea bream, *Epinephelus chlorostigma*, *E. amblycephalus*, *Lethrinus choerorhynchus*, jobfish and trevally which are main components of the vertical line catch seldom occur in the trawl catch. In other words, these two methods of fishing exploit two different groups of demersal fish resources.

One of the advantage of the vertical line fishing as compared with the bottom long-line is in its mobility. Ease in manipulating the fishing gear facilitates the manoeuvring of the boat in its operation.

The stock size of such demersal fish resources in the South China Sea and the Andaman Sea may be smaller than fish resources for trawl fishing, because the distribution of fish resources for the vertical line fishing is restricted in narrow bands along the upper margin of the continental steep. This makes the locations of fishing grounds much easier.

Apart from the boat itself, the only costly equipment is a fish-finder, which in relative terms is not expensive. In the early stage of developing vertical line fishing one fish-finder can serve a fleet of about 3 boats. On locating fish schools the boat equipped with the fish-finder sets a market buoy bearing the same number as one of the boats which can then commence vertical line operation.

8.2 Importance of skill

Improvement of skill through experience are essential for successful operation of vertical line fishing. Not only the skipper must be familiar with the location of potential fish reefs and the quick manoeuvre of his boat during operation the crew must also be skillful in the handling of fishing gear. Knowledge of the design and improvement of fishing gear is an added advantage especially in the use of some attractant device as mentioned in 3.1.

8.3 Future studies

As the accumulated data on vertical line fishery resources are limited, urgent and intensive studies are needed. With the presently available data fluctuation and difference in catch and species composition by areas and seasons can only be discussed superficially in this paper. Detailed studies on these as well as on the effect of tidal stages are needed. Tidal phases, viz. flow, stagnant and ebb, may also affect the feeding activity of fishes.

Ecological characteristics of each fish species and physiological aspects, especially seasonal change in gonadal condition, of each species are also important subjects to be studied.

9. ACKNOWLEDGEMENT

Thanks are due to Mr. Chen Foo Yan, the Chief of the Marine Fisheries Research Department, Southeast Asian Fisheries Development Center, for his kind reading of the manuscript and valuable advice.

References

- Anonymous. 1972a. Report of investigation on new fishing grounds for bottom long-lining with the purpose of industrialization, 1971 fiscal year. Marine Fisheries Resources Exploitation Center, Report 1971, no. 9, pp. 1–59, 3 pls. (in Japanese).
 Anonymous. 1972b. Report of investigation on new fishing grounds for bottom long-lining with the purpose of industrialization, 1971 fiscal year. Part for Data. Marine Fisheries Resources Exploitation Center, Report 1971, no. 9–1, pp. 154 (in Japanese)

Biological Study of Red Snapper,
Lutjanus Sanguineus

by

T. Senta, P. Kungvakij* and Sen-Min Tan

Marine Fisheries Research Department
Southeast Asian Fisheries Development Center
Changi Point, Singapore

Abstract

Among the red snappers caught by trawling in the South China Sea, *L. sanguineus* is the most important species, comprising more than 10% of the total catch. Although *L. sanguineus* is widely distributed in the South China Sea, its pattern of distribution seems to be rather patchy. However, they were most abundant at 35–80 m. water depth and inhabit muddy-sand areas especially where "Neptune's cup" are abundant.

Size frequency histograms indicate four to six size groups, with peaks of almost the same height. The growth rate of fish of 23 cm. was taken to be approximately 2 cm. per month.

As no significant difference in length-weight relationship between male and female was observed, the following formula can be applied for both sexes.

$$W = 7.64 \times 10^{-5} L^{2.823}$$

where, W = body weight (g).

L = body length (mm).

The number of ovarian eggs ranged from 69 to 260.10⁴ and the regression between the number of eggs in thousand (N) and fish weight in gram (W) was $N = 0.4459W + 83.2$.

High values of gonadal index from March to November with a peak in April–June suggests a prolonged spawning season.

1. INTRODUCTION

In the South China Sea, red snappers are the most important fishes in the trawl catch, the dominant species being *Lutjanus sanguineus* (Cuvier et Valenciennes).

Since few publications on the fisheries biology of this species are available, in spite of its relative importance in the fisheries of Southeast Asia, the Marine Fisheries Research Department of the Southeast Asian Fisheries Development Center (SEAFDEC) carried out some biological studies on the fish.

* Present address: Marine Fisheries Station, Phuket, Thailand

2. MATERIALS AND METHODS

This study is based mainly on the data and materials obtained from trawl operations carried out by the 387-ton research vessel CHANGI from February 1971 to September 1971. However, data collected in 1970 and from

October 1971 to October 1972 (including two trips of bottom longline fishing survey) are also incorporated.

Specimens collected were measured and weighed fresh on board the vessel, while ovaries and stomachs were weighed and preserved in 10% formalin for laboratory analyses. Measurements of total length were taken for all *L. sanguineus* caught by CHANGI. Additional measurements and collection of ovaries and stomachs were also made on the commercial catch from the South China Sea landed in Jurong Fish Market, Singapore in March, May and August 1971.

3. RESULTS

3.1 Fisheries Status and distribution

3.1.1 Importance of *L. sanguineus* in trawl fisheries.

Although species composition of trawl catch by CHANGI in the South China Sea varies from area to area, red snappers usually constitute an important part of the catch. In most areas, more than 20% of the total catch were red snappers (Senta, et al. 1973), of which *L. sanguineus* was the most important species, usually occupying about 70% of the total amount of red snappers caught.

3.1.2 Fishing grounds

Figs. 1a and 1b show the values of catch per hour for each half degree block of 30 square miles in each month, from January 1970 to September 1971. Although *L. sanguineus* may be said to be distributed almost all over the South China Sea, its distribution pattern seems to be rather patchy. For example, in August 1970 (Fig. 1b), a catch of more than 50 kg per hour of *L. sanguineus* was obtained from a block while its immediate neighbouring blocks yielded none. Also in May 1970 (Fig. 1a), two areas of good catch were separated by several blocks of poor and no catch; and 2 blocks out of a total of 13 yielded more than 50 kg/hr, while 5 blocks yielded no *L. sanguineus*. In February, June, July and October 1970 the species was caught in almost every block although none yielded more than 50 kg/hr. Due to the lack of regular monthly surveys in each area, it is difficult to assess the seasonal variation of its distribution pattern in the South China Sea.

3.1.3 Distribution by depth

In contrast to geographical distribution, the distribution of *L. sanguineus* by depth was much more consistent. Table I shows the seasonal change in catch per hour by depth. During the period of January–March, the catch

was best in shallower areas, but as the year progressed best catch was obtained in deeper water, and after July, areas shallower than 50 m yielded poor catch. However, the

catch was always poor in areas deeper than 90 m.

The bottom feature was thought to have an influence on the distribution of *L. sanguineus*. From the samples

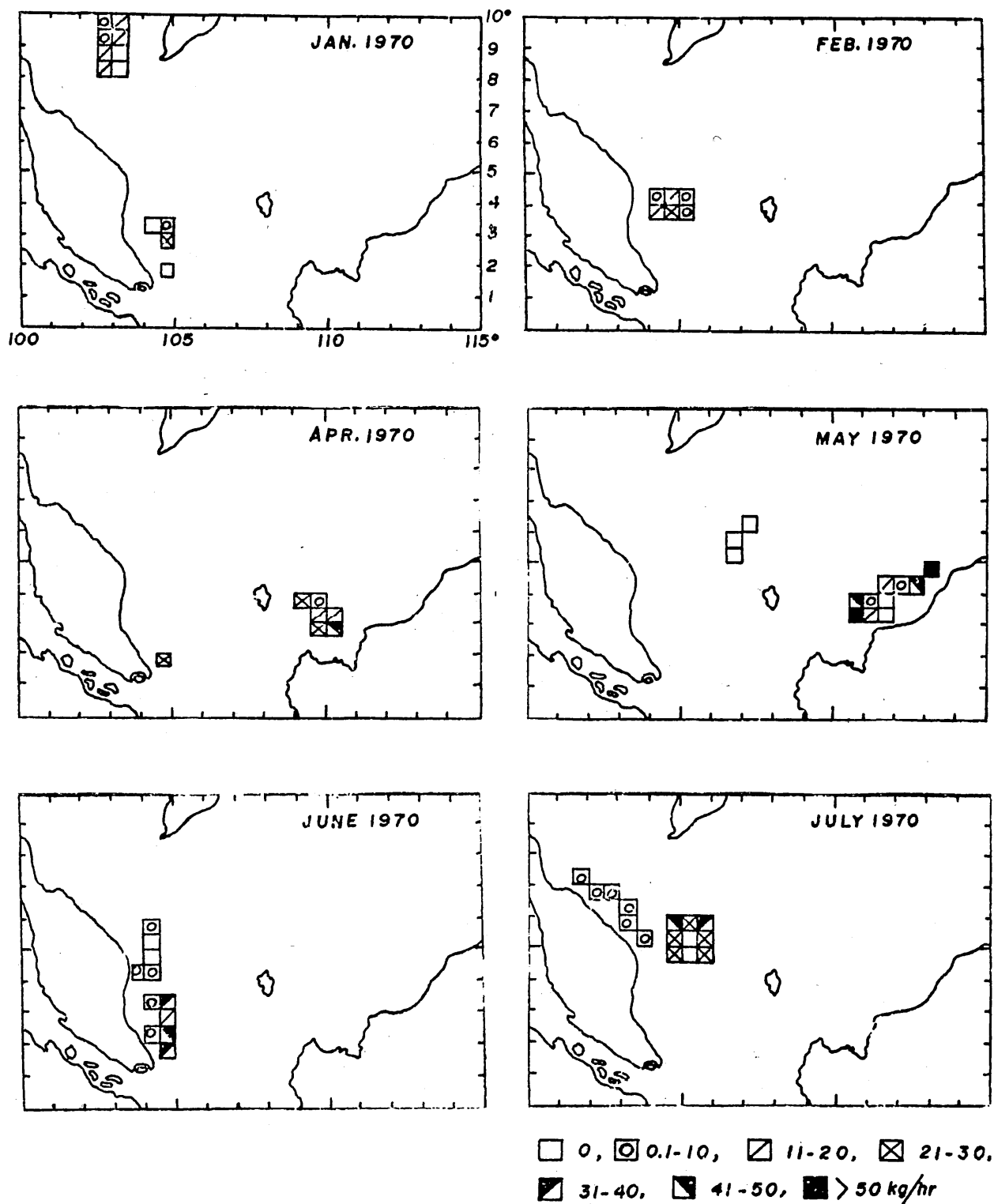

Fig. 1 (a) Monthly variation of catch (kg/hr) of *L. sanguineus*.

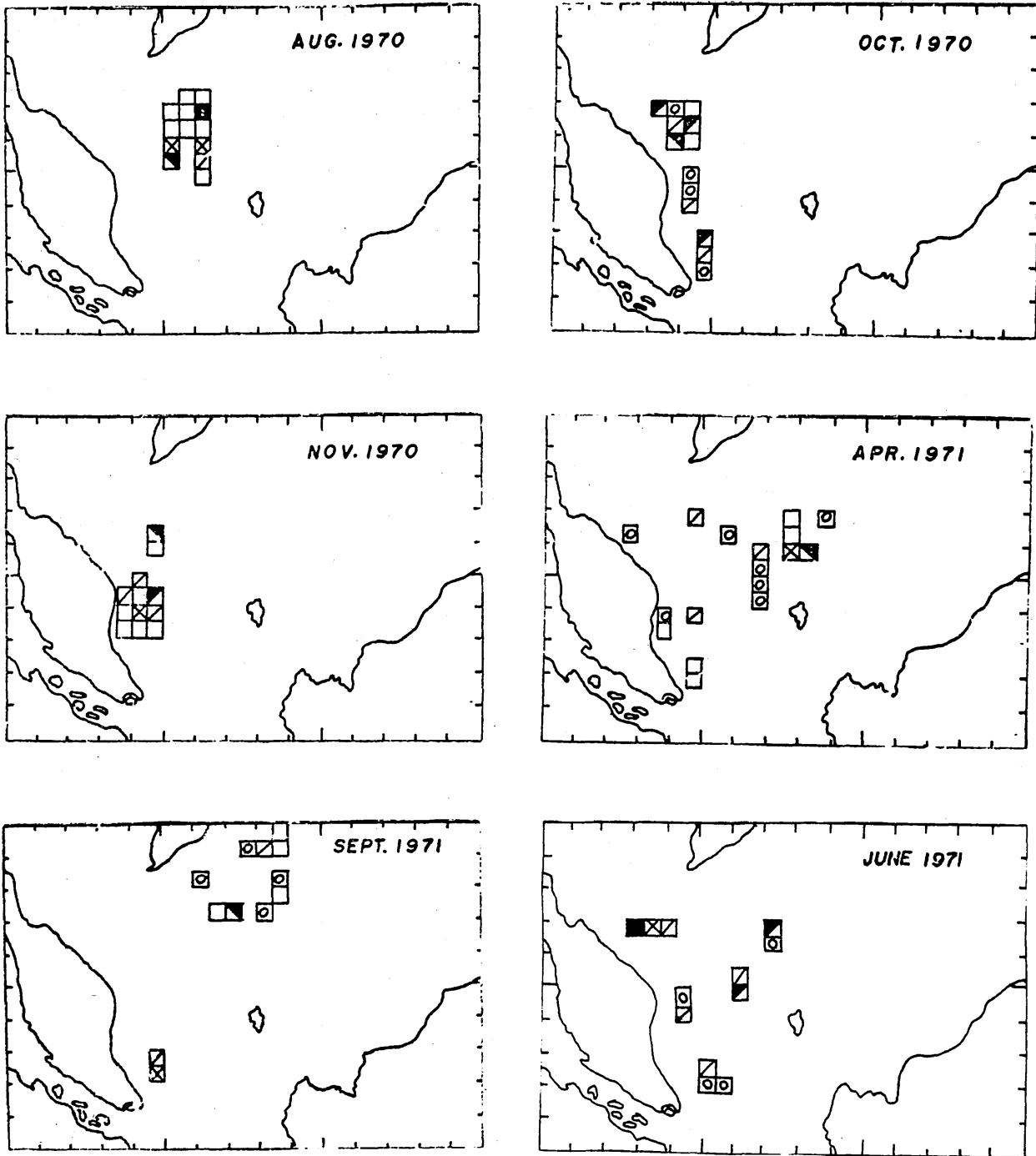

Fig. 1 (b) Monthly variation of catch (kg/hr) of *L. sanguineus*.

Table I. Catch per hour of *L. sanguineus* by depth, by periods, 1970 - 1971

Depth (metres)	Jan.-March		April-June		July-Sept.		Oct.-Dec.	
	H	C/hr/kg	H	C/hr/kg	H	C/hr/kg	H	C/hr/kg
25-40	6	22.4	7	10.23	9	2.1	4	0
41-50	9	18.9	21	31.96	28	13.3	6	2.5
51-60	6	15.3	42	16.99	36	12.6	16	21.7
61-70	19	11.9	60	14.48	17	20.0	29	7.8
71-80	5	15.5	20	31.51	10	14.3	2	15.5
81-90			18	9.94	10	17.8		
91-100					3	1.0		
100					4	4.3		

H = No. of hauls; C = catch

Table II. Relationship between catch per hour of *L. sanguineus* and types of sea beds

Type of bottom	No. of hauls	Catch per hour (kg)
Clay	17	16.36
Mud	10	14.69
Mud + sand	70	20.35
Sand + mud	63	18.22
Sand + shell pieces	13	3.71
Sand	-	-

collected by SK-type mud sampler the sea beds of the fishing grounds were classified into 6 types (Table II). The catch was found to be best on bottoms with a mixture of mud and sand, and the poorest in areas with sand and shell pieces. It was observed that good catches of *L. sanguineus* were often accompanied with a lot of coral (*Melitodes* sp). It is likely that these organisms form a kind of natural fishing reef.

3.2 Size and growth

3.2.1 Body length distribution

Fig. 2 shows the length frequency distribution of *L. sanguineus*. The total length of the species caught by trawl ranged from 16 to 82 cm. Fish of 55–70 cm in total length occupied the largest portion in catch. However, the size range of the catch obtained by bottom longline in June 1972 was 30–70 cm and the largest portion of the catch comprised of fish ranging from 42 to 50 cm. It appears that trawling is not as selective as bottom longline in the exploitation of the population of *L. sanguineus*.

The size frequency histograms of June 1971 and of September 1971 to October 1972 were analysed by the probability paper method developed by Harding (1949), and the mean value of length, standard deviation and percentage of each component group in the total catch were graphically determined. The normal curves thus obtained were superimposed on some of the histograms (Fig. 2). Most of the histograms have four to six peaks of

nearly the same height. In fact the higher peaks are often seen for the larger size range, indicating a relative abundance of large-sized fish.

3.2.2 Growth

From Fig. 2 it is difficult to trace the growth rate of fish in every size group from month to month for a long period, as a continuous collection of sufficient data in a certain area was not attained because of monthly shifts of areas visited by CHANGI. Due to the lack of sequence in the size groups, the growth rate can only be inferred approximately from the present data.

In Fig. 2, there is a prominent peak at 23 cm in June 1971 and a similarly prominent peak at 29 cm in September 1971. Supposing that both were from the same 'age' group, then it could be inferred that fish of 23 cm length in June grew by 6 cm within 3 months. In this case the first group would have grown by 24 cm in a year provided that the growth rate remained the same throughout the year while the third peak (45 cm) could be considered to be one year older than the first. Similarly the second size group in the data from September 1971 may be traced to the third size group in October 1971 giving a growth rate of 2 cm per month. In September 1971, the fourth size group (63.6 cm) could similarly be considered to be one year older than the second size group. Presuming that the above inference is correct each year class may therefore consist of two size groups indicating that there may be at least two major spawning seasons a year.

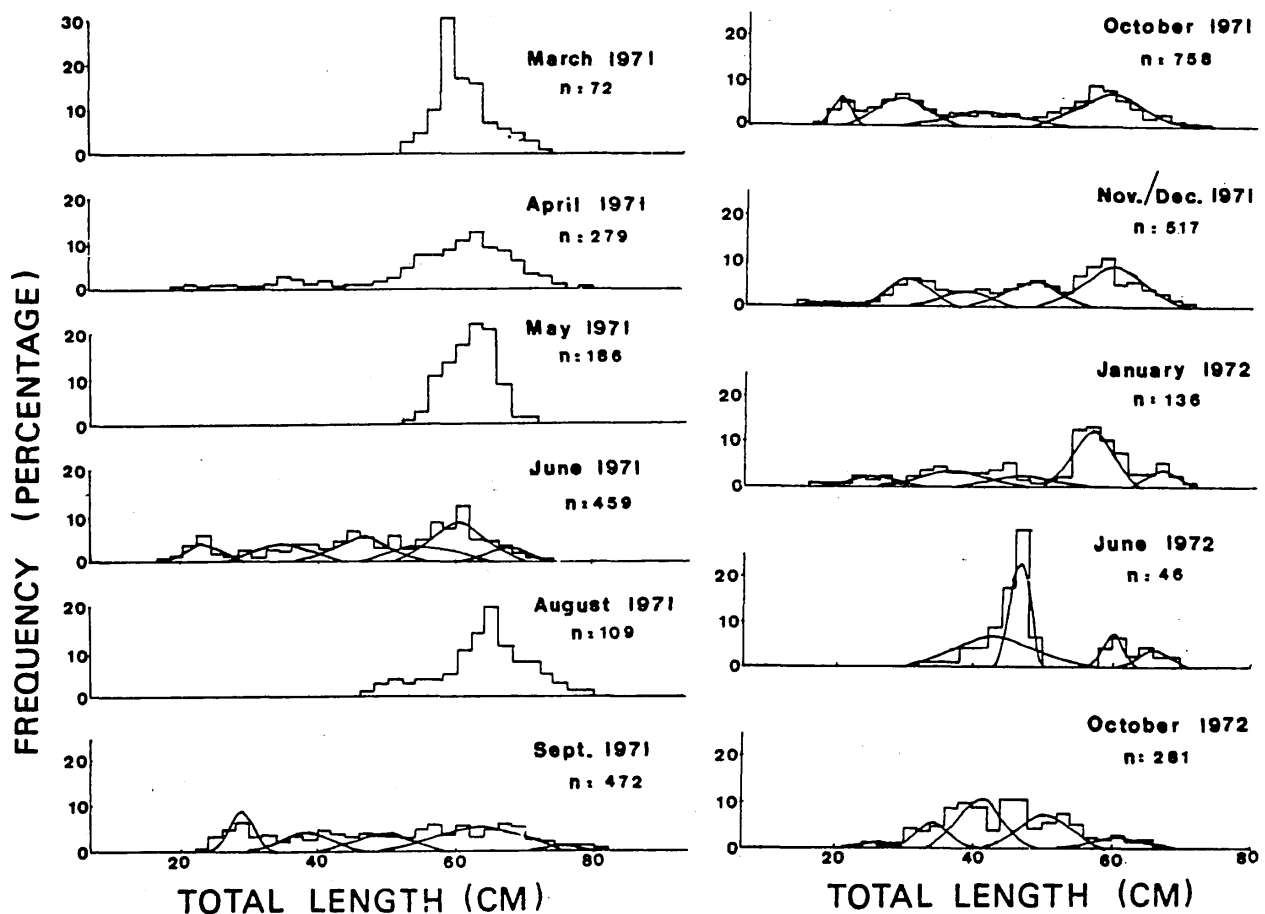

Fig. 2 Size frequency distribution of *L. sanguineus*.

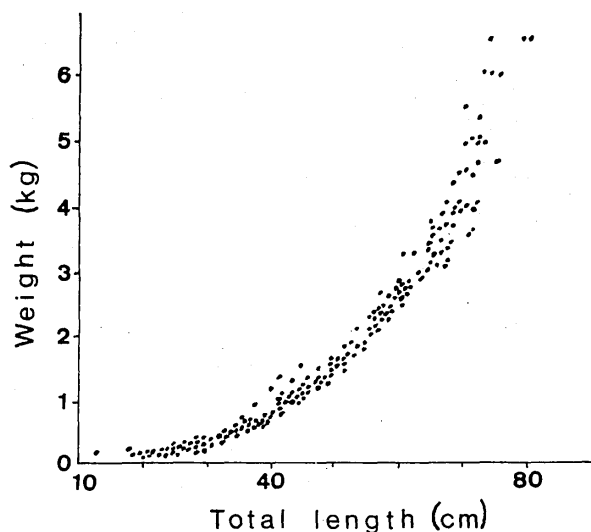

Fig. 3 Length-weight relationship of *L. sanguineus*.

3.2.3 Length-weight relationship

Measurements of total length and body weight for 1213 fish were taken at 2 cm intervals of total length. Average body weight was calculated for the midpoint of each class, and the measurements of body weight were plotted against that of total length (Fig. 3). The regression of weight in gram against total length in mm for each sex were determined by least square method. The resulting formulae were: for male $W = 6.415 \times 10^{-5} L^{2.877}$ or $\log W = 2.877 \log L - 4.562$; for female $W = 1.173 \times 10^{-5} L^{3.000}$ or $\log W = 3.000 \log L - 4.869$. Since F-test showed that there was no significant difference between sexes, the data were combined to form a single formula representing the length-weight relationship for the species: $W = 7.462 \times 10^{-5} L^{2.823}$ or $\log W = 2.823 \log L - 4.419$.

3.3 Reproduction

3.3.1 Sex ratio

Of the 255 fish examined, 126 were males and 129 were females, giving a sex ratio of 0.98 which could be taken as 1:1 by χ^2 test.

3.3.2 Seasonal variation in gonad index

Gonad indices were calculated by the following formula:

$$GI = \frac{GW}{BW} \times 10^3 \text{ where } \begin{array}{l} GI = \text{gonad index} \\ GW = \text{gonad weight (g)} \\ BW = \text{body weight (g)} \end{array}$$

The monthly change in average gonad index is shown in Fig. 4, in which the highest value is seen in April. However, during the peak of the spawning season, some fish would have spawned and consequently would have low GI values, thereby lowering the average value of gonad index for the group. To avoid this, the ovaries were classified into the following four stages according to the GI value and the state of maturity:

- Stage I : GI = 0.1 – 5; immature and spent ovaries
- Stage II : GI = 5.1 – 15; maturing ovary
- Stage III : GI = 15.1 – 30; mature ovary
- Stage IV : GI = 30.1; ripe ovary with bimodal distribution of eggs, the larger mode being at 0.70 – 0.75 mm. Some eggs are transparent.

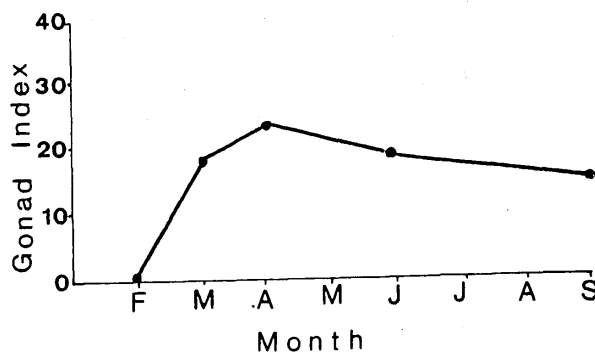

Fig. 4 Monthly change of mean of gonad index.

The percentage of stage IV increased through March to April when it showed its highest value (Fig. 5). The value dropped from 35% in April to 9% in June, and remained at this level from June to September. Since the combined percentage of stages III and IV amounted to 60% it could be inferred that *L. sanguineus* spawn in these months. However, data collected in November 1971, showed that some individuals had GI of around 30, indicating that there may be a prolonged spawning period from March to the end of the year.

3.3.3 Biological minimum size

From the fishery biology point of view, the words "biological minimum size" here is used to mean the minimum size at which a significant part of a population participates in spawning for the first time.

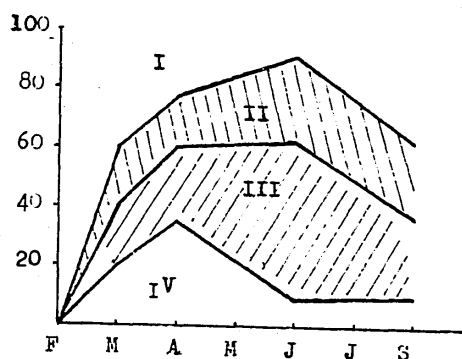

Fig. 5 Monthly change of different class gonad index (cumulative percent)

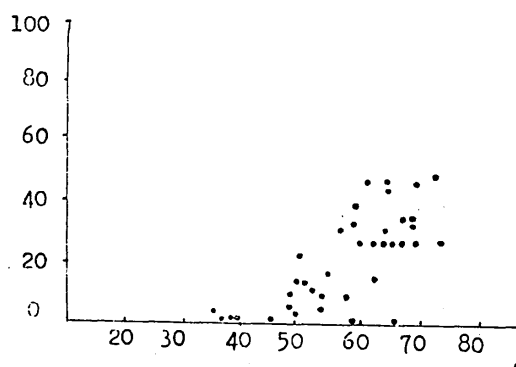

Fig. 6 Relationship between size of fish and gonad index.

Since the highest average gonad index and the highest percentage of stage IV gonads occurred in April, the individual values of gonad indices in April were plotted against the total length of fish. Fig. 6 shows that fish smaller than 50 cm in total length belonged to stage II, the highest gonad index for these fish being 10. The data in June and September were also examined in the same way. Here again, the highest gonad index for fish less than 50 cm was 3 in June and 11 in September.

The biological minimum size of *L. sanguineus*, therefore, may be considered as 50 cm.

3.3.4 Fecundity

In order to study egg distribution within an ovary, the technique described by Kipling & Frost (1969) was followed. Ten counts of 1-g samples, five from each of the paired ovaries, were obtained from different parts of the ovaries of a fish of 58.3 cm in total length and 3.0 kg in weight, caught in April 1971.

The location of each part and the result of counting are shown in Fig. 7. The average number of eggs per sample was approximately 400 and the differences in the number between parts were less than 5%. There was also no significant difference between countings of each of the paired ovaries. These ten 1-g samples were later used for examination of ovarian egg size.

In subsequent study on fecundity, only 4 counts of 1-g samples, 2 from each ovary, were made. Total number of ovarian eggs were estimated by multiplying the mean of 4 counts by weight in gram of ovaries. The estimations were done for 10 females ranging 522–736 mm in total length and 1.7–5.8 kg in weight. The number of ovarian eggs increased with the increase in body weight (Fig. 8), from 691,000 to 2,620,000 eggs as shown in Table III. The regression of the number of eggs in thousands on the body weight of the fish in gram were calculated by least square method with resulting equation:

$$N = 0.4459 W + 93.2$$

where N = number of eggs in thousands
W = body weights (g)

3.3.5 Size distribution of ovarian eggs

As mentioned above, the size of eggs sampled from 10 different parts of the ovaries was measured.

The diameter of eggs ranged from 0.20 to 0.86 mm and two modes in each of the 10 parts were recognized. In almost all samples, the smaller mode was 0.40–0.45 mm and the larger one at 0.70–0.75 mm (Fig. 9). According to the result of χ^2 -test, there was no significant difference between size frequency distributions of any two parts.

Among the two normally distributed groups of eggs, the eggs of the larger group were all transparent.

3.3.6 Spawning season

The seasonal change of the ovaries both in the average gonad index and in the percentage of gonads of advanced stages showed that the spawning must have occurred during the period from April to November, with at least one peak being in April to June. Due to lack of information about ovarian conditions during the months from October to February, it is too early to conclude that April to June is the only main spawning season of *L. sanguineus*.

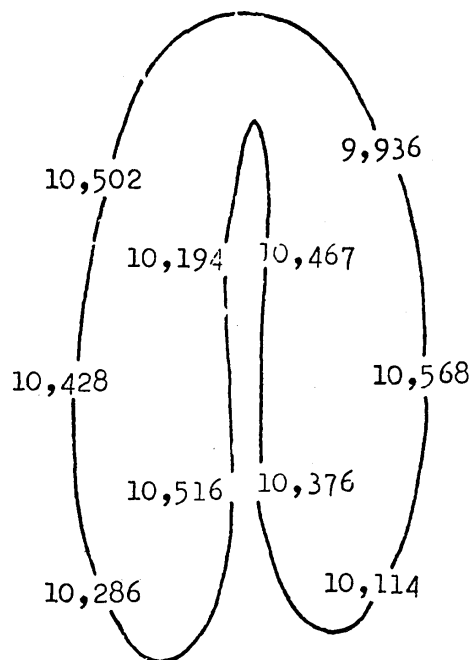

Fig. 7 Diagram of the ovaries of *L. sanguineus*, 58.3 cm in total length, 3.0 kg in wt. showing the position of sampling and number of eggs per grams in each sample.

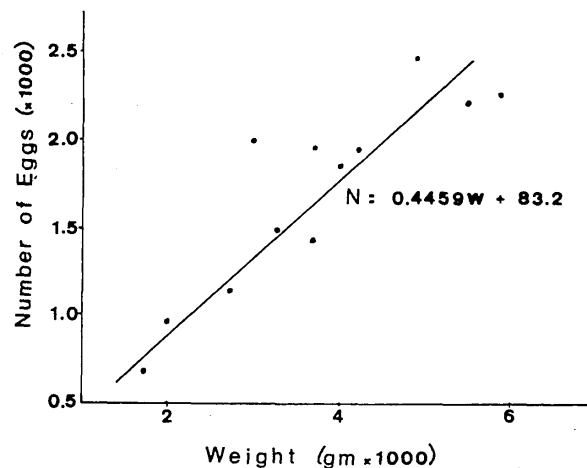

Fig. 8 Relationship between number of eggs ($\times 10^3$) and fish weight (grams).

Table III. Fish size and calculated egg number

T.L. (mm)	Wt. (gm)	Ovary wt.	Estimated no. of eggs ($\times 10^3$)
566	2750	86.99	1,150
583	3600	239.42	2,040
736	5800	158.90	2,280
645	3600	159.65	1,980
690	4900	230.30	2,620
636	3700	104.20	1,440
670	4000	141.80	1,870
642	4200	158.35	1,960
590	3200	122.74	1,500
522	1700	81.60	691

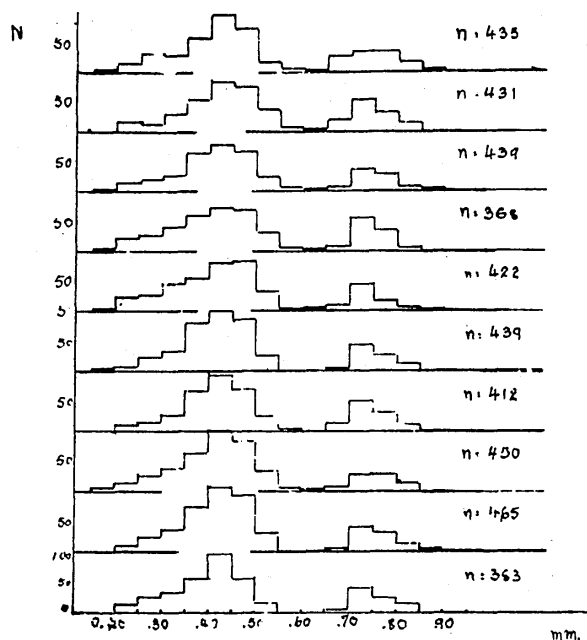

Fig. 9 Distribution of egg size in ten samples from the ovaries of a *L. sanguineus* individual.

The study on the larval fishes in the South China Sea by Yong (1971) and Vatanachai (1971) revealed that lutjanid larvae occurred from June to November, most abundantly in August, although species identification was not yet established.

Since fish schools are usually denser during the spawning season the very high degree of patchiness in geographical distribution of *L. sanguineus* observed in May suggests that the main spawning season occurs in this month.

In considering the various factors mentioned above the months of April, May and June can be regarded as the main spawning season or, at least, one of the two or three spawning seasons.

3.4 Feeding Habit

This topic is discussed in a separate paper (Senta and Peng, 1973). The following summarizes the results.

The main categories of food organisms of *L. sanguineus* were fishes, crustaceans and molluscs. Small-sized demersal fishes were the most important food items. Among crustaceans, small to medium sized crabs were the most important, followed by various species of stomatopods. Shrimps were only important for the juvenile and smaller fish of the species. Cephalopods were only members of significant importance among molluscs.

The feeding habit of *L. sanguineus*, however, was found to be rather flexible. Under certain circumstances, they were found to feed on almost every kind of benthic organisms. All stomachs of the fish caught off the southern coast of Vietnam in September 1971 were full of one kind of tunicate, *Botrylloides* sp.

On the other hand, *L. sanguineus* were not found in the stomach contents of various species of piscivorous fishes such as *Saurida* and *Rachycentron* which also occurred in the fishing ground. There was also no evidence of cannibalism of the species.

In a word, *L. sanguineus* occupied the highest niche in a food pyramid among the bottom fauna.

4. DISCUSSION AND CONCLUSION

Most of *L. sanguineus* caught by trawl fishery in the South China Sea were considered to be about 3 years old and above their biological minimum size.

Size frequency distribution (Fig. 2) showed that the most prominent peaks were near the larger end of the body size range. This suggests that the habitat of smaller fish may differ from that of larger fish, and may occur in some place other than the fishing ground for trawl fishery. The presence of these equally prominent peaks over the range of body size may indicate the comparatively low mortality rate of the species during the first few years of their lives.

The existence of less prominent peaks, or sometimes the existence of too many equally prominent peaks, suggests that there may be some subage groups within one age group. This may be a consequence of a long, dragging spawning season or several spawning seasons in a year.

Since they have not been found to be subjected to predation by other piscivorous fishes and since their feeding habit is rather flexible it can be said that they occupy the highest position in the food pyramid of the bottom fauna.

It may also be said that *L. sanguineus* is well protected from overfishing by trawling. The fact that they tend to seek for habitat in the Neptune's cup zone suggests that a certain part of its population is living in untrawlable areas. Also, as their distribution spreads over a wide area and is not concentrated in a restricted fishing ground for trawl fisheries they are further protected from overfishing.

References

- Harding, J. A. 1949. The use of probability paper for the graphical analysis of polymodal frequency distribution. *J. Mar. Bio. Ass. U.K.* N.S. 28(1) p. 141-153.
- Klipling, C. & W. E. Frost 1969. Variation in the fecundity of Pike *Esox Lucius* L. in Windermere. Reprint from *J. Fish. Biol.* (1969) 1, 221-237.
- Senta, T. and C. C. Peng. 1973. Studies on the feeding habits of red snappers, *Lutjanus sanguineus* and *L. sebae*. Paper submitted to SEAFDEC Seminar, May 1973, Bangkok.
- Vatanachai, S. 1971. Identification of eggs and larvae of fish obtained from the survey cruises in the South China Sea. Report submitted to Southeast Asian Fisheries Development Center.
- Yong, C. T. 1971. Preliminary study on the occurrence of fish larvae, fish eggs and its ecology in the South China Sea. Report submitted to SEAFDEC.

Records of Echo-Sounder Tracing as Guide to Locate and
Evaluate Good Fishing Grounds*

by
Akihiko Shiota

Marine Fisheries Research Department
Southeast Asian Fisheries Development Center
Changi Point, Singapore

Abstract

An echo-sounder is an effective method of location and evaluation of fishing grounds, although its scope of coverage is narrow and the intensity of its echogram tracing as a means of estimating the size of fish schools is still a problem.

Approximately 800 hours of echo-sounder recordings made in the South China Sea and Andaman Sea during the survey cruises of R/V CHANGI from 1970 to March 1973 were analysed. The results show that there is a definite correlation between fish catch and the gradings of fishing grounds as evaluated from the echograms obtained from the same area. This is especially so in areas where the values of mean catch per hour are more than 200 kg.

The presence of upwelling, current rip and boundary layer, important factors for the formation of good fishing grounds can be clearly detected by an echo-sounder.

During drifting, the growing size of fish schools attracted to the vessel's light in the hours of darkness, as appeared on the echogram, may indicate abundance of fish in that area.

The different modes and types of fish schools of some large fishes are easily recognisable on the echograms.

1. INTRODUCTION

An echo-sounder is one of the popular devices used for locating fish schools. Based on the study of echogram and the biology of fish schools the echo-sounder has made invaluable contribution to the promotion of fisheries development. As the correct interpretation of echo-sounder tracings is important in fisheries resources and oceanographic studies, an attempt is made to correlate the echogram records collected by R/V CHANGI since January 1970 with data on fish catch and environmental factors.

2. MATERIALS AND METHODS

The echo-sounder used is the Sr-11 type of 200 KC frequency made by Kaijo Electric Co. Ltd., Japan. Approximately 800 hours of recorded echogram were made and classified into run and drift records. Only spot traces representing more than 6 m² as calculated from the

echogram were considered as fish schools. The degree of fish abundance based on the number of fish schools observed on 30 minutes continuous record of echogram per mile was graded as follows:-

Grade	Fish abundance	No. of fish schools
IV	Very abundant	> 7
III	Abundant	4 - 7
II	Common	2 - 3
I	Rare	1
0	Absent	0

Separate evaluation of fish schools was made of run and drift records and graded in numbers to each half-a-degree block. Actual fish catch was also calculated to mean catch per hour for each half-a-degree block. The numbering system of block is as previously described (Anon., 1971).

Wherever possible, handline fishing was deployed to sample the fish in the vicinity where fish schools were recorded on the echogram for identification.

3. RESULTS

3.1 Fish schools and echogram

Table I illustrates the catch per hour for each haul obtained by CHANGI in April 1971 and the degree of abundance of fish schools as evaluated from the echogram by the method mentioned in 2. Similarly, high mean catch per hour (>200 kg) in areas where sounding records were since 1970 and the degree of abundance as evaluated from the echograms (Plate 1, A-D) are shown in Table II.

The result of the relationship between the evaluation and actual catch and their correlation is shown in Table III. The percentage of occurrence at different catch range is shown in figure 1.

From the result of analyses, there is a definite correlation between the actual catch and the evaluation of degree of fish abundance based on the records of echogram.

Some fishes are known to be attracted by light during hours of darkness. Echograms were continuously recorded during a 25-hour observation in April 1972 at a fixed position. Observation showed that during the day very few fish schools were recorded. However, there was a general upward movement of fish schools towards CHANGI's light shortly after dark and the size of schools, depending on the fish population in the area, grew with time. This

* We regret that it is not possible to publish the original "Plates" as their condition is no longer suitable for printing.

size increase of fish schools, which can be recorded and evaluated by echograms, may serve as an indicator of fish abundance in the area. Plate 2 (A & B) show the fish schools as appeared on echograms in the day and nighttime; at the same position, and plate 2 (C & D) show the pelagic and demersal fish schools being attracted to the vessel's light during the nighttime. Similarly, during the vertical handline fishing cruise carried out in February 1973 in the Andaman Sea, a large school of skipjack tuna was recorded on the echogram at night (Plate 2E). Angling by the crew and scientists on board CHANGI brought in several skipjack tuna.

The different modes and types of fish schools of some large demersal fishes are easily recognisable on echograms. Plate 3 (A & B) shows the presence of a large fish school and the features formed by vertical handline fishing. From the composition of fish catch thus obtained (Fig. 2), it was estimated that the fish school consisted mainly of white snapper.

3.2 Current rip and echogram

A current rip is formed when two masses of water having different physico-chemical properties meet. In Sibul Bay, a current rip was seen for miles on several occasions during the November cruise of CHANGI in 1972. The water on the coastal side of the current rip was yellowish green with surface salinity of 23.5‰ whereas on the other side of the current rip, the water was light blue with surface salinity of 30. Echo-sounding records were made as the vessel moved in a zig-zag fashion crossing the rip on several occasions. As shown in Plate 4 a thick dark band appeared at the surface of the echogram when the vessel crossed over the rip. According to the analysis by Ishida et al (1960) current rip is made up of high concentration of plankton, suspended particles and air bubbles.

Similarly, a boundary zone can also be detected by echo-sounder (Plate 5).

3.3 Upwelling and echogram

Upwelling has been known to occur in the Andaman Sea during the northeast monsoon (Wyrтки, 1961). During the exploratory fishing by vertical handline in February 1973 at the eastern part of the Andaman Sea, the echo-sounder was engaged for locating fish schools (Plate 6) in untrawlable fishing grounds (Senta *et al*, 1973). During this survey, although the sea was very calm, many white caps were seen on the sea surface suggesting the presence of internal waves. These were seen on the sea surface suggesting the presence of internal waves. These were distinctly displayed on the echogram (Plate 7) recorded at the area around the shoulders of the continental slope.

It is interesting to note that the dark bands on the echogram were actually scattering layer of concentrated zooplankton and that the form of waves were the result of current coming from the deeper water. This evidently indicated the occurrence of upwelling.

4. CONCLUSION

From the above discussion it can be seen that the echo-sounder is an indispensable device not only for locating fish schools but also for the studies of environmental factors which may be important in the formation of fishing grounds.

Table II. Good catch (>200 kg/hr) and degree of fish abundance as evaluated from echograms in the South China Sea and adjacent waters, 1970 - 1973

Date	Mean catch/hour (kg)	Fish abundance evaluated from echograms
1970 May	266.8	3
"	218.3	2
"	248.3	3
"	266.3	3
June	440.0	4
"	342.0	4
July	305.3	3
Oct.	282.4	3
"	235.5	3
"	202.4	3
"	311.3	3
Nov.	213.3	3
"	250.3	3
1971 Aug.	210.3	3
Oct.	325.1	3
"	240.4	3
Nov.-Dec.	232.3	3
"	215.6	3
"	292.3	3
"	203.1	3
"	211.2	3
"	243.1	3
1972 Jan.	478.0	4
"	215.5	3
"	244.8	3
Sept.	212.8	3
Oct.	200.6	2
"	257.0	3
"	207.7	3
"	293.7	3
Nov.	241.9	3
Dec.	437.2	4
"	461.7	4
1973 Jan.	440.0	4
Feb.*	245.7	3
Feb.	627.9	4
Feb.*	384.1	4

* by the bottom vertical handline fishing (kg/hr/50 hooks).

Table III. Correlation between echogram gradings and actual fish catch.

Degree of fish abundance evaluated from echograms (nos)	Actual catch		Correlation	
	No. of samples (N)	Mean (\bar{x}) kg/hr	Range (kg/hr)	Probability %
0 - I	23	67.7	0-80	88.8
II	18	105.7	80-180	77.7
III	32	203.8	180-320	100.0
IV	8	451.0	>320	100.0

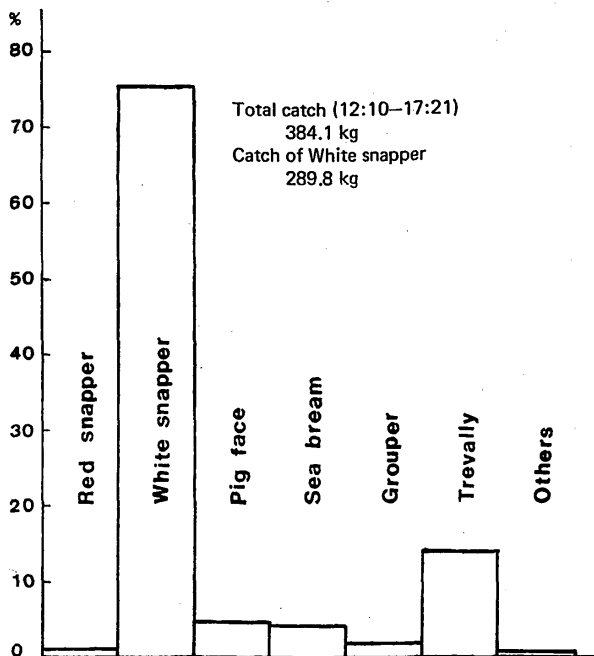

Fig. 2: Composition of the fishes obtained by vertical Handline fishing in the eastern part of the Andaman Sea in February 1973.

SEAFDEC/SCS.73: S-19

A Study of the Catch Data of the JURONG in the South China Sea in 1971 and 1972

by

Hooi, Kok Kuang

Marine Fisheries Research Department
Southeast Asian Fisheries Development Center
Changi Point, Singapore

Abstract

The semi-commercial bottom trawl fishing by the training vessel JURONG in the South China Sea in 1971 and 1972 was confined to three areas at its south western portion. The positively skewed frequency distributions of catch per hour assumed approximately the shape of a normal curve when the yield was transformed logarithmically. Sample statistics from these transformed values form the basis of discussion of the yields for 1971 and 1972 in relation to fishing seasons and types of nets used.

Yield records from JURONG showed that the catch in waters off Trengganu (northeast coast of West Malaysia) was poorer than that of Tioman and Sarawak. These yields were briefly discussed together with values obtained by the R/V CHANGI. In the area off Sarawak, the Engel II net obtained much better catches than the four seam net.

The percentage composition of dominant fish categories from Tioman and Sarawak are also discussed.

5. ACKNOWLEDGEMENTS

The author expresses his heartiest thanks to Mr. Chen Foo Yan, Chief of the Marine Fisheries Research Department, SEAFDEC, for reading the manuscript and giving valuable criticism. The author also extends his thanks to Mr. Mathew Chow for his valuable technical assistance.

References

- Anonymous Report for 1970 of Marine Fisheries Research Department, SEAFDEC, 1971.
Senta, T., C. Miyata and S. M. Tan, 1973. Demersal fish resources in untrawlable waters, viewed through vertical-line fishing. Paper submitted to SEAFDEC Seminar, May 1973, Bangkok.
Wyrtki, K., 1961. Physical oceanography of Southeast Asian Waters. Naga Report, Volume 2, The University of California, Scripps Institution of Oceanography.
Ishida, M., T. Suzuki, N. Sano, I. Saito and S. Mishima, 1960. On the detection of the boundary zone. *Bull. Fac. Fish. Hokkaido Univ.* 10 (4) : 291 - 302.

1. INTRODUCTION

For the purpose of providing shipboard training for the fishing technician trainees of the Fisheries Training Centre a joint Singapore FAO/UNDP project, the training vessel JURONG carried out bottom trawl operations in known fishing grounds in the South China Sea from 1971. The vessel tended to fish in grounds where good catches were anticipated and to continue fishing in grounds where good catches were obtained. The catches could therefore be regarded as semi-commercial in nature and probably good indicators of the conditions at the time the areas were fished.

A study of these catch data, made available to the Marine Fisheries Research Department, Southeast Asian Fisheries Development Center (SEAFDEC), is presented in this paper.

2. BACKGROUND OF DATA

The JURONG, maintained by the Fisheries Training Centre weighs about 210 G.T. and has a 750 h.p. engine.

Fourteen fishing cruises were made to the south western part of the South China Sea in 1971 and 1972 as shown in Table I and Fig. 1. These were to the north of Sarawak, the area around Pulau Tioman and in waters off the northeast coast of West Malaysia (Trengganu). All fishing operations were performed during the day.

During all cruises to off Sarawak in 1972 two types of nets were used the so-called four seam (headrope length 51.5 m) and Engel II (headrope length 75.5 m) nets. These nets were trawled at similar speeds and durations. At all other times and areas only the four seam net was used.

When the catch was landed on deck, the fish were sorted into various categories and weighed separately.

3. RESULTS & DISCUSSION

3.1 Mean catch and variation

The frequency distribution of the catch (in kg/hr) was obtained for each of the groups of cruises of Table I, and their frequency histograms are shown in Fig. 2. They are far from normal in shape. Since the magnitude of the variances, s^2_x , were much greater than that of their means and tended to increase with the mean catch (Table II), a logarithmic transformation (using $\log(x+1)$, where x is the catch in kg/hr) was carried out. The frequency distributions thus obtained appeared to be more normal in shape (Fig. 3) and the variances were stabilised.

The means and variances were calculated for the transformed data and used for deriving the expected frequency distributions of normal curves with the corresponding

numbers of samples, means and standard deviations (Fig. 3). The corresponding observed and expected frequency distributions were compared by the chi-square test. It was found that in each case, the transformed frequency distributions were good fits with the expected at 95% probability level. Hereafter, the transformed data will be used, a logarithmic transformation (using $\log(x+1)$, where x is the catch in kg/hr) was carried out. The frequency distributions thus obtained appeared to be more normal in shape (Fig. 3) and the variances were stabilised.

3.1.1 Sarawak

In the area to the north of Sarawak the mean catch in 1971 was lower than that in 1972. The variance of the catch in 1971 was not significantly different from that of either nets in 1972, but the mean catch was very highly significantly ($P < 0.001$) lower than that of both the four-seam and Engel II nets in 1972 although the fishing grounds were similar.

The better mean catch in 1972 could be due to the longer fishing season in this year. Table II shows that the variance in the 1972 four-seam net catches were larger than that in the 1971 catches. The catch in 1972 was spread over a period of approximately six months (late March through late September) as compared to about three months (late July through early October) in 1971 (Table I). The transformed ($\log(x+1)$) mean catch of the cruises in July and September, 1971 (63 hauls) was 2.0127 (antilog = 103.0 kg/hr) while that of the same months in 1972 (41 hauls) was 2.0869 (antilog = 122.2 kg/hr). Their 68% catch ranges were between 58 and 178, and between 53 and 276 kg/hr respectively; there was therefore quite considerable overlap. The mean catch of all other earlier cruises in 1972 (47 hauls) was 2.3611 (antilog = 229.7 kg/hr) and gave a 68% catch range of 130 to 410 kg/hr; this was much better than that during July and September of both 1971 and 1972, and contributed greatly towards the higher mean catch in 1972.

Table I. The cruises and hauls of the JURONG in the South China Sea in 1971 and 1972

Area & Year	Net	Fishing Dates	No. of hauls
off Sarawak, 1971	4-seam	July, 20-27	24
		Sept. 9-20	39
		Oct. 7-9	9
off Sarawak, 1972	4-seam	Mar., 16-20	8
		Apr., 14-20	28
		May, 12-18	11
		July, 16-23	26
		Sept., 23-27	15
off Sarawak, 1972	Engel II	Mar., 16-20	9
		Apr., 14-20	1
		May, 12-18	19
		July, 16-23	9
		Sept., 23-27	5
off Tioman, 1971	4-seam	Mar., 31 - Apr., 7	35
		Apr., 21-29	39
		July, 18-19	7
		Aug., 7-10	15
off Tioman, 1972	4-seam	Mar., 28-31	18
		Apr., 28 - May, 1	17
		June, 27 - July, 1	8
off Trengganu, 1972	4-seam	June, 28-30	11

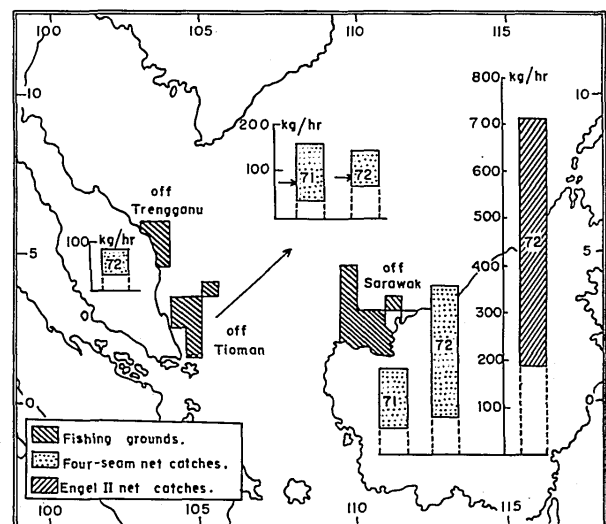

Fig. 1 Areas of fishing by the JURONG in the South China Sea and the histograms of 68% catch ranges (1971 & 1972). The horizontal arrows indicate the geometric mean catch.

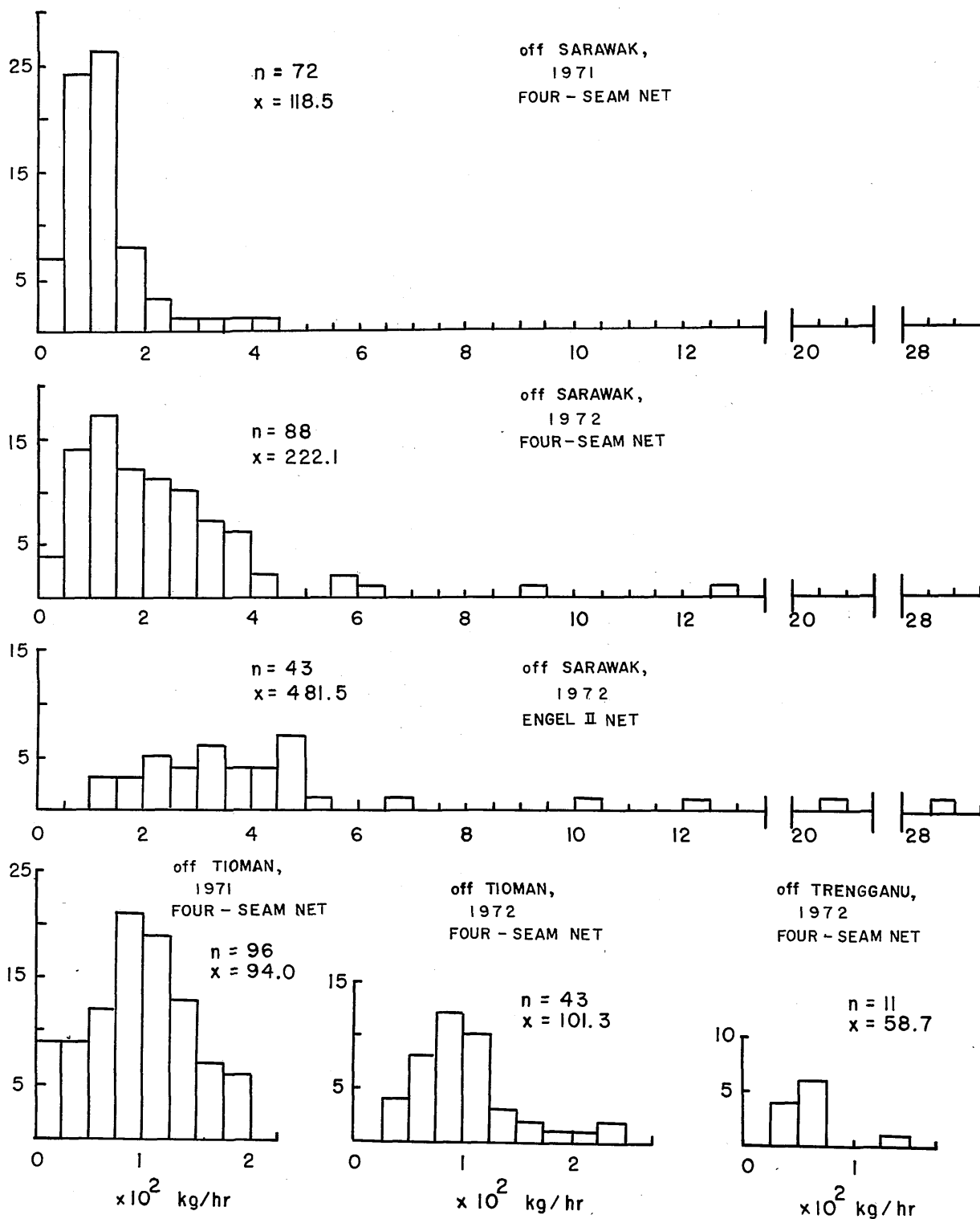

Fig. 2 Observed frequency distributions of catch in untransformed values.

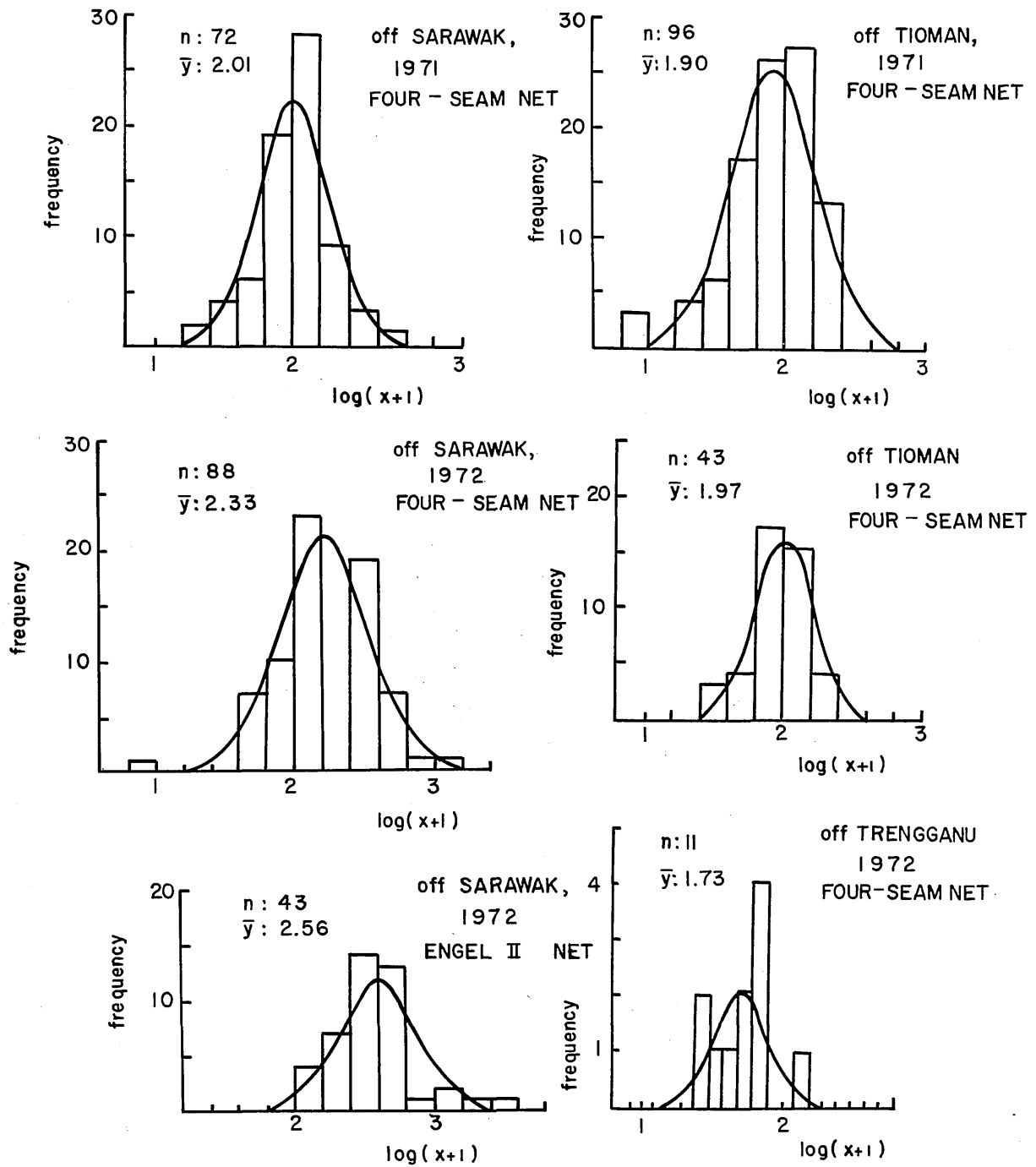

Fig. 3 Observed and expected frequency distributions of catch in logarithmic values.

We can see from Table I that the four-seam and Engel II nets were used in every cruise in 1972 to the north of Sarawak. The variances between the catches by the two nets were not significantly different. But the mean catch between the two nets was very highly significantly ($P < 0.001$) different.

A study of a similar area by Minh (1972) of bottom trawl catches of the research vessel CHANGI of the Research Department, SEAFDEC, using a similar method of analysis gave a geometric mean catch of 113.2 kg/hr. The 68% and 95% catch ranges were between 47 and 270 and between 20 and 645 kg/hr respectively. These values were obtained from 86 hauls taken over two cruises in April and May, 1970 and one cruise in October, 1971 and spread over a much wider area. Moreover, the approach was not similar to that of the JURONG, but was designed to sample from as many locations as possible in a given time. With due consideration to the fact that values obtained from two different vessels are not directly comparable nevertheless it can be seen that the values from the CHANGI can easily be accommodated between the catch ranges of the JURONG taken by the four seam net in 1971 and 1972 (Table II) in approximately the same monsoon season.

3.1.2 Tioman

The catches in the Tioman area in the same years were poorer than those from off Sarawak (Table II; Fig. 1). When the mean catch and variances from the two years were compared it was found that although the difference between the means was not significantly different, the difference between the variances was highly significant ($P < 0.01$).

When the JURONG began fishing in 1971, its first cruise was to the Tioman area. Naturally, the experienced fishermen had to get used to the ship and gear, and simultaneously train the almost completely green crew in bottom trawl fishing. The catch of the first few hauls in the first cruise was poor, and was a source of the comparatively large variance in 1971 as compared to 1972 (Table II). The variance of the first cruise was 0.0953. This was reduced to 0.0256 in the second cruise. The variance

of the fourth cruise to the area was even lower at 0.0109. However, during the third cruise the variance was again high ($=0.1184$), but could have been due to other factors such as species composition (see later).

When fishing was confined to an area about 45 nautical miles square within the Tioman area under discussion, the CHANGI caught an average of 172 kg/hr (geometric mean), with a 68% catch range between 91.9 and 321.0 kg/hr (Anon., 1972). The narrow strip of ground was covered systematically by 99 hauls between late 1971 and early 1972 and again in October 1972. With reference to the JURONG's 68% catch range in Table II, the CHANGI had much better catches and much wider catch range, though it may not be strictly proper to compare directly, since the CHANGI fished in the restricted area during the northeast monsoon while the JURONG visited during the southwest.

3.1.3 Trengganu

In the lone fishing cruise to the area off Trengganu in late July, 1972 the average catch was poorer than that from around Tioman in 1972. To a large measure this was due to the type of fishing – the fishing off Trengganu was highly exploratory, covering in the eleven hauls an area approximately more than half that covered around Tioman with 43 hauls in 1972 (see Fig. 1; Table I). However, the transformed mean ($= 1.7266$) was not significantly different from that taken off Tioman ($= 1.8529$) during the same cruise (8 hauls). Nor were the differences between their variances significantly different. It may, however, be highly suspect to draw inferences from such a small sample size from this area.

3.2 Species composition

3.2.1 Sarawak

The species composition of fish caught off Sarawak was studied to see if the differences in mean catch between 1971 and 1972 were related to various fish categories and to see whether the nets used showed any selectivity.

In Table III, the percentage composition by weight of fish categories caught off Sarawak is shown. Thirty-two groups of fish were recorded in 1971. In 1972 thirty-seven

Table II. Summary of statistics of trawl catch by the JURONG in the South China Sea during 1971 and 1972.

Item	Area:		off Sarawak		off P. Tioman		off Trengganu
	Year	1971	1972	1972	1971	1972	1972
	Net	Four-seam net		Engel II	Four-seam net		Four-seam net
Number of hauls, n		72	88	43	96	43	11
Arithmetic mean, \bar{x}		118.5	222.1	481.5	94.0	101.3	58.7
variance, s_x^2		5352.1	3444.1	259311.2	2104.0	2330.8	965.8
Transformed mean, y		2.0067	2.2334	2.5649	1.9020	1.9664	1.7266
[long (x+1)] s_y^2		0.0638	0.1081	0.0834	0.0905	0.0389	0.0476
Sy		0.2526	0.3288	0.2888	0.3008	0.1972	0.2181
Derived values:							
Geometric mean		100.6	170.2	366.2	78.8	91.6	52.3
Catch ranges:							
68% (Lower Limit		58.8	79.3	187.8	38.9	57.8	31.3
(Upper Limit		180.7	364.0	713.1	158.5	144.7	87.0
95% (Lower Limit		30.7	36.7	96.1	19.0	36.3	18.5
(Upper Limit		324.0	777.0	1388.0	317.8	228.5	144.5

Table III. Percentage composition by weight (untransformed values) of major fish categories caught by JURONG off SARAWAK in 1971 and 1972.

Categories of fish	1971	1972	
	4-seam	4-seam	Engel II
Red snapper	24.3	9.5	4.7
Threadfin snapper	7.5	1.3	8.9
Thick-lip grunt	5.2	0.5	0.1
Slender shad	—	12.9	15.1
Shark	5.9	4.9	3.0
Trash	29.3	35.9	41.4

groups were recorded for the four-seam net catch and thirty-six for the Engel II catch. The table shows arbitrarily only those fish categories which amounted to or exceeded 5% of the catch in any one set of data, as they are most likely to influence the total catch.

In 1971 there was greater occurrence of red snapper and thick lip grunt but a lower proportion of trash fish than in 1972; no catch of slender shad was recorded in 1971. The catch in the CHANGI indicated that slender shad was caught in waters with much coastal influence (Anon., 1972), and indeed in 1972 the JURONG tended to fish nearer the coast, where catches were also usually better. In 1971, about 25% of the hauls were taken off coastal waters, whereas in 1972 this increased to about 80%.

In 1972, the Engel II net caught 8.9% of threadfin snapper by weight but only 1.3% was recorded in the four seam net's catch. The four seam net caught 7.5% of the fish in the same area in 1971 and had good catches of threadfin snapper in the Tioman area in 1971 and 1972. Apart from this the catch by the four-seam and Engel II nets were not sufficiently different to suggest selectivity of dominant fish categories in this area conducted at the time, and it appeared that the Engel II net was capable of producing a higher yield.

3.2.2 Tioman

The catch composition from around Tioman was studied in relation to the differences in the variances (transformed values) between 1971 and 1972. Thirty groups of fishes were recorded in 1971, but seven of these groups whose occurrence was more than 5% of the catch in either year, as shown in Table IV, occupied 71.2% of the total

catch. In 1972 there were only three groups (out of a total of 31 recorded) of fishes which occupied more than 5% of the catch, and these groups constituted 45.6% of the total catch.

The areas fished in 1971 and 1972 were almost the same, and the percentage by weight of red snapper and triggerfish were very similar. However, the percentage occurrence of all other groups, except threadfin snapper, were much larger in 1971 than 1972 (Table IV).

The variation of catch from haul to haul was calculated for each of the fish categories occurring in more than 5% of the total catch. The variances for triggerfish and threadfin snapper were larger in 1971 than 1972, in spite of the larger proportion of these fishes in the catch in 1972. There were also other fairly large sources of variations in the catch from the other four major fish categories. Therefore the effect of the larger variation of the catch of red snappers in 1972 (as compared to that of 1971) was easily suppressed in the total variation: the variance (transformed values) of the combined weights of fish categories listed in Table IV was 0.1505 in 1971 and 0.0759 in 1972.

Although no observations were made it may be possible to regard the differences in the variation of catch from haul to haul in the two years as possibly due to the behaviour or distribution of fish schools in the area.

4. CONCLUSION

The JURONG fished in three south western areas of the South China Sea during 1971 and 1972. Most of the fishing was in the south west monsoon. However, there is insufficient information for conclusions of more than a tentative nature regarding these areas and their yields in terms of sample statistics and not of population parameters. It appears that the yield from off Sarawak was better than that from off Tioman, which in turn was better than that from off Trengganu. But the intensive fishing by the CHANGI during the north east monsoon season indicated that the yield from off Tioman could be similar to that from that off Sarawak in the south west monsoon.

The yield off Tioman in 1971 and 1972 was very similar. But the yield off Sarawak in 1972 was higher than 1971. The higher mean catch by the four-seam net off Sarawak in 1972 over that in 1971 was largely due to higher catches in the earlier parts of 1972 and its concentrated effort in coastal waters. There was substantial agreement in the mean catch of the CHANGI which sampled

Table IV. Percentage composition by weight (untransformed values) and variances in catch (logarithmic values) of major fish categories caught by JURONG off Pulau Tioman in 1971 and 1972

Fish Categories	1971		1972	
	Percentage composition	Variance (s_y^2)	Percentage composition	Variance (s_y^2)
Red snapper	21.9	0.3528	22.0	0.4259
Naked headed seabream	5.7	0.3552	1.7	—
Triggerfish	7.4	0.3763	8.8	0.1711
Threadfin snapper	10.9	0.6499	14.8	0.6279
Bigeye snapper	8.7	0.4658	0.8	—
Shark	8.0	0.5267	3.8	—
Trashfish	8.6	0.5926	2.5	—

over a much wider area and time span in the same monsoon season. When it was used, the Engel II net caught more fish off Sarawak than the four-seam net in 1972, and appears to be more effective for fishing in this area; it was not tested in other areas. It is likely that the net will be experimentally tested in the near future.

The variation in the catch from haul to haul in the Tioman area was greater in 1971 than in 1972. Part of this was due to the poor catch of the first few practice hauls with the new boat and also partly due to the larger variation of catch of many more dominant fish categories, possibly as a consequence of differences in fish schooling behaviour.

SEAFDEC/SCS. 73: S-26

The Demersal Resources of the South China Sea

by

Liu Hsi-Chiang
Demersal Fish Research Center
Institute of Oceanography
National Taiwan University

Abstract

Based on the catch statistic derived from the official returns which were offered from all Taiwan paired trawlers operated in the South China Sea, dating from 1969 to 1971, the author made an investigation on the species composition, the seasonal changes of the demersal fishes appeared in their catches. The magnitude and potential of the demersal fish resources in these areas have also been assessed.

1. TOPOGRAPHY

As defined here, the northern boundary running to the north of Taiwan (25°N. 124°E), the western and southern boundaries are the mainland coast of Asia and the Malay Peninsula to 100°E, thence south to the equator, and along the equator to 117°E.

The region may be divided into seven sub-areas: the Taiwan Strait, the shelf of the Chinese south coast, the Gulf of Tongking, the Gulf of Thailand, the shelf off the Vietnam coast, the shelf off the Eastern coast of Malay Peninsula, the shelf off the northern coast of Borneo (Fig. 1).

The region includes a narrow continental shelf in the eastnorthern part and a wide area of continental shelf in the westsouthern part. These are given in Table 1 (with approximate areas in KM² to the 200 m contour).

Niino and Fmery (1961, 1963), Emery (1969) made a general distribution map of sediments in the continental shelf of the South China Sea, Taiwan Strait and the Gulf of Thailand (Fig. 2). Sands are predominant distribution in the central portions of Taiwan Strait, the shelf off the South Vietnam coast, and some narrow sandy areas are

5. ACKNOWLEDGEMENTS

Thanks are due to the Project Manager of Fisheries Training Centre, Singapore, and the Director of Primary Production, Singapore, for release of the data of the JURONG.

References

- Anonymous. 1972. Quaterly Newsletter, No. 6, Marine Fisheries Research Department, SEAFDEC, Oct.—Dec., 1972.
- Trang Quang Minh. 1972. Trawl fishing conditions in the South China Sea and its adjacent seas. Graduation thesis (unpublished) presented to Marine Fisheries Research Department, SEAFDEC

present on the outer half off the Chinese south coast, northern coast of Borneo, and central east coast of Malay Peninsula.

Muds occur along Taiwan and the Chinese southeast coast to the inner shelf off the South China and the Gulf of Tongking, are predominantly distributed in the Gulf of Thailand, the shelf between Malay Peninsula and Borneo. Rocks are common on the irregular narrow shelf off Vietnam, southeast part of the Gulf of Thailand adjacent to Cambodia Coast, around the Natuna islands, around the Penghu islands in Taiwan strait, and outer shelf South of Hong Kong.

Table I. Areas of shallow water in the South China Sea (under 200 m)

Area	km ²
Taiwan Strait (Region 3)	131,000
Chinese south coast (Region 4)	217,000
Gulf of Tongking (Region 5)	202,000
Gulf of Thailand (Region 6)	332,000
Coast of South Vietnam (Region 7)	245,000
East Coast of Malaysia (Region 8)	378,000
North coast of Borneo (Region 9)	249,000

2. FISH STOCKS AND FISHERIES

2.1 Trawling Fisheries of Taiwan

There are three types of trawling fisheries in Taiwan: (1) Drag-net fishery: The trawler is below 50 tons. It has 2,480 netters weighing 42470.39 tons, landing 98685 mt. products in 1971*. The main fishing grounds are in Taiwan Strait. (2) Otter trawl fishery: The trawler is above 50 tons. It has 163 trawlers weighing 20235.22 tons, landing 56580 mt. products in 1971*. The main fishing grounds are around the East China Sea and Taiwan Strait. (3) Paired trawl fishery: The trawler is also above 50 tons. It has 317 trawlers weighing 39949.65 tons, landing 140814 mt. products in 1971. The main fishing grounds are around the South China Sea and the water surrounding Northern Australia.

2.2 Statistics of Taiwan Trawling Fisheries

The fishing ground of the South China Sea has been demarcated into seven regions with every unit block of half degree square. Every trawler of above 50 tons has been expected to turn in the log book report as the original reference after each voyage. These reports will then be collected by the field stations of Demersal Fish Research Center at Keelung and Kaohsiung fish market. In the log book information such as exact date, position of trawling, daily working haul number, and daily datches of each species have been recorded carefully. All of the collecte data have been well arranged to get effort and catch statistics by area. This work has been in progress since 1970. A more efficient systematic data processing system with computer routine will be set up.

2.3 Stocks assessments for exploited stock

Fishing effort, total catch, and unit catch of Taiwan paired trawling fishery in the South China Sea is shown in Table II. The annual changes of fishing effort of each major fishing ground from 1969 to 1971 shows a little increment in region 6,8,9, but a great increment in region 7, and on the contrary, a great decrement in region 3,4,5. Generally speaking, the fishing efforts decreased gradually in the northern neritic area of the South China Sea and relatively increased gradually in the southwest neritic area of the South China Sea. It indicates that some trawlers which operated in the northern neritic area of the South China Sea extended gradually more and more southward. Comparing the yearly total fishing effort among different regions in 1971, it shows that region 3 hold they first position, 41% of the total. Following is region 7 with 22%, region 4 with 12%, region 5 with 10%, region 6 with 5%, region 9 with 5%, region 8 with 4%. The annual changes of total catches in each regions are proportional to the total fishing efforts expended. In region 3,4,5, there seems a decline in catch from year to year. On contrary, in region 6,7,8 and 9 reveal a increment in catch. Comparing the yearly total catch among different regions in 1971, it shows that region 3 hold the first position, 35% of total, region 7 with 26%, region 4 with 11%, region 5 with 10%, region 9 with 6%, region 8 with 6%. The unit catch among these years in each regions shows a little variety. In comparing the unit catch among different regions in 1971, it shows that there are nearly same

* Adapted from Fisheries Yearbook of Taiwan Area 1971

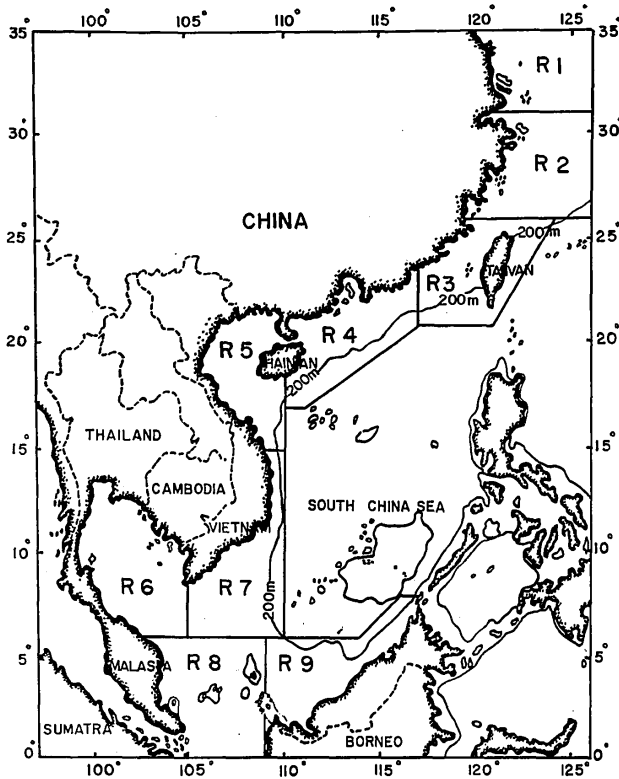

Fig. 1 Fishing grounds of Taiwan Trawling Fisheries.

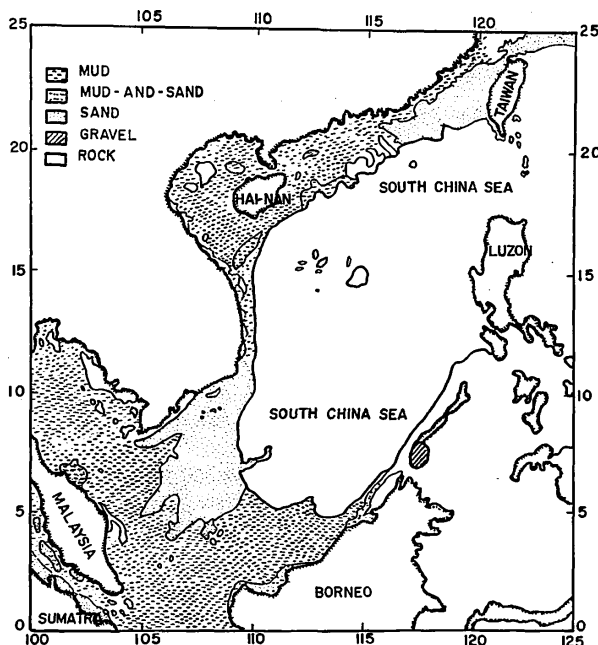

Fig. 2 Sediments chart of shallow portions of the South China Sea. (From Niino and Emery 1961, 1963, and Emery 1969)

Table II. Fishing effort, total catch, and unit catch of Taiwan paired trawling fishery in the South China Sea from 1969 – 1971.

Region	Fishing effort (Haul)			Total catch (Cases*)			Unit catch (Cases per haul)		
	1969	1970	1971	1969	1970	1971	1969	1970	1971
R3	95,021	78,932	65,790	1,490,254	1,298,646	1,152,439	15.65	16.45	17.52
R4	38,702	32,718	19,511	704,656	589,167	357,199	18.21	18.01	18.31
R5	24,482	29,130	16,482	521,250	674,901	318,776	21.29	23.17	19.34
R6	235	301	9,037	7,472	5,732	240,450	31.80	22.66	26.61
R7	11,710	23,103	34,453	353,082	568,095	851,000	30.15	24.59	24.70
R8	17	516	6,512	500	11,817	169,760	30.59	22.90	26.07
R9	115	3,020	7,094	4,056	87,200	188,520	35.27	28.87	26.57
Total	170,282	167,720	158,879	3,081,270	3,235,558	3,278,198	18.10	19.29	20.63

* One case \approx 26 kg

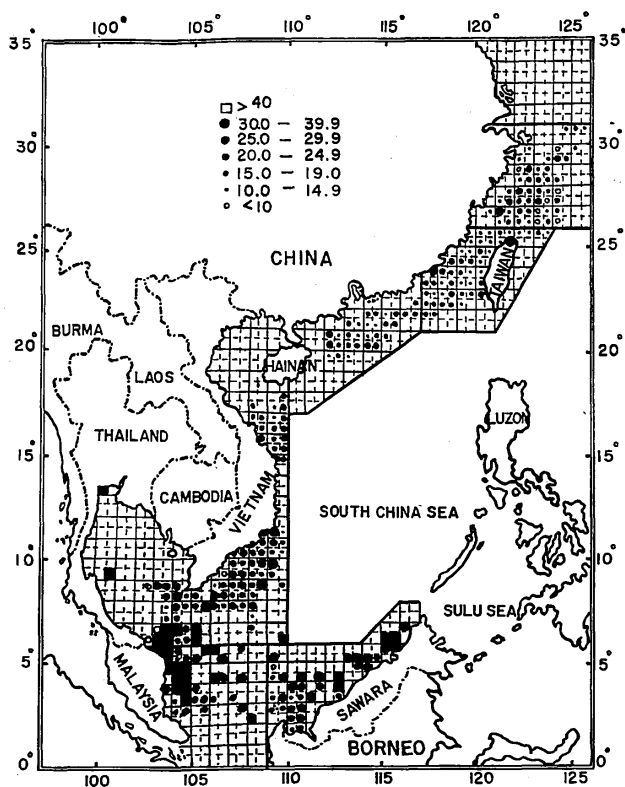

Fig. 3 Distribution of unit catch in cases per haul for ground fishes caught by Taiwan paired trawling fishery, from 1970 to 1971.

value about 26 cases per haul in region 6,7,8,9 and about 18 cases per haul in region 3,4,5. The value of unit catch in the northern neritic area of the South China Sea is about 3/4 of the southwest neritic area of the South China Sea.

2.4 The species composition of each region

The comparison of the species compositions among different regions. As shown in figure 4, the main species of region 3 are: hail-tail, *Trichiurus haumela* (species number 3); lizard fish, *Sauridatumbil* (sp. no.8); cuttle fish, (sp. no. 8); golden thread, *Nemipterus flaviventris macracanthus* (sp. no. 1); white croaker, *Agyrosomus macrocephalus* (sp. no. 21); etc.

In region 4, the main species are: golden thread, *Nemipterus mesoprion* (sp. no. 24); golden thread, *Nemipterus virgatus*(sp. no. 20); big-eye, (sp. no. 1); lizard fish, (sp. no. 8); golden thread, *Nemipterus flaviventris* (sp. no. 14); etc.

In region 5 they are: red mullet, *Upeneus bensasi*, (sp. no. 2); yellow sea bream, *Dentex tumifrons* (sp. no. 22); lizard, fish (sp. no. 8); malabar snapper, *Lutjanus malabaricus* (sp. no. 6); big-eye; golden thread (sp. no. 20); etc.

In region 6, they are: big-eye; lizard fish, *Saurida elongatus*, (sp. no. 9); sea catfish, *Ariidae spp.*, (sp. no. 4); golden thread (sp. no. 14); malabar snapper (sp. no. 6); etc.

In region 7, they are: lizard fish, *Saurida undosquamis*, (sp. no. 7); cuttle fish (sp. no. 5); golden thread, *Nemipterus marginatus*, (sp. no. 15); big-eye; common squid, *Loligo spp.*, (sp. no. 12); etc.

In region 8, they are: big-eye; red mullet (sp. no. 2); lizard fish (sp. no. 9-; sea catfish (sp. no. 4); amberfish, *Decapterus maruadsi* (sp. no. 10); malabar snapper(sp. no. 6); etc.

In region 9, they are: sea catfish (sp. no. 4); golden thread, *Nemipterus nemurus*, (sp. no. 18); pompanos, *Caranx equula*, (sp. no. 11); lizard fish (sp. no. 7); big-eye; red snapper (sp. no. 6); red-mullet (sp. no. 2); etc.

In order to compare the similarities in species composi-

Table III. Estimated demersal resources of the South China Sea

Region	Area km ²	Density			Standing stock (,000 tons)
		cases/haul	cases/ha	kg/ha	
R3	131,000	16.3	1.5	39	511
R4	217,000	17.3	1.5	39	846
R5	202,000	17.8	1.6	42	840
R6	332,000	21.3	1.9	49	1,640
R7	245,000	26.2	2.3	60	1,465
R8	378,000	24.9	2.2	57	2,162
R9	249,000	31.2	2.8	73	1,813
Total	1,754,000				9,227

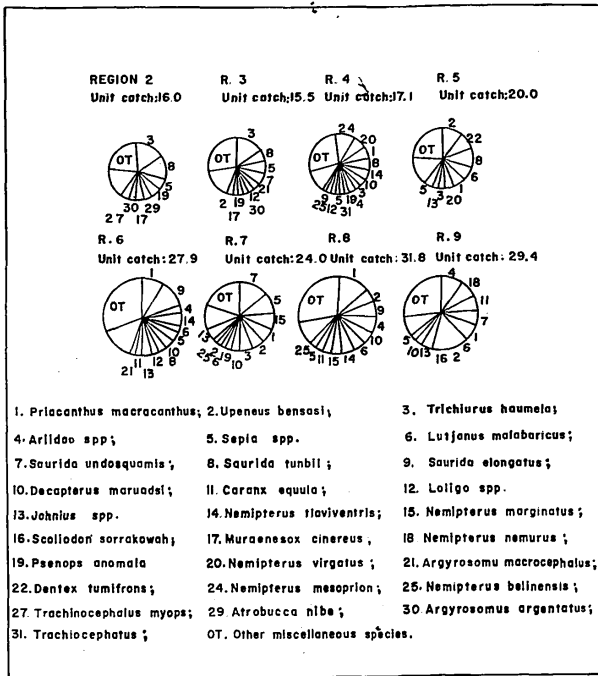

Fig. 4 Values of unit catch and species composition of eight different regions.
 *Unit Catch = cases/haul 1 case = 26 kg.

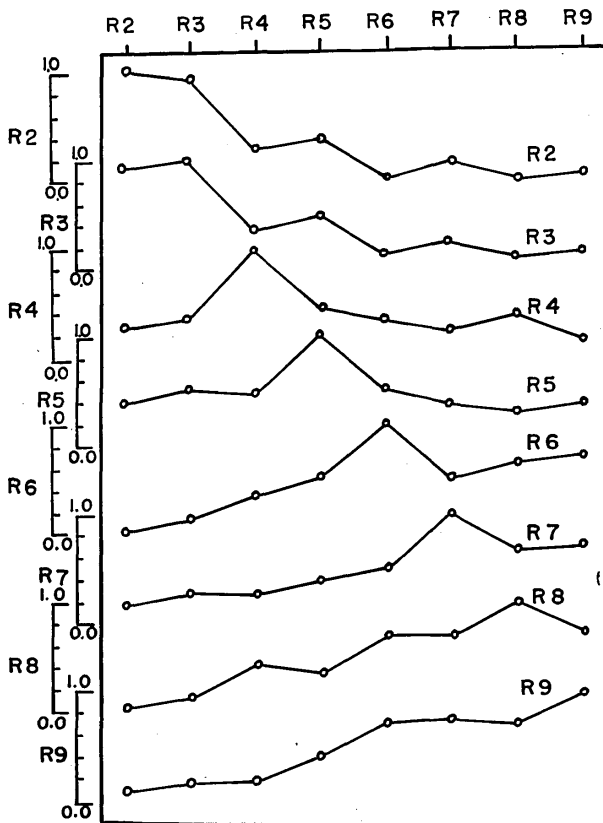

Fig. 5 Series of rank correlation coefficients obtained by the catches from eight different localities during 1970-1971.

tions among these different regions, the Spearman's rank correlation coefficients are arranged by regions. The results are shown in figure 5.

These reveal the same curvatural tendency among regions 3, 4, 5 and among regions 6, 7, 8, 9 as well. The same tendency in curvature implies there is great resemblance in species composition among these regions.

Evidently the tendency of region 3 is much different from those of region 6, 7, 8, 9.

Above all, the figure 5 indicates that the species compositions reveal more or less differences among different regions. However, the geologically nearby areas reveal some similarities between them.

As shown in figure 4, none of the regions reveals any significant dominant species in species composition. This evidence indicates that there is a great diversity in species composition in tropical waters.

2.5 The seasonal variations of catch and species composition

2.5.1. The seasonal variation of unit catch of each species

The seasonal change of the species in unit catch are shown in figure 6-a and 6-b.

The cuttle fish (sp. no. 5) reveals an almost identical seasonal fluctuation patterns in all regions: The maximum yield seasons from Oct. to Mar. and minimum in summer time

Common squid (sp. no. 12) abundant in autumn in all regions.

Hair-tail (sp. no. 3) most abundant in north region (region 3) in winter and spring time, in region 7 it is abundant in autumn.

All the other species and the other miscellaneous species show no significant seasonal changes. The total unit catches also show no significant seasonal changes.

2.5.2 The seasonal variation of species composition

In order to clarify the seasonal change of species composition the Spearman's rank correlation coefficient are arranged by successive seasons in each region, as shown in figure 7.

The curves between A and B seasons and between C and D seasons in each region show same resemblance tendency, but between A, B and C, D seasons they show a little difference. Therefore, there are a few seasonal change in species composition in each region.

3. SUMMARY AND DISCUSSION

The general bottom sediments of the areas are as follows: Taiwan Strait: sand, with rocks around Penghu islands.

South of Hong Kong: mud, with rocks.

Gulf of Tonking: mud

South Vietnam coast: sand, with rocks on the narrow self off Vietnam.

Gulf of Thailand: mud

Between South Malay Peninsula and Borneo: mud, with rocks around Natuna islands.

All of these areas, except the inner part of the Gulf of Thailand and the Gulf of Tonking, have been operated by Taiwan paired trawlers. The workable trawling areas evidently are those of sandy and muddy areas.

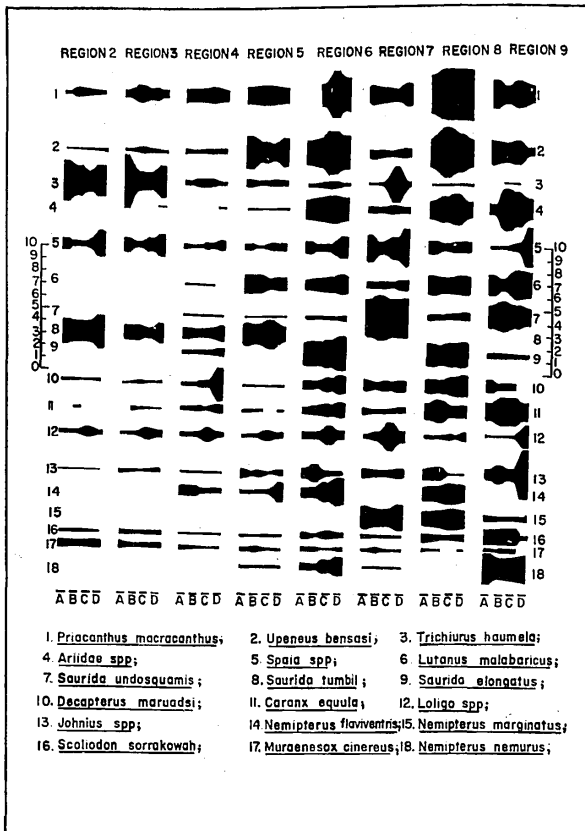

Fig. 6a The seasonal changes of unit catch of each species.
*A: Jan.-Mar. B: Apr.-Jun. C: Jul.-Sep. D: Oct.-Dec.

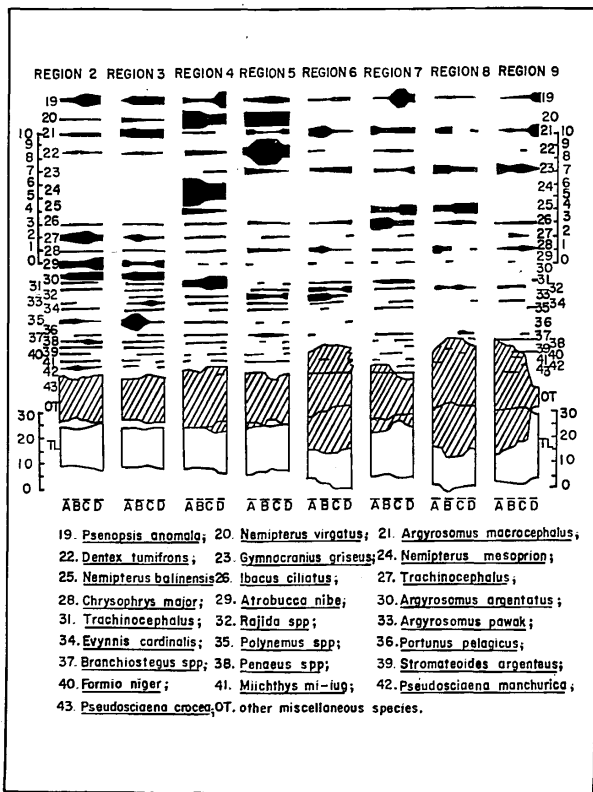

Fig. 6b The seasonal changes of unit catch of each species. (continued)
*A: Jan.-Mar. B: Apr.-Jun. C: Jul.-Sep. D: Oct.-Dec.

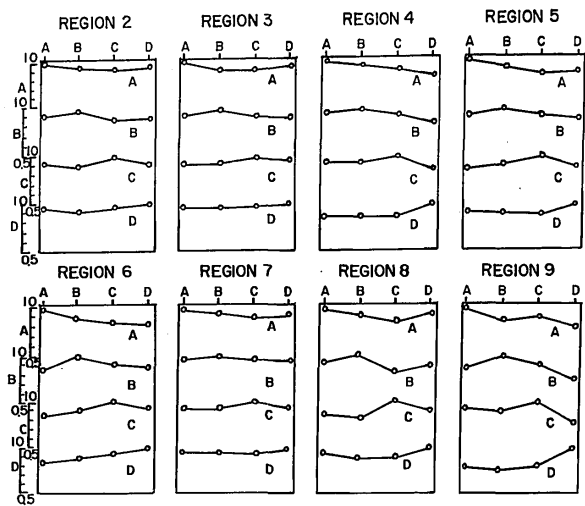

Fig. 7 Series of rank correlation coefficients obtained from four successive seasons.

The species compositions reveal more or less differences among different regions. However, the geographically nearby areas reveal some similarities among them. They also reveal a great diversity of species without any being really dominant and a little seasonal change in species composition in each region. Most presently used population dynamics models, and management practices, were typically developed for individual temperate water species, often long lived. So attention should be focussed on preparing modes on a multi-species or community basis.

Reference

Emery, K. O., 1968. Relict sediments on continental shelves of world. The Amer. Assoc. of Petroleum Geol. Bulletin, 52 (3): 445-464.
Emery, K. O., 1969. Distribution pattern of sediments on the continental shelves of western Indonesia. Technical Bulletin ECAFE, 2:77-82.
Gulland, J. A., The Fish Resources of the Ocean. Fishing News (Books) Ltd., England. 255 p.
Niino, H., and K.O. Emery, 1961. Sediments of shallow portions of East China Sea and South China Sea. Geol. Soc. of American Bulletin, 72: 731-762.
Shindo, S., 1957. Seasonal and annual successions of the Demersal fish communities, observed from the catch of Japanese otter trawl in the East China and Yellow Seas, during from 1947 to 1954. Bulletin of the Seikai Reg. Fish. Res. Lab., 11: 90-16
Williamson, G. R., 1970. Hydrography and weather of the Hongkong fishing ground. Hong Kong Fish. Bulletin, 1: 43-49

Research on Demersal Fishes on the Continental Slope
in the Northern Part of the South China Sea
The cruise result of R/V KAIYO-MARU

by
Tsuneo Aoyama

Seikai Regional Fisheries Research Laboratory
Nagasaki, Japan

1. INTRODUCTION

During the period from May 16 through June 2, 1971, the research cruise for the trawl fishing ground was carried out by R/V Kaiyo-maru (2539 GT) of the Japanese Fisheries Agency in the northern area of the South China Sea between the margin of mainland China continental shelf and continental slope. Experimental trawl fishing operation was done 33 times, and three oceanographic observation lines vertical to the coastal line. Though this cruise was done rather on a small scale, the result might have some valuable suggestions for the future operations of trawling, since the trawl operations in such area as continental slope has been scarce.

The areas A, B and C in the East China Sea were included in this research cruise for two purposes: (1) to obtain some idea of the difference in stock assessment between the south China Sea and the East China Sea and (2) to compare the fishing efficiency of Japanese commercial trawlers.

The sea depth at the stations and number of hauls by area are summarized briefly as follows:

Area	Sea depth	Number of hauls
East China Sea	A 105-118	3
	B 53-76	2
	C 94	2 Total 7
South China Sea	D 87-158	8
	320-328	2
	695-860	2 Total 12
	E 120-158	5
	170-240	2 Total 7
	F 98-127	5
	165-186	2 Total 7

2. RESULTS

1) In the South China Sea, the amount of dissolved oxygen was less than 3.5 ml/l at the depth between 100 and 150 metres and less than 3.0 ml/l at the depth of more than 300 metres. This suggests that there would be less expectation for the large latent fish resources in the depth greater than 300 metres were composed of abyssal fish species for the most part, indicating the

similar results at the continental slope in the East China Sea.

2) Topographical survey by echo sounder indicates that in the areas D and E the continental slope is fairly weak in gradient and forms two or three steps of deep sea terraces. The trawl fishery would be suitable geographically at the flat plane portion, but not possible at the shoulder part of terrace where it is fairly rocky.

In the area F, the topographic survey showed rather steep gradient of the slope.

3) Abundance of the fish was best at the shoulder part of the continental shelf.

4) The catches of this cruise was comprised of larger individuals than those in the East China Sea. The fish were classified and totaled up to 170 species. The main fishing results by area are:

Area D fairly good catch with large sized porgy,* Isaki, rudderfish, and sea bass in the water shallower than 200 metres. On the contrary, very poor fishing was noted in the deeper waters with small amount of abyssal fish species.

Area E poor fishing with small amount of Japanese threadfin bream, rudderfish, big eye snapper and sea bass.

Area F Poor fishing with large sized porgy, hairtail, big eye snapper, Nagasaki snapper and lizard fish.

5) The productivity of the sea area deeper than 350 metres seems to be poor, for the following reasons: 1) the current is not distinguished, 2) there is no strong upwelling, 3) vertical mixing in winter is weak, 4) the thermocline is developed well in general and 5) therefore, the dissolved oxygen is very little in content. The catch in the area were abyssal fishes that seem to be not valuable commercially, only.

In the area of 200 - 350 metres in depth, we caught some large size commercially important fishes, although the amount were not large. As many traces of fishes were observed on the echosounder, it was supposed that there

*porgy	<i>Chrysophrys major</i>
isaki	<i>Parapristipoma</i> spp.
rudderfish	<i>Seriola</i> sp.
sea bass	many spp.
Japanese threadfin bream	<i>Nemipterus</i> sp.
big eye snapper	<i>Priacanthus</i> sp.
hairtail	<i>Trichiurus lepturus</i>
red snapper	<i>Lutianus</i> spp.
Nagasaki snapper	<i>Pristipomoides</i> sp
lizard fish	<i>Saurida</i> spp

were considerably large amount of small fishes which might have escaped through mesh of the net (as the stretched mesh size was 90 mm).

Large sized valuable fishes were caught considerably at the area situated near the edge of the continental shelf, the depth of which was shallower than 200 metres. Especially good catch was encountered at Area D.

The catch per 30 minutes trawling are shown as under :

Area	No. of hauls	Catch per 30 min. haul in ton.
East China Sea	A	3
	B	2
	C	2
	Total	7
South China Sea	D (deep)	9
	D (shallow)	4
	E (d)	6
	E (s)	1
	F (s)	5
	Sub total (d)	20
	" (s)	5
Total	25	

The fishing efficiency of the R/V Kaiyo-maru was rather low compared to the Japanese commercial pair trawlers, as shown below: the value of catch per 80 minutes' trawling which is the standard trawling duration of pair trawlers.

Area	Commercial pair trawler				Kaiyo-maru	
	May 1970		June 1970		H	CPH
	H	CPH	H	CPH	H	CPH
A	1156	0.30	463	0.30	3	0.26
B	4156	0.32	1853	0.44	2	0.25
C	16	0.37	7	0.32	2	0.15

H, number of hauls; CPH, catch per 80 minutes' trawling.

THE FISHERIES OCEANOGRAPHY

SEAFDEC/SCS.73: S-4

Fishing Condition and its Oceanographic Interpretation in Bottom Long Line Fishing Grounds

by
Otohiko Suzuki

Marine Fisheries Research Department
Southeast Asian Fisheries Development Center

Abstract

During the experimental bottom long line fishing conducted in June and September, 1972, near the Gulf of Thailand and off Kuching, Sarawak respectively, simultaneous oceanographic surveys were also carried out. The analysis of the data suggested possible relation between oceanographic and fishing conditions. Throughout the two trips it was a common feature that good catches were often obtained near the boundary between the nearshore warm water and the deeper cold water.

Through oceanographical consideration of the data obtained, the following conclusion was deduced. There is a possibility that good fishing grounds are located along the canyon off Kuching throughout all seasons. However, their locations may be altered with the change of oceanographic conditions. In the area off the Gulf of Thailand, good fishing grounds may be formed only in certain specific seasons.

INTRODUCTION

Studies on the feasibility of bottom long lining in the South China Sea were conducted by the research vessels CHANGI in June and September, 1972. One of the two survey cruises was made near the Gulf of Thailand during

17-25 June, and the other off Kuching, Sarawak between 16 and 27 September. Systematic surveys on oceanographic condition were also carried out simultaneously with the experimental bottom long line fishing.

The purpose of these studies was to investigate the existence of possible relationship between oceanographic and fishing conditions.

SURVEYS

During the June trip, the experimental bottom long linings were made at six different locations within the area enclosed by 6°20'N and 8°15'N in latitude, and 102°20'E and 103°45'E in longitude. Except for one operation at the final location, two operations using different types of long line were made repeatedly at each location. The number of units used in each operation ranged from 14 to 21. Twenty oceanographic stations were arranged at almost regular intervals to cover this area, while six other stations outside the area were arranged at intervals of about 30 nautical miles along the east coast of the Malay Peninsula. At each station serial and BT observations were made.

During the trip in September, bottom long line opera-

tions were made at six different locations arranged almost along a submarine canyon, off Kuching. In most cases one operation was made at each location, but at some locations two operations were made using the same type of long line. The number of units used in each time was in the range of 15–50. Twenty-six serial and BT observation stations, together with some additional BT stations, were arranged to cover the whole area bounded by $3^{\circ}30'N$ and $2^{\circ}10'N$, and $110^{\circ}50'E$ and $109^{\circ}45'E$.

RESULTS

Area Off the Gulf of Thailand

The bottom configuration around this area is very irregular and shows some interesting features (Fig. 1). The sill of the Gulf of Thailand runs along a line connecting the border of Thailand and Malaysia with the tip of Cape Ca Mau. While it is about 55–60 m. deep the two troughs near the sill, one approaching from the Gulf of Thailand, and the other from the open ocean, are deeper than 70 m. A wide bank off Cape Ca Mau extends towards the bay head along the east coast of the Gulf. While from the opposite side, a submarine ridge shallower than 50 m. projecting from the border of Thailand and Malaysia to the midpoint of the sill towards Cape Ca Mau.

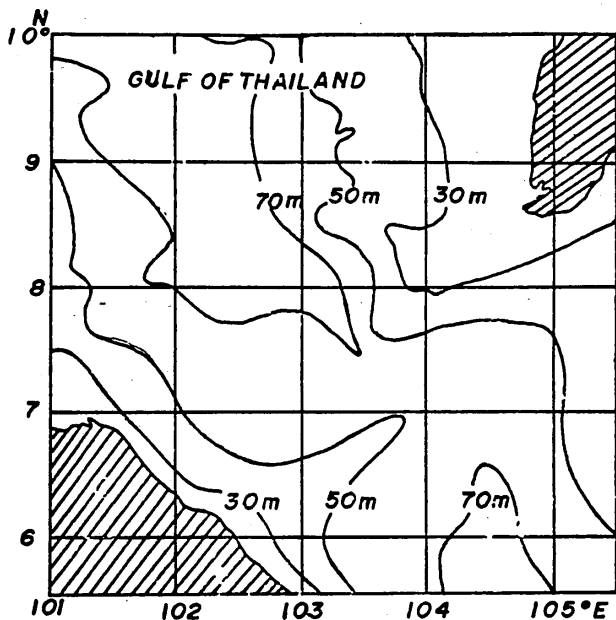

Fig. 1 Bottom configuration near the Gulf of Thailand. Depths in meters. (After Robinson, 1963).

Using the data collected, the distribution pattern of temperature was analysed three-dimensionally. The result showed that during the period there was an intense intrusion of cold water mass from the offshore area into the warm water area in the Gulf. The intrusion of the offshore water could be clearly seen even from the distribution pattern of surface temperature (Fig. 2). The most conspicuous feature of intrusion, however, was observed in deeper layers as illustrated in Fig. 3. The cold water mass lower than $25^{\circ}C$ creeps up along the trough

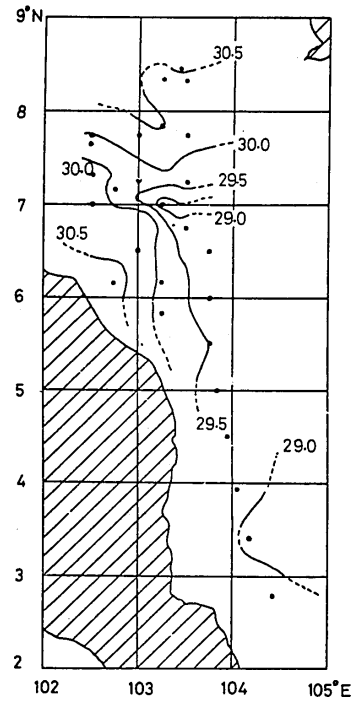

Fig. 2 Distribution pattern of surface temperature near the Gulf of Thailand, June, 1972. Temperature in $^{\circ}C$.

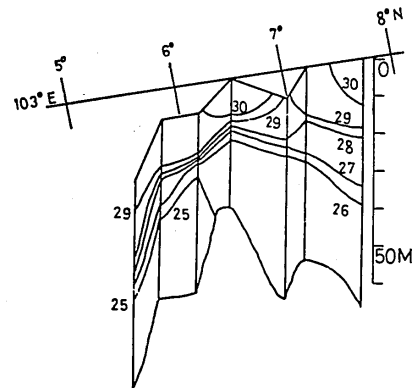

Fig. 3 Vertical section of temperature along the course of intrusion of offshore water.

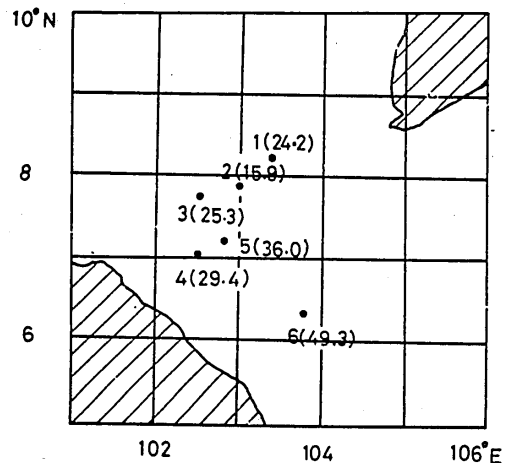

Fig. 4 Location chart of experimental bottom long linings off the Gulf of Thailand.

from the open ocean and reaches to the top of the submarine ridge projecting from the Malay Peninsula. The advance of this water mass seems to be interrupted by the ridge. The water mass higher than 25°C crosses over the ridge and enters into the Gulf through the other trough.

Fig. 4 shows the location chart of bottom long line fishing grounds, and the catch in kg. per 10 units of gear. As seen in the figure a good catch was obtained at the final fishing ground which was located near the top of the ridge where the isothermal surface of 25°C came to meet the bottom. While the other grounds were inside the Gulf and in most of these grounds the temperature at the bottom was 27°C.

Area Off Kuching, Sarawak

The bottom configuration in this area is characterized by a submarine canyon whose head originates near the mouth of Lupar River, as shown in Fig. 5. This canyon can clearly be traced to a depth of about 80 m. It is about 20 km. in width and the depth exceeds 100 m. in the deepest portion. The canyon extends almost linearly from the head towards the northwest and then turns towards the north at 2°30'N, 110°15'E. On both sides of the canyon, the bottom slopes gently towards the offshore region.

The distribution of water masses is not so complicated in this area (Fig. 6). On both sides of the canyon, water is almost spatially homogeneous and is about 29°C. The water mass below 28°C is seen only along the canyon. Cod water below 23°C is observed near the mouth of the canyon while the bottom temperature at the bend is below 25°C.

In Fig. 7 the locations of fishing grounds are shown together with the catch obtained. The first four fishing

grounds were located between the mouth and the bend of the canyon, and the last two grounds were between the bend and the head. Good catches were obtained at the last two locations and these fishing grounds were close to the east upper edge of the slope of the canyon where the isothermal surface of 26.5°C came to meet the bottom. The other fishing grounds were inside the water mass whose temperature was below 25°C.

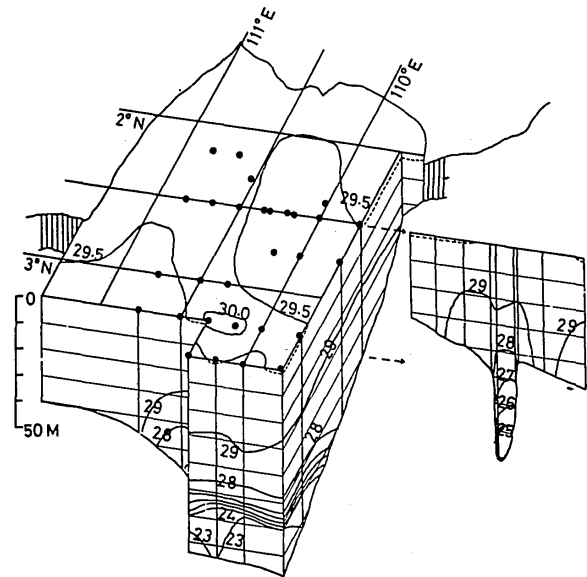

Fig. 6 Composite surface and vertical sections of temperature off Kuching, September, 1972. Temperature in °C.

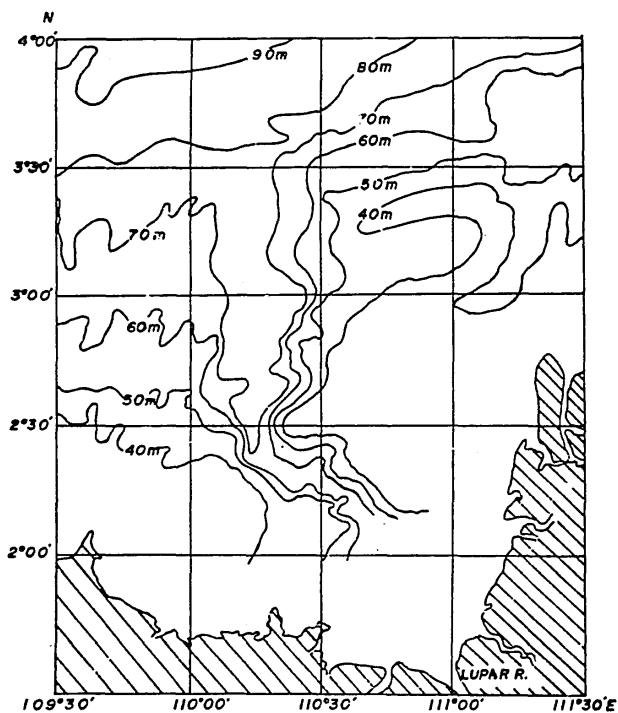

Fig. 5 Bottom configuration off Kuching, Sarawak. Depths in meters. (Source: original chart prepared by Faculty of Fish., Hokkaido Univ.)

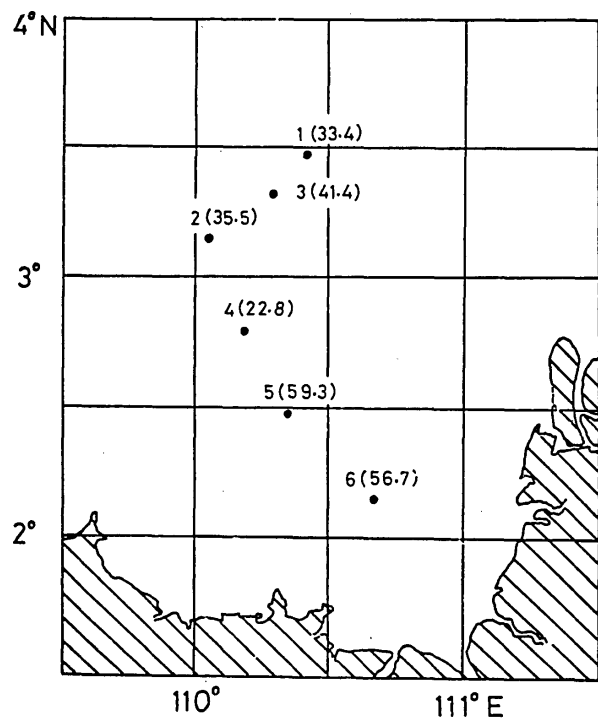

Fig. 7 Location chart of experimental bottom long linings off Kuching.

DISCUSSION

The common feature of the June and September trips is that good catches were obtained near the boundary between the nearshore warm water and the cold water from deeper layers. It is presumed that cold water could be observed at other places such as the canyon off Kuching in which the boundary of cold and warm water masses could be formed. However, such boundary surfaces are considered as unstable. Near the Gulf of Thailand, the intense intrusion of deep-layer water, as observed in June, 1972, is considered to occur only in certain specific seasons.

SEAFDEC/SCS.73: S-6

Behaviour of the Warm-Water Mass
Along the East Coast of the Malay Peninsula
by
Otohiko Suzuki and Kok-Kuang Hooi
Marine Fisheries Research Department
Southeast Asian Fisheries Development Center

Abstract

A preliminary study was made on oceanographic conditions in the South China Sea, using the data collected over two monsoon seasons. In the northeast monsoon and the subsequent stagnant season, a narrow belt-like water mass of high temperature and low salinity was observed along the east coast of the Malay Peninsula. While in the southwest monsoon season, the existence of this water mass was not clear.

The presence of this narrow belt of water mass suggest the existence of a southward-flowing current which may play a role in transporting the water from the Gulf of Thailand to the coastal area of the Peninsula.

INTRODUCTION

Along the east coast of the Malay Peninsula a narrow belt-like water mass of high temperature and low salinity, extending from the Gulf of Thailand to the vicinity of Singapore, was observed by the research vessel CHANGI in April, 1971. On the other hand, during a joint trawl survey by Thailand, Malaysia and Germany conducted in this area between March and April, 1967, a southward-flowing current of about one knot was observed in the nearshore area. The above two facts seem to suggest that the southward-flowing current in this season plays a role in transporting the water from the Gulf of Thailand to the coastal area of the Peninsula.

Using the data from CHANGI together with some other data, analysis was made to clarify the behaviour of this water mass in more detail. When considering the geostrophic balance of water masses, the above belt of water is concluded to flow in a southerly direction. The results are described here.

CONCLUSION

There is a possibility that good fishing grounds along the canyon off Kuching can be formed throughout all seasons. However, the locations of good fishing grounds may be changed according to the change in oceanographic conditions. Near the Gulf of Thailand, good fishing grounds may be formed only in some seasons.

Reference

- Robinson, M.K., 1963. physical Oceanography in the Gulf of Thailand.
Ecology of the Gulf of Thailand and the South China Sea. A report on the results of the Naga Expedition, 1959-1961: 34-50.

OBSERVATIONS

Between October, 1970 and June, 1971, four research trips were made by CHANGI to the area off the east coast of the Malay Peninsula. These are as follows:

Period	Number of Stations
17 - 22, Oct., 1970	6
17 - 23, Nov., 1970	7
13 - 26, Apr., 1971	21
31 May - 12 June 1971	16

The first two cruises were carried out during the northeast monsoon season, and observation stations were arranged at irregular intervals of 40 to 100 nautical miles along the coast. The third cruise was made in the spring intermonsoon season. The stations were arranged to form meshes at relatively regular intervals of about 60 nautical miles off the east coast of the Peninsula and this cruise covered the widest area among the four cruises. The fourth cruise was carried out at the beginning of the southwest monsoon, and stations were arranged at regular intervals of 60 nautical miles.

At each station serial observation was made, and in addition BT observation was made during the last two trips.

OCEANOGRAPHIC CONDITION OFF EAST COAST OF MALAY PENINSULA

Analysis of the data was made three-dimensionally to get synoptic information. Fig. 1 shows the composite surface and vertical sections of temperature in the spring intermonsoon season, 1971. The interesting feature is a narrow belt of warm water mass along the east coast of

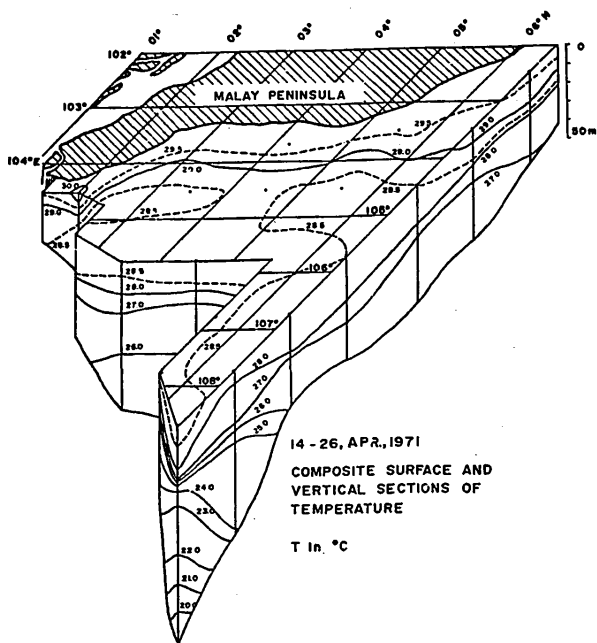

Fig. 1 Composite surface and vertical sections of temperature. April, 1971.

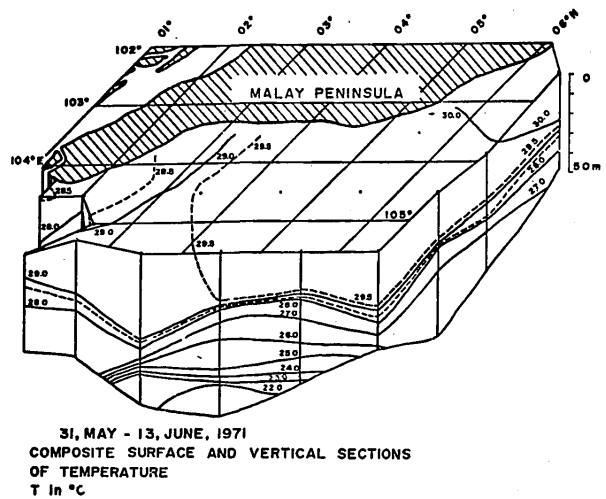

Fig. 3 Composite surface and vertical sections of temperature. May to June, 1971.

the Malay Peninsula, which is over 29°C in temperature. This was between 10 and 20 m. in depth and extended from the mouth of the Gulf of Thailand to the vicinity of Singapore. This water mass was low in salinity, and this fact will be discussed later in more detail.

The behaviour of this coastal water during the previous northeast monsoon is suggested in Fig. 2. The figure shows the vertical sections of temperature during October and November, 1970. As seen in the figure, there are fewer stations, and they were not arranged to form meshes. Consequently, we cannot clearly map out the pattern of the coastal water. However, water of high temperature is shown at stations nearer to the coastline. This water of high temperature was also low in salinity.

The composite surface and vertical sections of temperature in the early stages of the southwest monsoon season are shown in Fig. 3. The locations of stations along the coastline were almost identical to those of the April expedition. The water layers are thermally well stratified, as seen in the figure, and the surface temperature increases with increasing latitude. It should be noted in particular that the narrow belt of warm water along the coastline which was seen in the northeast monsoon and its subsequent stagnant seasons is not present in the figure. Although most of the shallow layers are covered by water over 29°C , this water mass seems to be different from that which covered the coastal area in the two previous seasons, since the salinity of this water mass was considerably higher.

Our attention has been focussed on the coastal water of high temperature and low salinity, which is likely to appear only in the northeast monsoon and its subsequent stagnant seasons. The fact that this water mass extended from the Gulf of Thailand suggests that it might have originated from the Gulf.

Before discussing this point, the temperature and salinity characteristics of the water in the southern part of the South China Sea and that in the Gulf of Thailand must first be considered.

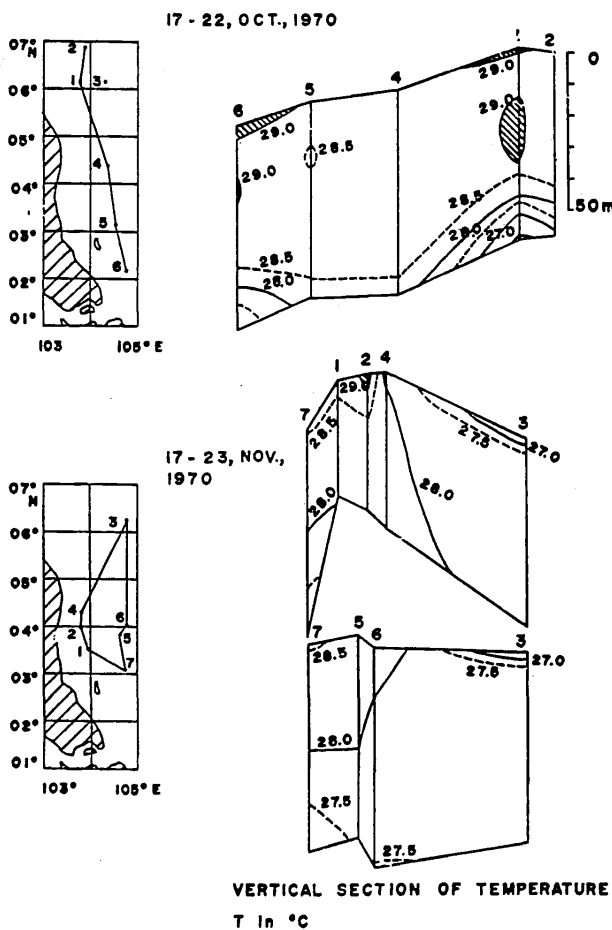

Fig. 2 Vertical sections of temperature. October and November, 1970.

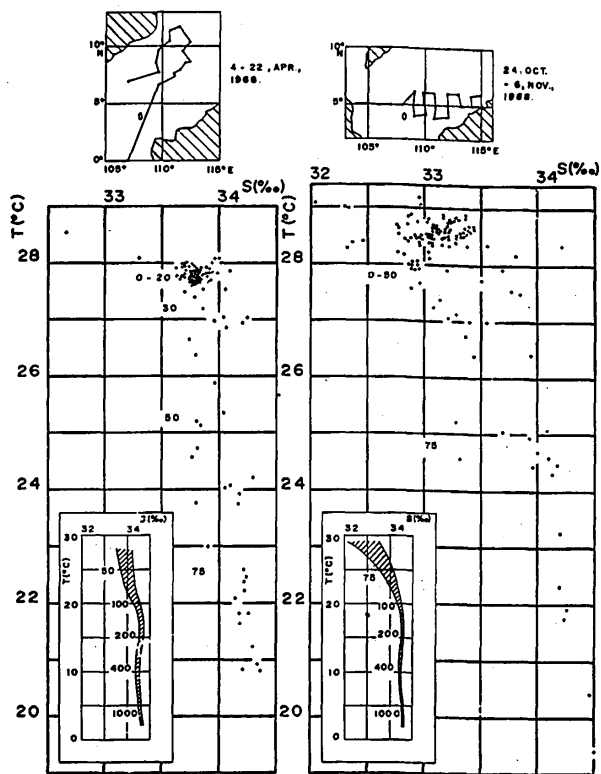

Fig. 4 T-S diagrams in southern part of South China Sea, April and October to November, 1968.

T-S CHARACTERISTICS OF WARM-WATER MASS AND THOSE IN NEIGHBOURING WATERS

Using the CSK data collected in April and November, 1968, the temperature-salinity diagrams of the southern part of the South China Sea were constructed as illustrate in Fig. 4. In layers shallower than 100 m. in depth, some signs of seasonal changes are noticeable. During the northeast monsoon the salinities of the upper layers were rather widely distributed, as seen at the upper part of the T-S diagram for November, 1968. This is probably due to the locations of the observation stations, which stretched from the Malay Peninsula to waters off Borneo. In fact, those plots below 33 ‰ in salinity are for the stations near the two coasts. Taking this fact into consideration, we may conclude that during the northeast monsoon and its subsequent stagnant season, the off-shore water in the South China Sea seldom exceeds 29°C and is seldom below 33 ‰.

Fig. 5 shows the T-S diagrams in the bay head area of the Gulf of Thailand around April, 1967. The data for this figure were also obtained from CSK. It is seen from the two T-S diagrams that the salinity in the bay head area was about 32 ‰ or less.

On the results of the NAGA Expedition, Robinson (1963) reported that between April and May, 1960 the surface temperature throughout the Gulf of Thailand exceeded 30°C while the surface salinity and that of the shallower parts of the Gulf were below 33 ‰.

Fig. 6 shows the T-S diagrams, plotted from the CHANGI data collected in April, 1971. In this figure are

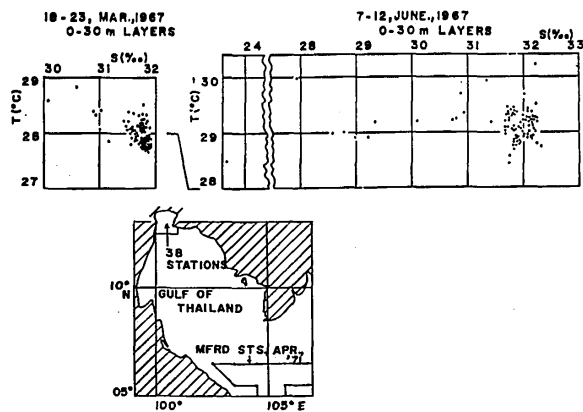

Fig. 5 T-S diagrams in bay head of Gulf of Thailand, March and June, 1967.

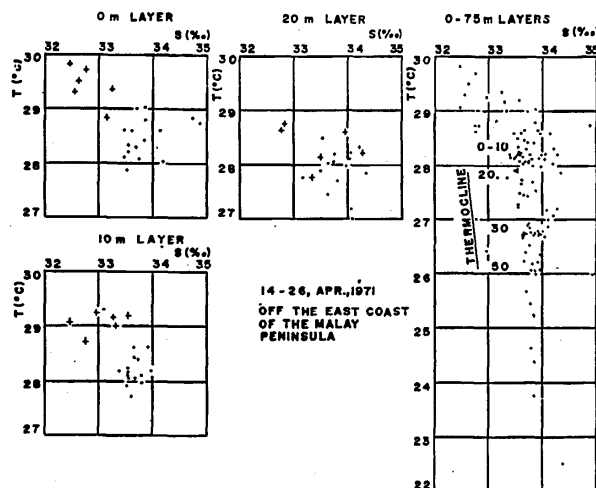

Fig. 6 T-S diagrams off east coast of Malay Peninsula, April, 1971.

shown the T-S plots for 0, 10 and 20 m. layers separately as well as plots for 0 to 75 m. together. In the T-S diagrams for 0 and 10 m. there are clearly two distinct groups of plots. The plots with cross are from stations within the narrow belt of warm water. At 20 m. depth, however, it is hard to distinguish clearly the water masses.

From the above findings, it could be inferred that during the northeast monsoon and its subsequent stagnant period, the warm water of low salinity of the Gulf of Thailand flows out as a narrow belt along the east coast of the Malay Peninsula.

DISCUSSION

In Fig. 1 the warm water mass is almost parallel to the coastline and is between 10 to 20 m. in depth. In the area to the north of the Malay Peninsula, we estimate the velocity of this water mass by using an idealized model and some simplification of our data. In this model the isothermal surface of 29°C is assumed to be a boundary which separates the coastal and offshore waters.

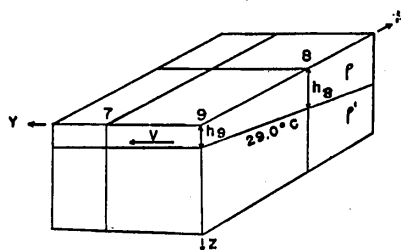

Fig. 7 Ideally simple model of two homogenous layers.

Imagine that the sea consists of two homogeneous layers, and the lower layer is at rest. The current v in the upper layer is assumed to be parallel to the y -axis of the coordinate system in Fig. 7. Then, from the consideration of the geostrophic balance, we can get the following relation:

$$f \cdot v = (1 - \rho/\rho') g \frac{dh}{dx} \quad (1)$$

where f is the Coriolis' factor and is expressed as $2 \omega \sin \varphi$. h is the thickness of the upper layer, and ρ and ρ' are the densities of the upper and lower layers respectively. On substitution of

$$\begin{aligned} \rho &= 1.0207 \text{ g.cm}^{-3}, & \rho' &= 1.0218 \text{ g.cm}^{-3}, \\ \Delta h &= 8 \text{ m}, \Delta x &= 110 \text{ km}, & g &= 980 \text{ cm.sec}^{-2}, \\ \omega &= 7.292 \times 10^{-5} \text{ rad.sec}^{-1}, & \varphi &= 6^\circ 30' \text{ N}, \end{aligned}$$

into the above equation and calculating, we have

$$v = 47.6 \text{ cm. sec}^{-1}$$

SEAFDEC/SCS.73: S-13

Preliminary Report on the Distribution of Chaetognaths in the Southern Part of the South China Sea

L.C. Lim

Marine Fisheries Research Department
Southeast Asian Fisheries Development Center
Changi Point, Singapore

Abstract

This paper reports the distribution of chaetognaths in the southern part of the South China Sea, based on the plankton samples collected by the research vessel CHANGI from April 1970 to April 1972.

The chaetognath specimens collected in April, 1972 were identified. Altogether 22 species belonging to 5 genera were discerned. *Sagitta enflata* was the dominant species and was widely distributed in the areas surveyed. While the common species in the neritic waters are *S. bedfordii*, *S. bedoti*, and *S. oceanica*, the common species in the oceanic province are *Krohmitta pacifica*, *K. subtilis*, *Pterosagitta draco*, *S. bipunctata*, *S. hexaptera*, *S. lyra*, *S. minima*, *S. pacifica* and *S. regularis*. *S. enflata* and *S. ferox* are common in both neritic and oceanic provinces.

In other words, there may be a southward-flowing current of about one knot along the east coast of the Malay Peninsula.

As mentioned before, this southward-flowing current was actually observed during a joint survey by Thailand, Malaysia and Germany (Anon., 1967). observation agrees with our results.

CONCLUSION

A narrow belt of southward-flowing current is considered to appear along the east coast of the Malay Peninsula during the northeast monsoon and its subsequent stagnant season. By this current the water of the Gulf of Thailand seems to be transported to the area off the east coast of the Peninsula.

References

- Robinson, M. K. 1963. Physical oceanography in the Gulf of Thailand. Ecology of the Gulf of Thailand and the South China Sea, A report on the results of the Naga Expedition, 1959-1961: 34-50.
- Anonymous 1967. Results of the joint Thai-Malaysian-German trawling survey off the east coast of the Malay Peninsula, 1967. Marine Fisheries Laboratory, Department of Fisheries, Ministry of Agriculture and Cooperatives, Thailand and Fisheries Research Institute, Fisheries Division, Ministry of Agriculture and Cooperatives, Malaysia. 18 p. 1967.

1. INTRODUCTION

Chaetognatha, a group of permanently planktonic invertebrates, is one of the dominant groups of zooplankton in the South China Sea. It is an important food item of some juvenile and plankton-feeding fishes. Certain species of Chaetognaths, such as *Sagitta setosa* and *S. elegans*, were reported to be associated with a more or less specific hydrographical environment, and thus are useful indicators of the movement of water masses (Fraser, 1952). Studies on this group of zooplankton is therefore a matter of particular importance.

In the Southeast Asian region studies on the Chaetognaths have been carried out mainly in the Gulf of Thailand (Alvarino, 1963, 1967), the waters off east coast of Vietnam (Alvarino, 1967; Hamon, 1956; Serene, 1937) and near Penang Island (Pathansali, 1968). Wickstead (1961) reported briefly on 10 species belonging to 3 genera in the Indo-West Pacific waters. No other data has hitherto been published on Chaetognatha in the southern part of the South China Sea.

Since 1970, oceanographic survey cruises have been carried out by the research vessel CHANGI of the Marine Fisheries Research Department, Southeast Asian Fisheries Development Center (SEAFDEC), in the southern part of the South China Sea, from 1°30'N to 10°20'N. This paper is a preliminary report on the results of analysis on the distribution of Chaetognatha, based on the samples collected from April 1970 to April 1972. For the identification and occurrence of species, only the samples collected in April 1972 are dealt with.

2. MATERIALS AND METHODS

Plankton samples were collected by two vertical hauling at each station. Vertical hauling was made from 3 to 5 m above the sea floor or from a maximal depth of 150 m to the surface. The plankton net used was the North Pacific Standard Net with mesh size of 0.33 mm. The net was fitted with a flow-meter at the central part of the mouth to measure the total volume of water filtered

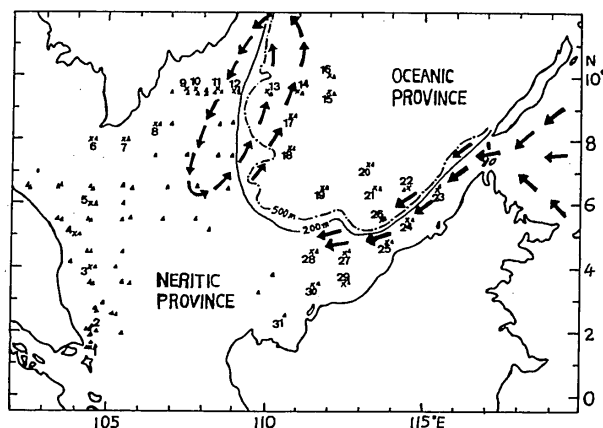

Fig. 1 Locations of sampling stations of CHANGI in 1970-1972.

X = sampling stations of the 1972 April cruise;
 Δ = sampling stations of other cruises; the arrows indicate water movement as illustrated in the surface current chart for April by Naga Report (Wyrтки, 1961).

through the net.

Plankton samples collected were preserved in 5% neutral formalin on board. In the laboratory all Chaetognaths were sorted from each sample and their individual numbers per cubic meter of water estimated.

The location of sampling stations are shown in Fig. 1. The surveyed areas are divided into 2 provinces, the neritic province (continental shelf area), and the oceanic province (area where the depth exceeds 200 m)

3. RESULTS

3.1 Species composition

A total of 22 species belonging to 5 genera were recorded. The list of species is shown below:

- Genus *Eukrohnia* Ritter-Zahony
 - E. hamata* (Möbius) 1875
- Genus *Krohnitta* Ritter-Zahony
 - K. pacifica* (Aida) 1897
 - K. subtilis* (Grassi) 1881
- Genus *Pterosagitta* Costa
 - P. draco* Krohn 1853
- Genus *Sagitta* Quoy and Gaimard
 - S. bedfordii* Doncaster 1903
 - S. bedoti* Beraneck, 1895
 - S. bipunctata* Quoy & Gaimard 1827
 - S. decipiens* Fowler 1903
 - S. enflata* Grassi 1881
 - S. ferox* Doncaster 1903
 - S. hexaptera* d'orbigny 1834
 - S. Iyra* Krohn 1853
 - S. minima* Grassi 1881
 - S. neglecta* Aida 1897
 - S. oecania* Grey 1930
 - S. pacifica* Tokioka 1940
 - S. pulchra* Doncaster 1903
 - S. regularis* Aida 1897
 - S. robusta* Doncaster 1903
 - S. septata* Doncaster 1903
 - S. zetesios* Fowler 1905
- Genus *Spadella* Langerhans
 - Sp. cephaloptera* Grassi 1883

3.2 Occurrence

The occurrence of various species of Chaetognatha collected in April, 1972 is shown in Table I.

Alvarino (1967) recorded three species of the Genus *Eukrohnia* from the Naga collection. In the present collection, only one species of the genus, *E. hamata*, was found at two stations in the oceanic province. The other two species, *E. bathypelagica* Alvarino and *E. fowleri* Ritter-Zahony, were reported by Alvarino (1965) as mesoplanktonic plankton occurring in waters below 700 m.

Both species of the genus *Krohnitta* were found in the southern part of the South China Sea. *K. pacifica* appeared in most stations in the oceanic province and some stations in the neritic regions. It was more common than *K. subtilis*, the distribution of which was restricted to the oceanic province only.

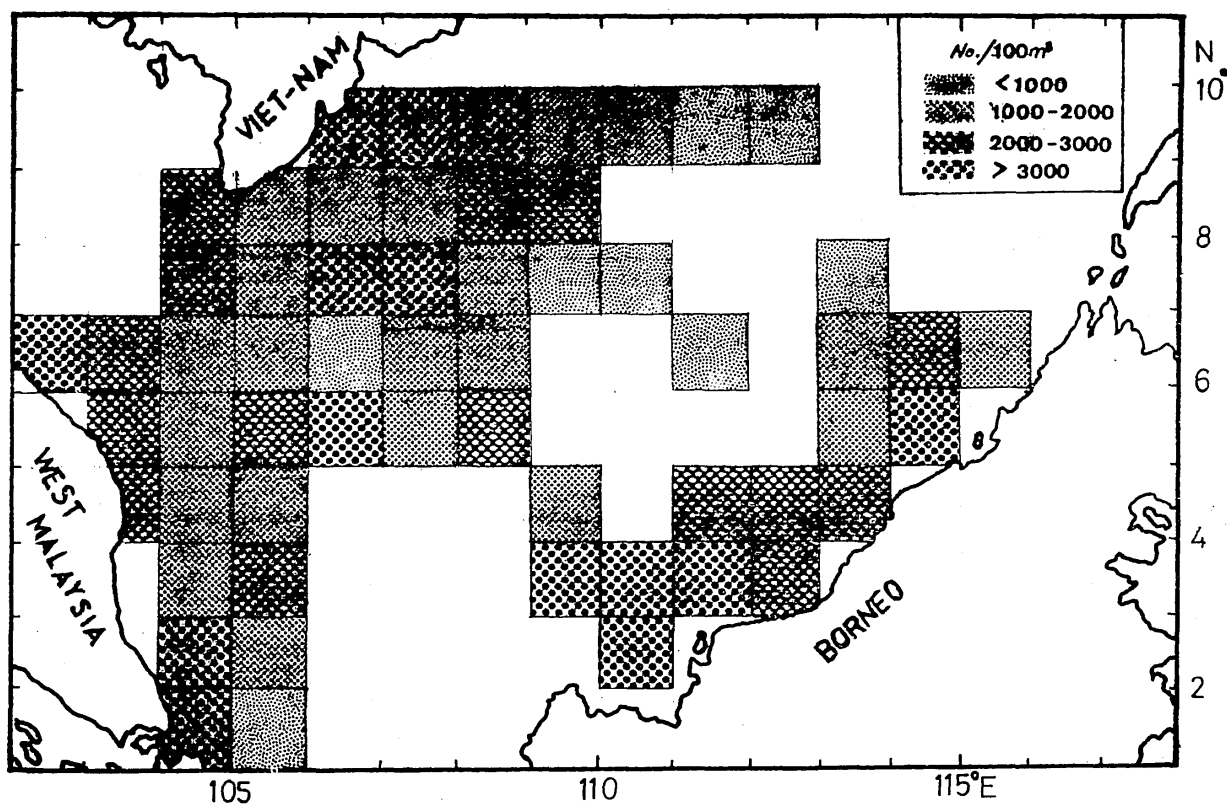

Fig. 2 Quantitative distribution of Chaetognatha in the South China Sea (1970-1972)

3.3 Quantitative distribution

Fig. 2 shows the quantitative distribution of chaetognaths in the southern part of the South China Sea, 1970-72. The abundance of chaetognaths is represented in a block of 1 sq. degree (60 x 60 mile²). When there are more than one station in the same block, only the average values of individual numbers of the respective stations are shown.

The individual numbers of chaetognaths in the southern part of the South China Sea varies from 400 to 13,000

per 100 m³ water. High numbers of chaetognaths were sampled in areas near Singapore, the Gulf of Thailand, off Vietnam, the northwest coast of Borneo and in some offshore areas of the Continental Shelf.

Chaetognatha was abundant in coastal areas but decreased towards offshore waters. This phenomenon is more obvious in the area along 6°30'N and 9°30'N. As shown in Table II, the individual numbers of chaetognaths were highest in near-shore stations and decreased towards the open seas.

Table II. Quantitative distribution of Chaetognatha (No./100m³) in relation to the distance from shore.

Along 6°30'N (June 1971)	Longitude	102°30'E	103°30'E	104°30'E	105°30'E	
	Distance (ml.)	30	30	150	210	
	Number	6,100	1,600	1,590	1,300	
Along 9°30'N (September 1971)	Longitude	106°50'E	107°30'E	108°00'E	108°30'E	109°00'E
	Distance (ml.)	40	80	110	140	170
	Number	13,000	9,700	7,480	3,500	1,220
Along 9°30'N (April 1972)	Longitude	108°00'E	109°00'E	110°00'E	111°00'E	112°00'E
	Distance (ml.)	110	170	230	290	350
	Number	2,550	1,860	1,600	600	590

4. DISCUSSION

The distribution of plankton is dependent on its physiological adaptation to the environment and on the water movement. Thus, any water mass may have, to some extent, its own characteristic plankton.

Different types of water may often be clearly defined by their planktonic communities or at least by certain of their plankton species (Alvarino, 1965). Of the 22 species of chaetognaths collected by CHANGI in April 1972, some species were found to be common in one province but rare or completely absent in another. Such a pattern of distribution indicates that the occurrence of the respective species may be associated with environmental factors. As mentioned above, *K. subtilis* and *S. lyra* were found only in the oceanic province while *S. bedfordii* and *S. oecania* were common in neritic waters. Thus, they can be considered as typical oceanic plankton and neritic plankton respectively. Other species such as *P. draco*, *S. hexaptera*, *S. pacifica* and the less common species of *E. hamata* and *S. decipiens*, found mainly in oceanic waters, may be grouped as oceanic type. Although *P. draco*, *S. hexaptera* and *S. pacifica* were essentially oceanic species, they were also observed in the neritic waters (stations 11, 12 and 23) adjacent to the oceanic province. This may suggest that mixing of oceanic and neritic waters may occur in these areas.

S. minima, a common species in the oceanic province, was found to be more abundant in the neritic waters adjacent to the oceanic province, (stations 11, 12, 23, 25 and 28). Alvarino (1965) regarded it as an oceanic epipelagic species, typical in regions where the mixing of waters occurred. Thus, the presence of *S. minima* in the neritic waters adjacent to the oceanic province further demonstrates that there was mixing of oceanic and neritic waters in the respective areas during the survey.

From the discussion made so far, it may be concluded that *P. draco*, *S. hexaptera*, *S. minima* and *S. pacifica* could be regarded as biological indicators of the presence of oceanic waters in the neritic province.

According to the Naga Report and the surface current chart (Wyrтки, 1961) a belt of oceanic water, originated from Sulu Sea, flows through Balabac strait into the South China Sea. As shown in Fig. 1, sampling stations 23, 25 and 28 of the CHANGI survey cruise in April 1972 were located along this belt. This may explain the presence of some oceanic chaetognaths species in the neritic waters. As for stations 11 and 12, the mixing of oceanic and neritic waters could be due to the circular current movement in the area as illustrated in the current chart of the Naga Report.

The present analysis shows that chaetognaths are abundant in the coastal areas but decrease towards offshore waters. As reported by Shirota et al. (1972), high plankton biomass is mainly confined in the coastal areas of the South China Sea. Since chaetognaths are plankton-feeders, their abundance recorded in inshore waters could be attributed to the high productivity there. On the other hand, their abundant occurrence in certain offshore areas of the continental shelf may be due to the effect of boundary zone or current rip formed in the adjacent

waters of the sampling stations as indicated in the summarized charts of the Naga Report (Wyrтки, 1961).

References

- Alvarino, A. 1963. Chaetognatha, Siphonophorae and Medusae in the Gulf of Siam and the South China Sea. A Report on the Results of the Naga Expedition, 1959–1961. Scripps Institution of Oceanography, S 10—Ref. 63-6: 104–112.
- Alvarino, A. 1965. Chaetognatha. pp 115–194 in Oceanography and Marine Biology, Vol. 3, 421 p. (H. Barnes, ed.) London, George Allen S. Unwin. 3:115–194.
- Alvarino, A. 1967. The Chaetognatha of the Naga Expedition (1959–1961) in the South China Sea and the Gulf of Thailand. Scripps Institution of Oceanography. 197 p.
- Delsman, H. Co., 1939. Preliminary plankton investigations in the Java Sea. *Treubia*, 17:139–181.
- Fraser, J. H., 1952. The Chaetognatha and other Zooplankton of the Scottish Area and their value as Biological Indicators of Hydrographical Conditions. Edinburgh, Her Majesty's Stationery Office. 52 p.
- Hamon, M. 1956. Chaetognathes recueillis dans la Baie de Nhatrang-Cauda (Viet-Nam). *Bull. Mus. Hist. Nat.*, Paris, 28(5):466–473.
- Pathansali, D., 1968. Some observations on the distribution of Chaetognatha west of Penang Island. *Publ. Seto Mar. Biol. Lab.*, XV(5):391–397.
- Serene, R. 1937. Inventaire des invertébrés marins de L'Indochine (Ire. liste). *Inst. Oceanog. Nhatrang*, 30:30.
- Shirota, A., L. C. Lim and M. Chow. 1972. Some oceanographic characteristics of the southern part of the South China Sea. *IPFC Sym. paper*, 72/SYM41:1–11.
- Wickstead, J. H., 1961. A Quantitative and Qualitative Study of Some Indo-West-Pacific Plankton, London, Her Majesty's Stationery OFFICE 200P'
- Wyrтки, K., 1961. Physical Oceanography of Southeast Asian Waters. Naga Report, Vol. 2. Scripps Institution of Oceanography. 195 p.

Some Consideration on the Relationship between Environmental
Factors and the Distribution of Fisheries Resources in the
South China Sea and the Andaman Sea

by
Akihiko Shirota

Marine Fisheries Research Department
Southeast Asian Fisheries Development Center
Changi Point, Singapore

Abstract

This paper discusses the relationship between environmental factors and the distribution of fisheries resources in the South China Sea and the Andaman Sea, based on the oceanographic and fisheries resources data collected by R/V CHANGI from November, 1969 to March, 1973.

The fish catch is related more to the bottom topography than the bottom feature of the sea. Good mean catch (> 200 kg/hr) was obtained in upwelling regions at the steep continental slope in areas off the north and the east coast of the Andaman Sea, and in areas with boundary zone at the flat area along the east coast of Malay Peninsula.

The distribution of fisheries resources was also related to the hydrological factors. In general, better catch (> 116 kg/hr) was obtained from areas having depths of 45–65 m, salinity range of 32.0 – 33.5 ‰ and bottom temperatures above 23°C. However, in the coastal waters off Sarawak and North Andaman Sea (off Burma), good fishing grounds were characterized by low salinity, low temperature and high nutrient contents, suggesting the influence of freshwater discharge in the area. Abundant occurrence of coastal water fishes were found in these areas.

From the present analysis, it appears that the combination and interaction of both hydrological and topographic conditions are important factors contributing towards the formation of good fishing ground in the surveyed areas.

1. INTRODUCTION

It is known that the environmental factors play an important role in the distribution of fisheries resources although the relationship is rather complex. In order to study this relationship the data from the oceanographic and fisheries resource survey carried out by the 387-ton research vessel CHANGI in the southern part of the South China Sea and the Andaman Sea from November 1969 to March 1973 were analysed. Special attention was paid to the various factors contributing towards the formation of good fishing grounds.

2. MATERIAL AND METHODS

Catch data for this study were obtained by experimental trawl fishing by CHANGI, with the use of a

4-seamed net having a head rope length of 36 m and towed at a speed of 2.5 to 4.5 knots. The original trawl catches obtained from each half-degree block of 30 square miles were converted into mean catch per hour for the respective monsoon and intermonsoon seasons.

Catch data obtained from the preliminary exploratory vertical headline fishing in the Andaman Sea in February 1973 were not converted.

Analyses of water samples collected by Nansen (Nansen) reversing bottles and mud samples collected by SK-type sampler were as described in a previous paper (Shirota et al., 1972).

3. RESULTS AND DISCUSSION

From the analyses of the catch data, a comparative study was made between the northeast monsoon, the southwest monsoon and the intermonsoon periods in the South China Sea. As no catch data were available during the southwest monsoon in the Andaman Sea, comparison of catch between the two monsoon seasons in the region was not possible.

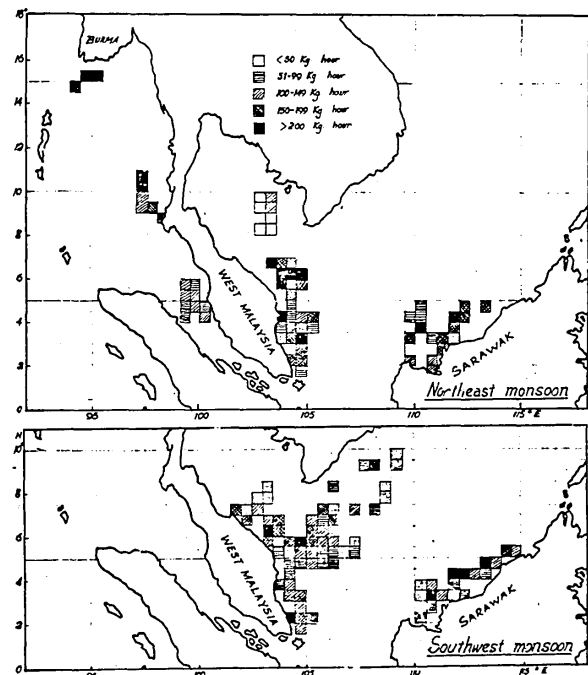

Fig. 1 Variation in trawl catch by block in the northeast and southwest monsoons (1969–73).

Fig. 1 shows the mean catch per hour per block during the northeast monsoon (October-March) and the southwest monsoon (May-August) season. On the whole the mean catch for the respective seasons fluctuated considerably in the South China Sea.

During the northeast monsoon season, high means catch per hour (more than 200 kg) was observed in the 7 blocks along the east coast of the Malay Peninsula and 2 blocks in the west coast of Sarawak, while in the southwest monsoon season, such high catch was observed in 3 blocks along the east coast of the Malay Peninsula and 4 blocks in the west coast of Sarawak. However, during the intermonsoon season, mean catch of similar magnitude was not observed in any block.

Taking into consideration of the above mentioned results the analysis of the environmental factors contributing towards the formation of good fishing grounds was carried out.

3.1 Bottom Feature

Since the distribution of demersal fisheries resources largely depends on the different types of sea beds, which in turn are related to different current movements, there may be a relationship between catch and bottom feature in the South China Sea. The catch data superimposed onto a map illustrating the bottom feature of the South China Sea is shown in Fig. 2. As far as the trawl catch in the South China Sea is concerned no clear relation between the catch and bottom obtained from both sandy and muddy areas.

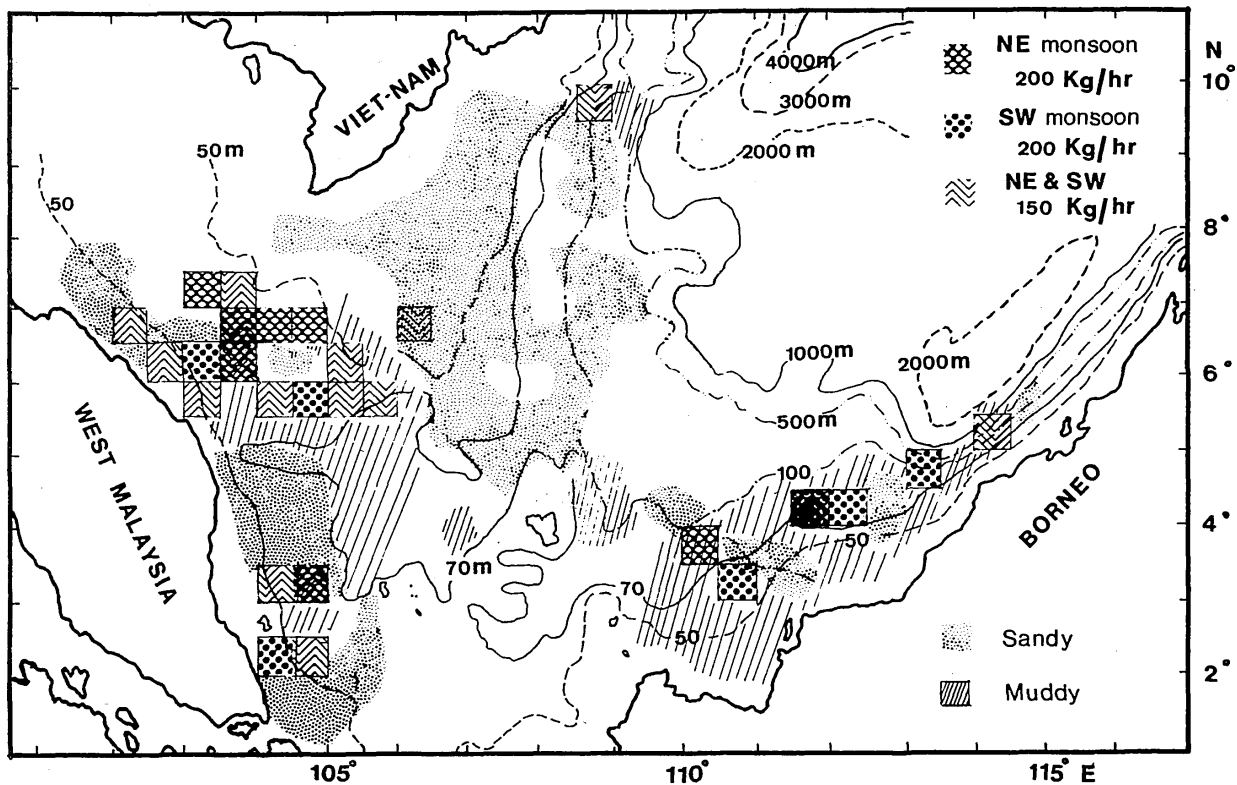

Fig. 2 Bottom feature and mean catch per hour.

3.2 Bottom topography

Fig. 3 shows the bottom topography of the South China Sea, the Straits of Malacca and the Andaman Sea with superimposed catch data. In the area off the Northeastern coast of Sarawak the depth increases sharply from 100 to 1000 m. Upwelling may easily occur when the offshore water moves towards coastal region across the steep continental slope. A similar pattern of bottom topography is also seen in the Andaman Sea from its north western to central part. It can be seen from the figure that good mean catch of more than 200 kg/hr was obtained from these areas. However similar catch was also obtained from the flat area in the southwestern part of the South China Sea where strong upwelling cannot be expected. This may be due to the presence of a boundary

zone formed along the east coast of the Malay Peninsula as explained in the next section.

3.3 Hydrological factors

Fig. 4 shows the relationship between fish catch and hydrological factors in 1971-1972 in the South China Sea. A better fish catch was obtained from areas having depths of 45-65 m, salinity range of 32.0-33.5‰ and bottom temperatures above 23 °C.

Fig. 5 illustrates the surface isohalines drawn from data collected in 1970-1973 by CHANGI during both northeast and southwest monsoons. From the figure it can be seen that the sharp gradient in salinity is located in some areas where the offshore water supposedly intrudes into the coastal water especially along the east coast of West Malaysia and the northwest coast of Borneo where good

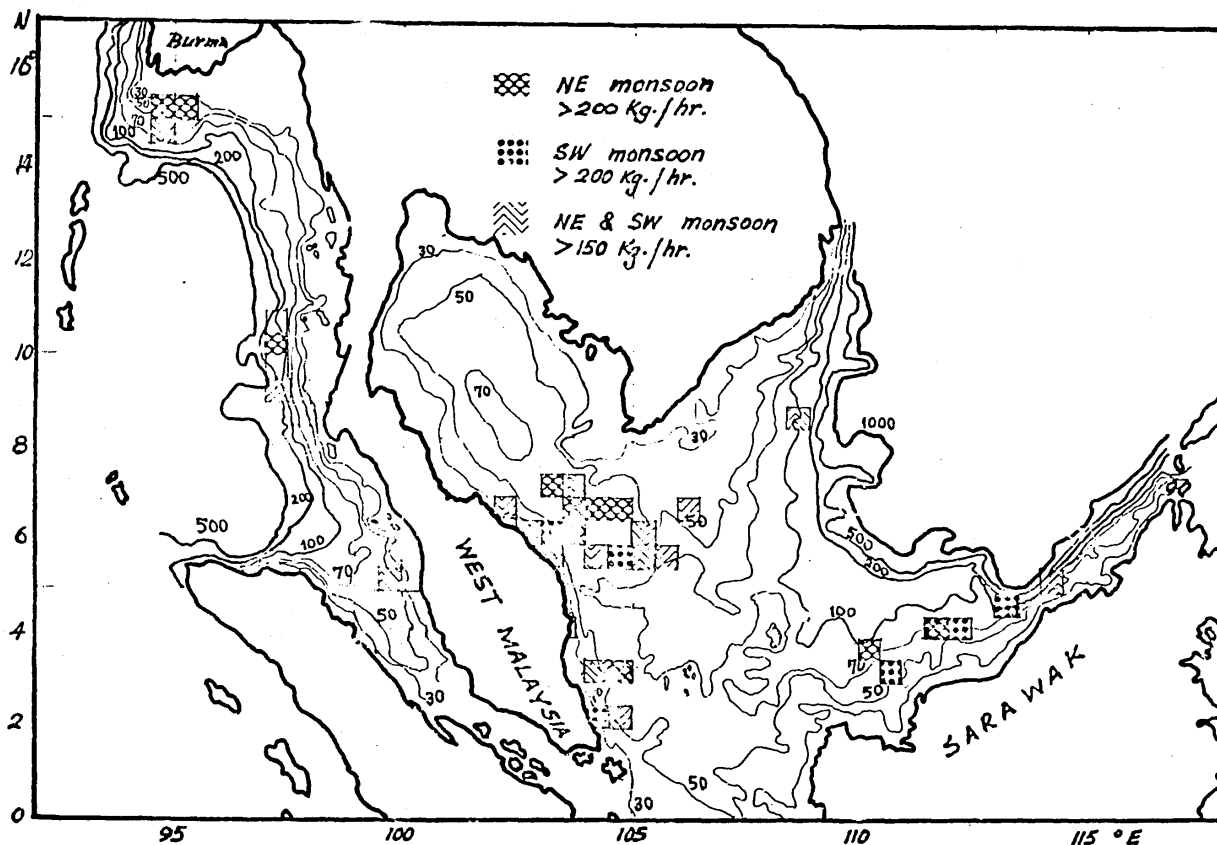

Fig. 3 Bottom topography and mean catch per hour.

mean catch per hour was obtained.

It may be of interest to note that the surface isohaline of 33.5‰ is situated close to the east coast of the Malay Peninsula. This pattern was also observed in both seasons in 1950–1955 (Wyrki, 1961). Thus, a long and narrow strip of boundary zone is formed along the east coast of Malay Peninsula in both monsoon periods, and this may account for the relatively good catch in this area in the northeast and southwest monsoon seasons.

The good fishing grounds in the northwest region (15°00'N, 94-95°30'E) of the Andaman Sea displayed a different hydrological pattern (Fig. 6). This pattern is characterized by low temperature and salinity and high nutrient contents suggesting the influence of considerable freshwater discharge from the Irrawaddi and Sittang rivers.

The Phosphate-Salinity (P-S) diagrams show different patterns between coastal and offshore waters (Fig. 7). There is a tendency that water with high salinity has low PO₄-P contents whereas water with low salinity is accompanied by high PO₄-P contents in coastal waters. However, in offshore waters such tendency has not been observed.

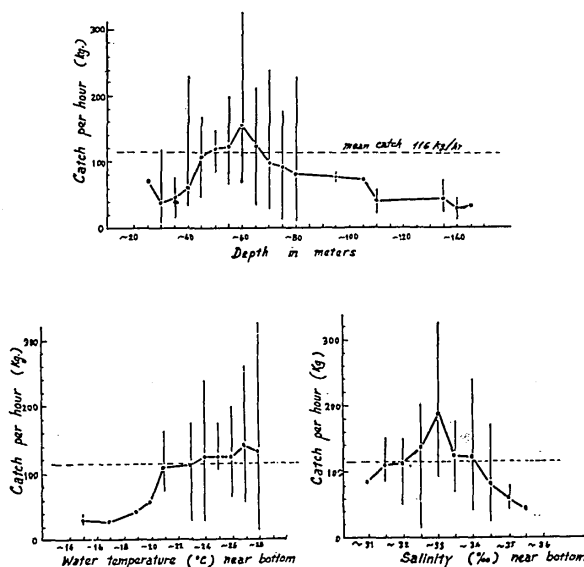

Fig. 4 Relationship between fish catch and environmental factors in the South China Sea (1971–72)

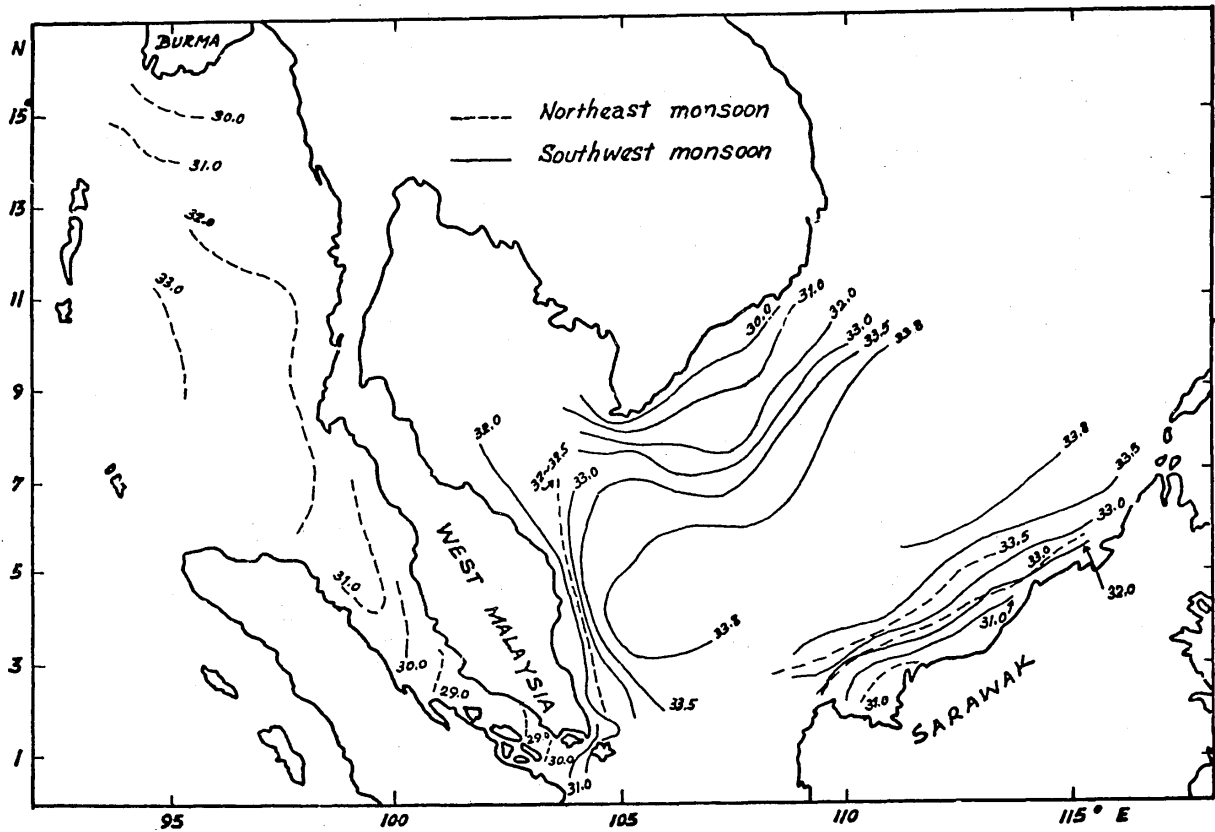

Fig. 5 Distribution of surface salinity in the northeast and southwest monsoons (1970-73)

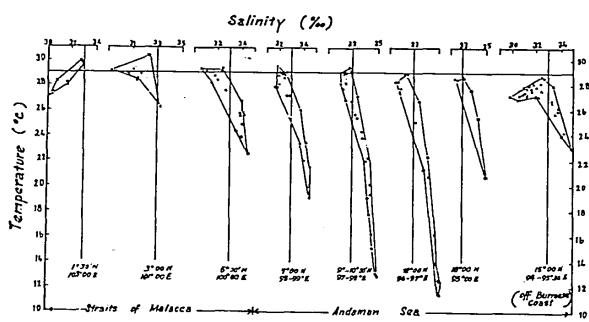

Fig. 6 Temperature-salinity diagrams for the Straits of Malacca and the Andaman Sea in the northeast monsoon.

In the coastal waters of Sarawak and north Andaman Sea good fishing grounds were characterized by low salinity, low temperature and high nutrient contents. In both areas the species composition in catch greatly differed from other areas of the South China Sea especially in the abundant occurrence of croaker, shad, grunter and pomfret. However, in the offshore waters although high PO_4-P contents accompanied by high salinity were found the relation between catch and hydrological condition in these areas were not known.

Recently a preliminary survey on vertical handline fishing was conducted in the eastern part of the Andaman Sea. The fishing grounds were located along the slope where the depth increased suddenly from 100 to 500 m.

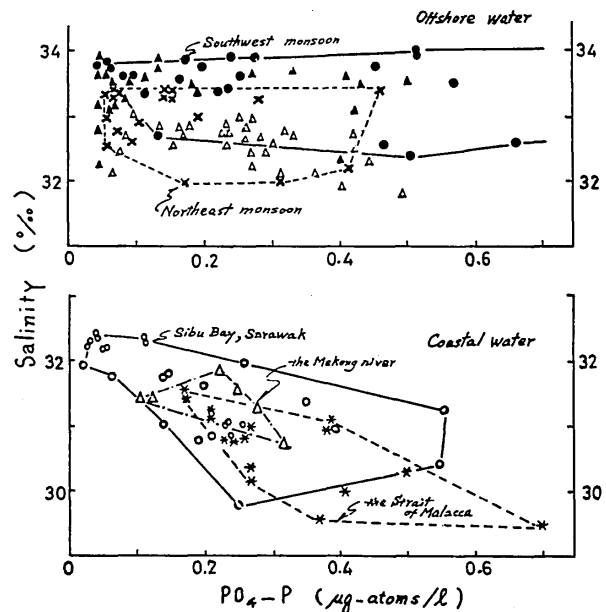

Fig. 7 Phosphate-salinity diagrams for offshore and coastal waters (1971-72)

The fish schools detected by the echo-sounder were very often observed along the edge of the slope. The results are summarized in Table I. Since the fish schools were located in a restricted area the topographical and hydrological factors seem to be important for the formation of good fishing ground.

Table I. Catch by bottom vertical handline fishing in the eastern part of the Andaman Sea in February, 1973.

Date	Location	Time Start End	Operation Time (min)	Total catch (kg)
24 Feb.	997a	12:05–12:33	28	72.2
25 Feb.	1097a	13:15–13:33	18	96.8
26 Feb.	1097a	10:33–13:47	125	622.4
27 Feb.	1097c	15:27–17:28	67	149.8
28 Feb.	1097c	12:10–17:21	100	384.1
1 Mar.	1097a,c	07:01–07:48	47	79.8

4. CONCLUSION

From the above results and discussion it appears that the combination and interaction of environmental factors may determine to a certain extent the distribution of demersal fisheries resources and may contribute towards the formation of good fishing grounds. In this connection environmental factors should not be analysed separately but as a whole. However, in fishing ground along the edge of continental shelf and banks of submarine ridges the distribution of fish may depend to topographic condition

primarily and hydrological condition secondarily.

In view of our limited knowledge further studies need to be carried out on the relationship of environmental factors and the distribution of demersal fisheries resources before such resources can be fully exploited.

ACKNOWLEDGEMENTS

The author is indebted to Mr. Chen Foo Yan, Chief of the Marine Fisheries Research Department, SEAFDEC, for reading the manuscript and giving valuable criticism. The author also extends his thanks to Dr. Satoshi Mito, Deputy chief of the Department, for kindly reading the manuscript and good suggestions. Finally, the author expresses his heartiest thanks to Mr. Mathew Chow for his valuable technical assistance.

References

- Shirota, A., L. C. Lim and M. Chow, 1972. Some oceanographic characteristics of the southern part of the South China Sea. Indo-Pacific Fisheries Council, IPFC/72/SYM 41.
- Wyrtki, K., 1961. Physical oceanography of Southeast Asian Waters. Naga Report, Volume 2, The University of California, Scripps Institution of Oceanography.

SEAFDEC/SCS.73: S-21

Brief Note on the Relationship of Scattering Layer and some Hydro-Biological Factors*

by
Akihiko Shirota

Marine Fisheries Research Department
Southeast Asian Fisheries Development Center
Changi Point, Singapore

Abstract

The analysis of echo-sounding records obtained from the South China Sea showed that scattering layer is caused by a concentrated layer of zooplankton and is related to thermocline. The occurrence of scattering layer may be used to indicate either the depth where thermocline occurs or the vertical movement of zooplankton.

Fish schools were reorded at the vicinity of the scattering layer and this phenomenon is probably associated with the feeding habits of the fish.

1. INTRODUCTION

A scattering layer as recorded on an echo-sounder paper (PLate 1) is caused by the presence of zooplankton. During the survey cruises of the research vessel CHANGI the depth of the scattering layer has been observed to be

* We regret that it is not possible to publish the original "plates" as their condition is no longer suitable for printing.

related to the depth of the thermocline as recorded by the bathythermograph. Since zooplankton is an important source of food for juvenile and plankton-feeding fishes, studies on the relationship of scattering layer and some hydro-biological factors are of some importance to fisheries development in the Southeast Asian region.

2. MATERIALS AND METHODS

CHANGI conducted an oceanographic survey cruise and occupied 21 stations in the South China Sea in April 1971 (Fig. 1). Three additional surveys were also carried out in April–May, June and September of 1972. The echo-sounder used was a SR-11 type (Kaijo-Electric Co. Ltd.) with 200 KC frequency. Continuous graphical records of water temperature in the sea were obtained by the bathythermograph (BT). Zooplankton samples were collected by vertical hauling with a closing net (mouth diameter = 25 cm, mesh size = 24/cm) from various strata of the sea and the wet weight of zooplankton biomass (mg/m³) was recorded.

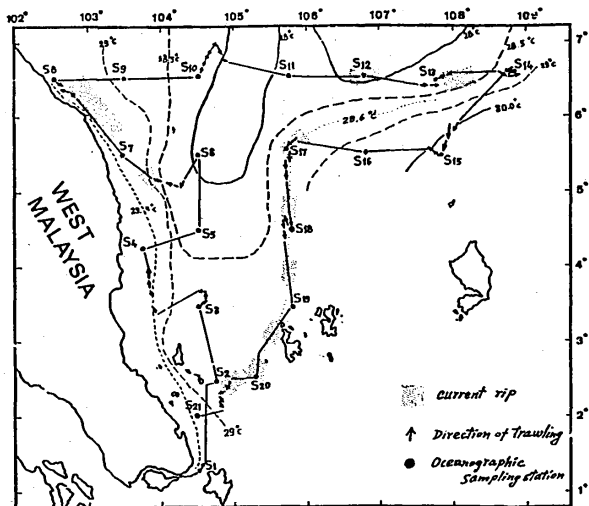

Fig. 1 Oceanographic sampling stations of the survey cruise in April 1971.

3. RESULTS AND DISCUSSION

The relationship between the depth where scattering layer and thermocline occurred are shown in Fig. 2. All the echo-sounding records showed that the scattering layer occurred within the depth range of thermocline. Thus, the occurrence of scattering layer may indicate the depth where the thermocline occurred. The tracing of the scattering layer is darker when the temperature range of the thermocline is wider.

Table I. Variation of plankton biomass in relation to the presence and absence of scattering layer.

Time (hr)	Depth stratum without scattering layer		Depth stratum with scattering layer		
	Depth (m)	Biomass (mg/m ³)	Depth (m)	Range (m)	Biomass (mg/m ³)
18:09	0-40	76	40-80	50-65	124
19:05	0-40	98	40-73	47.5-58	386
15:00	0-40	97	40-71	46-68	314
09:25	0-40	136	40-68	41-60	221
19:38	0-40	131	40-66	41-60	146
20:19	0-40	113	40-69	30-55	134

Table I shows the relationship between the scattering layer and zooplankton biomass. The results indicated that zooplankton biomass at the depth stratum where the scattering layer occurred was higher than those collected outside the layer. Plate 2 shows the movement of the scattering layer. This layer, moving from the bottom towards the surface, was recorded soon after sunset and became stable on reaching the thermocline 90 minutes after sunset. The scattering layer recorded here is probably formed by concentration of zooplankton. Thus, the movement of scattering layer may indicate the vertical movement of zooplankton, as reported by Moore (1950), Suzuki (1963 & 1969), Suzuki & Tsujizaki (1961) and Shirota (1967).

Plate 3 shows traces of fish schools in the vicinity of the scattering layer. It appears that their presence in the congregation of zooplankton is probably associated

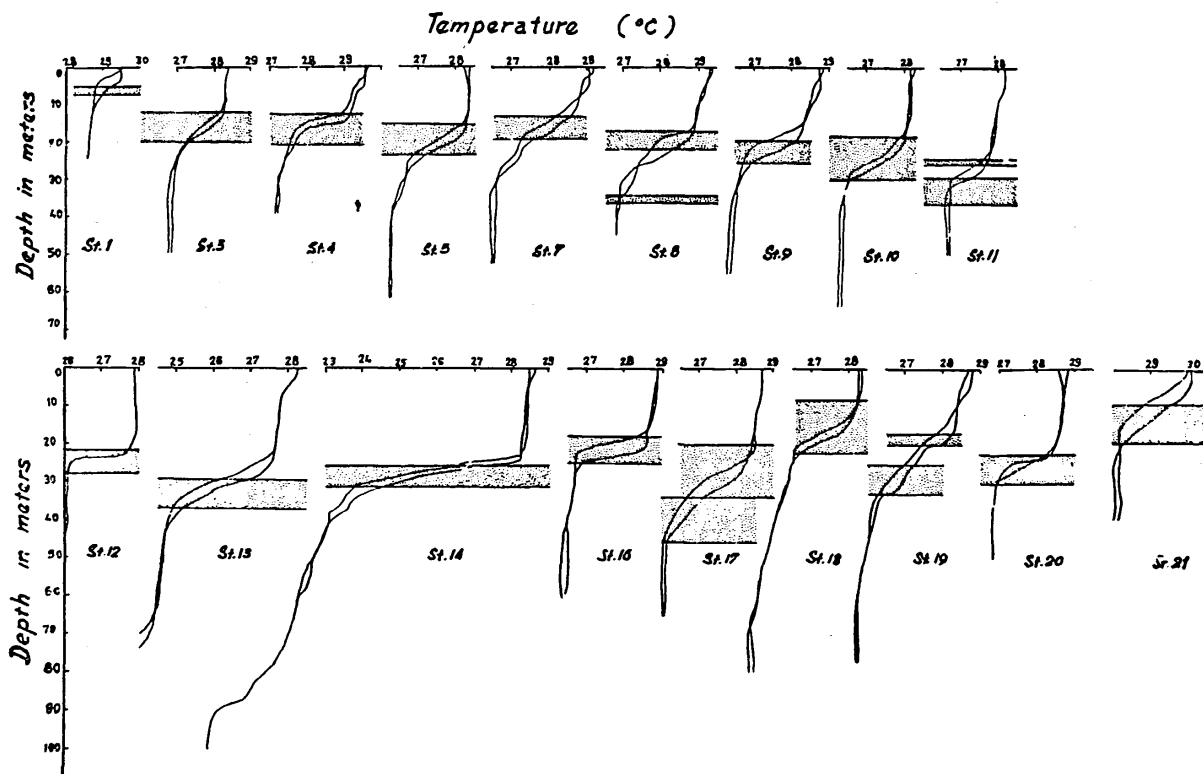

Fig. 2 Relationship between the depth of scattering layer and thermocline in April 1971.

with their feeding habits. The above analysis confirms that scattering layer recorded in the South China Sea is usually a concentrated zooplankton layer. The occurrence of scattering layer may be used to indicate either the depth where thermocline occurs or the vertical movement of zooplankton, the knowledge of which has important application to the development and exploitation of fisheries resources.

4. ACKNOWLEDGEMENTS

The author is indebted to Mr. Chen Foo Yan, Chief of the Marine Fisheries Research Department, SEAFDEC, for his critical reading of the manuscript.

5. References

Moore, H. B., 1950. The relation between the scattering layer and Euphansiaacea. *Biol. Bull.*, 99:181-212.

Shirota, A., 1967. Observations on the scattering layer and fish schools in Nhatrang Bay, South Vietnam. *Inf. Bull. Plantk. Viet-Nam*, 1:37-48.

Suzuki, T., 1963. Studies on the relationship between current boundary zones in waters to the southeast of Hokkaido and migration of the squid, *Ommastrephes sloani pacificus* (Steenstrup). *Memoirs of the Faculty of Fisheries, Hokkaido University*, 2(2):75-153.

Suzuki, T., 1963. Studies on the relationship between current boundary zones in waters to the southeast of Hokkaido and migration of the squid, *Ommastrephes sloani pacificus* (Steenstrup). *Memoirs of the Faculty of Fisheries, Hokkaido University*, 2(2):75-153.

Suzuki, T., 1969. On the under-water ultra sonic wave. (in Japanese) *Marine Sciences, Jap.*, 1(2):44-49

Suzuki, T. and H. Tsujizaki, 1961. On the DSL in the Pacific area west of Cape Erimo of Hokkaido. *J. Hokkaido Fish. Exp. St.*, 18(8):24-32

CURRENT STATUS OF FISHERIES INCLUDING STATISTICS

SEAFDEC/SCS. 73: S-1

Current Status of Fisheries Development in South China Sea Area

by

Tadashi Yamamoto

FAO Fishery Statistician

FAO Regional Office for Asia & Far East

Abstract

A brief review of current status of fisheries development in South China Sea is made based on fishery statistics currently available. The results are summarized as follows:

- (1) During the past decade the number of inboard powered boats operating in South China Sea area increased by 470%. Furthermore, a good number of fishing boats exceeding 100 gross tons have also appeared.
- (2) During the same period there appeared a massive explosion of trawl fishery in every country.
- (3) The present level of marine fishery production in the area is supposed to be some 4 million metric tons valued at about US\$800 million. Although numerous fisheries exist trawl, purse seine and drift gill net fisheries have played a leading role and these three fisheries alone produced 55% of the total marine catch in the area.

1. INTRODUCTION

The present paper briefly reviews the current status of fisheries development in South China Sea area with a hope that it could serve, to some extent, as a background paper to the Technical Seminar on South China Sea Fisheries Resources. However, the author admits that due to scarcity and unreliability of national fisheries data currently available various reviews made in the paper are

undoubtedly not conclusive.

Owing to the nature of the seminar various reviews made in the present paper are referred to marine fisheries in South China Sea and those in Malacca Strait and the southern half of Formosa Strait.

2. ENLARGEMENT OF FISHING FLEET DURING THE PAST DECADE

Fishing boats in the area under study are broadly classified into three categories, i.e. (1) Non-powered boat, (2) Outboard powered boat and (3) Inboard powered boat. Table 1 shows how the number of fishing boats for each of those categories has been changed during the past decade.

Although nothing can be clearly mentioned due to the incompleteness of data comparable among countries, the structural change of fishing fleet in the area can be summarized as follows:

- (1) As for non-powered boat and outboard powered boat there is a clear sign that the number of these boats is decreasing although the tempo is rather slow. Whereas, as for inboard powered boat a marked increase of such boats is noted. As a matter of fact, during the past decade the number of non-powered boats increased by 22%, whereas that of inboard powered boat increased by 470%.
- (2) However, an increasing rate of the number of inboard powered boat differs among countries.

Table I. Number of Fishing Boats in 1960, 1965 and 1970

	Non-Powered			Outboard Powered			Inboard Powered		
	1960	1965	1970	1960	1965	1970	1960	1965	1970
Total ^{1/}	67,135	63,148	52,533				14,766	31,911	69,717
China (Taiwan) ^{1/}	5,917	4,871	3,480	—	—	—	5,541	8,167	10,515
Hong Kong	6,969 ^{2/}	2,503	...	—	—	—	2,353 ^{2/}	6,097	...
Philippines ^{3/}	261	327	223	—	—	—	1,238	2,066	2,061
Vietnam ^{4/}	37,477	46,240	42,612	2,684 ^{4/}	12,240 ^{4/}	42,603 ^{4/}
Khmer ^{5/}	18,908	19,200	...	70	250	...	135 ^{2/}	1,100	...
Thailand	...	16,584	8,313	10,448	8,760
W. Malaysia	14,608	10,182	5,277	3,938	3,908	2,164	5,002	8,374	12,865
Sarawak	1,572	—	—	881	1,003
Sabah	6,813	440	300	—	2,000	2,320	141	875	1,400
Singapore	2,059 ^{2/}	1,088	361	620 ^{2/}	434	298	160 ^{2/}	189	273
Sumatra ^{6/}	35,352	3,974

^{1/} Only a sum of China (Taiwan), Philippines, Vietnam, W. Malaysia, Sabah & Singapore.

^{1/} No. of fishing boats for Taiwan as a whole.

^{2/} 1958 figures.

^{3/} Only No. of commercial fishing vessels exceeding 3 gross tons.

^{4/} Includes No. of outboard powered boats.

^{5/} Includes No. of fishing boats in inland waters.

^{6/} No. of fishing boats based in Sumatra.

— Not available.

... Available, but the figure is not available.

Table II. Number of Trawlers in Around 1971

Country or State	Type of trawlers	Total	Number of Trawlers by Tonnage Class					Year referred
			Less than 10GT	10-20	20-30	30-50	50 & over	
China (Taiwan)	Otter	1,506	703	340	—	463	—	1970
	(Pair)	195	—	—	—	—	195 ^{1/}	1970
Hong Kong ^{2/}	(Otter (Stern))	60	—	—	—	—	60	1972
	(Pair (Modern))	140	—	—	—	—	140	1972
	(Pair (Native))	180	—	—	—	—	180	1972
Philippines ^{3/}	Otter	653	14	68	90	163	318	1970
Vietnam ^{4/}	Pair	Ca. 3,000	—	Ca. 3,000	—	1972
Khmer	Otter	219	33	166	15	5	—	1972
Thailand ^{5/}	(Otter)	2,401	843	1,056	502	1971
	(Pair)	530	—	—	216	314	—	1971
W. Malaysia ^{4/}	Otter	4,272	—	Ca. 3,600	—	Ca. 600	—	1971
Sarawak	Otter	400	—	1972
Sabah	Otter	294	—	1971
Singapore	Otter	118	—	1970
Sumatra	Otter	Ca. 200	—	...	—	Ca. 200	—	1972
Total		14,168						

^{1/} Out of 195 trawlers 152 were 100 G.T. and over.

^{2/} Exclude shrimp trawlers in shallow waters.

^{3/} No. of baby trawlers is excluded.

^{4/} No. of baby trawlers is included.

— Not available.

... Available, but the figure is not available.

a. Countries or states where a marked increase of inboard powered boat was achieved were: China (Taiwan), Hong Kong, Vietnam, West Malaysia and Sabah.

b. Countries or states where an increase of inboard powered boat was moderate were: Philippines, Sarawak and Singapore.

c. Countries or states where an increase of

inboard powered boat was rather slow were: Sumatra and Khmer.

(3) During the past decade fishing capacity in South China Sea area has increased not only in terms of the number of inboard powered boats but also in terms of the size of fishing boats, although statistical data that clearly indicates such a trend are not available. For example, the size of some

trawlers in China (Taiwan) and Thailand has exceeded 100 gross tons. Average size of trawlers in Vietnam which was less than 10 gross tons in around 1960 has now become 20 gross tons.

Country or State	Approximate Year when Trawl Fishery Appeared
China (Taiwan)	before 1960
Hong Kong	before 1960
Philippines	before 1960
Vietnam	1955
Khmer	1970
Thailand	1960
W. Malaysia	1965
Sarawak	1968
Sabah	1962
Singapore	1965
Sumatra	1967

3. MASSIVE EXPLOSION OF TRAWL FISHERIES IN RECENT YEARS

As seen below, the historical development of trawl fisheries in South China Sea area is still young.

Nevertheless, as seen in Table 2 a massive explosion of trawl fisheries is noted in every country, the total number of trawlers in the area as a whole being 14,000. It must be stressed that this is really a notable fact in the history of fisheries development in South China Sea area.

The author does not have enough time to describe how the trawl fishery was developed in each area. However, he may illustrate some particular features of trawl fisheries in each country or state during the course of the Seminar.

Table III. Total Marine Catch by Countries or States and by Major Type of Fisheries
— South China Sea —

	Total	Important Fisheries throughout Countries				Locally Important Fisheries			Other Fisheries	Year referred	
		Sub-total	Trawls	Purse Seine	Drift net ^{5/}						
Total	3,750.0 (100)	2,091.4 (55)	1,545.6 (41)	314.3 (8)	231.5 (6)		487.5 (13)		1,171.1 (32)		
China (Taiwan) ^{1/}	225.4 (100)	122.2 (54)	112.8 (50)	4.4 (2)	5.0 (2)				103.2 (46)	1970	
Hong Kong	73.8 (100)	58.2 (79)	48.0 (65)	4.5 (6)	5.7 (8)	Longline	10.4 (14)		5.2 (7)	1971	
Philippines	892.4 (100)	222.7 (15)	135.6 (15)	86.7 (10)	0.4 (0)	Bag Nets (Lift net)	125.5 (14)	Moro-Ami (2)	16.8 (2)	527.4 (69)	1970
Vietnam ^{2/}	516.4 (100)	387.3 (75)	258.2 (50)	51.6 (10)	77.5 (15)				129.1 (25)	1970	
Khmer ^{3/}	39.4 (100)	31.5 (80)	27.2 (69)	3.5 (9)	0.8 (2)				7.9 (20)	1971	
Thailand	1,246.2 (100)	799.3 (64)	658.9 (53)	75.1 (6)	65.3 (5)	Sea Mussel collecting	288.8 (23)		158.1 (13)	1971	
West Malaysia	317.9 (100)	219.5 (69)	112.2 (35)	88.5 (28)	18.8 (6)	Bag Nets (stow net)	26.0 (8)	Lift Nets (6)	15.7 (6)	56.7 (17)	1971
Sarawak ^{4/}	25.5 (100)	19.8 (77)	12.8 (50)	—	7.0 (27)				5.7 (23)	1971	
Sabah ^{4/}	57.8 (100)	38.1 (67)	38.1 (67)	—	...				19.7 (33)	1971	
Brunei	1.9 (100)						
Singapore	15.2 (100)	5.8 (38)	5.8 (38)	—	—	Trolling	4.3 (28)		5.1 (34)	1971	
Sumatra ^{2/}	340.0 (100)	187.0 (55)	136.0 (40)	—	51.0 (15)				153.0 (45)	1970	

Units: 1,000 metric tons; figures in parenthesis are % against the national total catch.

^{1/} Only catches which were supposed to be caught in South China Sea and Formosa Strait are given.

^{2/} Catch by types of fisheries is approximation made by the author.

^{3/} Total catch of 39.4 thousand metric tons includes an estimate of 7.9 thousand metric tons which is supposed to be caught by subsistence fisheries.

^{4/} Trawl's catch officially disclosed does not include trash fish.

To make trawl's catch comparable among countries the quantity of trash fish estimated is included.

^{5/} Only catches which were supposed to be caught in Malacca Strait are given.

^{6/} Drift net includes both Spanish mackerel and Indo-Pacific mackerel (Rastrelliger) drift nets.

^{7/} The types of locally important fisheries will be more than those listed here if a careful study is made further for each country.

4. CURRENT LEVEL OF FISHERIES PRODUCTION IN SOUTH CHINA SEA AREA

Owing to a great difference on the reliability of catch statistics among countries there is a great danger to give the magnitude of fisheries production in the area. However, an attempt was made to do so based on catch data currently available in each area, and the result is given in Table 3.

From figures given in Table 3 particular natures of marine fisheries in South China Sea area may be summarized as follows:

(1) Magnitude of Total Marine Fisheries Production

The magnitude of total marine fisheries production throughout the area is now supposed to be some 3.75 million metric tons excluding catches taken by China Mainland and North Vietnam. If 250 thousand metric tons of catches is assumed for those two areas, the total marine fisheries production for the South China Sea area would be some 4 million metric tons.

If an average price of US\$0.2 per Kilogramme or US\$200 per metric ton is assumed, the total value of fisheries production for the area as a whole would be some US\$800 million.

(2) Major Fisheries

Due to the tropical nature of the waters a variety of fishes are caught by a number of different types of fishing gears. However, as seen in Table 3 major types of fisheries which play a leading role in the total fisheries production are very limited. Trawl, purse seine and drift gill net fisheries are those which more or less commonly appear in each country, producing 55% of the total marine catch in the area. Besides those three

major fisheries each country or area has its own locally important fisheries, the examples of which are given in Table 3.

Of the three major types of fisheries trawl fisheries alone produce 41% of the total marine catch. However, one must be aware that 60 to 80% of trawler's catch is trash fish which is not edible by human being. Thus, out of 1.5 million metric tons of fishes caught by trawlers only 450 thousand metric tons of fishes are supposed to have been consumed by human being.

The share of purse seine and drift gill net fisheries to the total marine fishery production is at present only 8 and 6% respectively though these are commercially important fisheries in the area. This implies that there is a certain possibility to increase fish production with those fishing gears provided that further exploitable pelagic resources are available.

Finally, it may be worthwhile to stress that long line fishery either in the form of a drift or bottom long line has hardly been developed in the area with the exception of Hong Kong and Singapore. The reason may be that a rapid and massive development of trawl fisheries in the area has hampered the development of this fishery. However, in the light of the fact that a long line can be effectively used in untrawlable areas like coral reef, rocky sea area, etc. and the cost of constructing the gear is far cheaper than that for purse seine and drift gill net, the possibility of exploiting untouched fisheries resources with this gear should be explored.

SEAFDEC/SCS.73: S-2

Fishery Statistics Required for the Stock Assessment of Fisheries Resources in South China Sea Area

by

Tadashi Yamamoto
FAO Fishery Statistician
FAO Regional Office for Asia and the Far East

Abstract

Existing national marine fishery statistics and proposals for the improvement are reviewed under the following headings;

- (1) Definition of Catch
- (2) Measurement of Gross Tonnage
- (3) Standardization of National Statistical classifications
 - i. Tonnage classification
 - ii. Species classification
 - iii. Fishing Gear Classification
- (4) Establishment of Fishing Area Classification in

South China Sea Area

- (5) Types of Statistical Tables Required for International Comparison.

In designing any statistical survey the first thing to do is (1) to establish clear definitions or concepts for survey items and classifications to be used in the survey and (2) to work out statistical tables which might well meet the requirements of users. These kinds of works are particularly important when international comparison of fishery statistics is required. Therefore, reviews and proposals hereunder are made along the above line with respect to some pertinent points.

1. DEFINITION OF CATCH

"Catch" is the most important survey item among a number of survey items being sought in fishery statistics. However, when a review is made to the instructions of catch survey throughout countries under study, the definition of catch is either entirely lacking or incomplete. This will naturally lead to inconsistency to catch figure being collected not only within the same country but also between countries. For example, in certain countries only the meat of shellfish is considered as catch, whereas in other countries both meat and shell are treated as catch.

FAO definition of catch is described by referring to the case of advanced fisheries in other regions. As a result, it is too difficult for Asians to understand the exact meaning. It is, therefore, proposed that another version of catch definition which will really fit to the status of Asian fisheries be worked out without destroying anything about the meaning of catch defined by FAO. Perhaps, IPFC/IOFC JWP is the most appropriate organ to take up this matter, since the above difficulty has been encountered by the majority of countries in the region of IPFC/IOFC.

As has been reviewed at country level, in Sabah and Sarawak, trash fish caught by trawlers are discarded into the sea, whereas in other countries trash fish are normally brought back to ashore for fish meal, manure, etc. Hence, the national catch of Sabah and Sarawak does not include trash fish, whereas that of other countries includes trash fish. According to catch definition established by FAO both treatments are correct. However, these facts may cause a serious problem when a biological productivity of fisheries resources in South China Sea is studied. Therefore, a certain principle with regard to the treatment of trash fish may have to be established as an exceptional case of FAO catch definition.

2. MEASUREMENT OF GROSS TONNAGE

Tonnage record for an individual powered fishing boat is available throughout countries under study. However, as has been pointed out by the 2nd session of IPFC/IOFC JWP, there are great differences among countries with respect to the measurement of gross tonnage. It is apparent that this situation will cause a serious problem for international comparison of fishing fleet statistics as well as catch/fishing effort data, since comparative studies of these data among countries will often have to be made according to the tonnage classes of a fishing boat.

However, it is unlikely that this problem can be easily solved within a short period, since in many countries the way of measuring gross tonnage has been firmly established by Government organization other than the Department of Fisheries and it is also applied to boats other than fishing boats. Therefore, one of the solutions would be to seek a certain coefficient for each country, by which tonnage figures which have already been measured by present methods are converted into comparable tonnage among countries.

Once such a coefficient is obtained for each country, the work of converting national tonnage into comparable

tonnage would be very simple. However, in order to obtain an adequate coefficient a good knowledge of a gross tonnage measurement and a good amount of patient work to measure actual tonnage of fishing boats are required. In practice, a sample of say 50 inboard powered boats are selected for each country, and the measurement of real gross tonnage is made for each sample boat in a standardized way. In this way, the coefficient is obtainable by dividing the sum of local tonnages which are already available by the sum of real tonnages which are newly measured. It may be apparent that in order to achieve this task throughout all countries concerned at least one year's service of a UNDP expert in the field of naval architecture is required.

3. STANDARDIZATION OF NATIONAL STATISTICAL CLASSIFICATIONS

There are three classifications for which the review and proposals are required.

3.1 Tonnage Classification

Only Philippines, Khmer, West Malaysia and Sarawak have established tonnage classifications, of which the one for West Malaysia has to be revised so as to cope with IPFC/IOFC proposed tonnage classification. Since a tonnage classification proposed by IPFC/IOFC will fit to the structure of fishing fleet in the area, there will be no difficulty for the rest of countries to adopt a similar tonnage classification.

3.2 Species Classification

Of 10 countries under review Hong Kong, Philippines, Thailand, West Malaysia, Sarawak and Singapore have a fairly comprehensive species classification. Species classification in Khmer is in need of further development. Thus, Vietnam, Sabah and Indonesia are only the countries which do not have any species classification. For the comparative study of catch by species among countries there are two important conditions which have to be satisfied; (1) commercially important species are properly selected as statistical categories throughout all national species classifications and (2) catch data by species so selected are adequately comparable among countries. However, so far no such careful study has been made in these respects.

For the study of how far these conditions are satisfied the most important point to be kept in mind is that for the collection of catch data by species one has to refer to commodity categories which have been traditionally established by both fishermen and fish dealers. Hence, national species classification has to be established primarily in terms of such commodity categories. Such a commodity category often includes more than one species. Therefore, unless taxonomic components of such commodities categories are carefully studied from country to country, nothing can be evaluated with regard to the above two conditions.

In view of the fact that this study involves tremendous patient work by both fishery biologist and fishery statistician IPFC has so far recommended that at least one year's services of internationally recruited expert be required to accomplish this troublesome task.

3.3 Fishing Gear Classification

Comparing with species classification fishing gear classification has been far less developed in countries under review. At present, only Thailand, West Malaysia, Sarawak and Singapore have established their own national fishing gear classifications. However, of these four countries a cross tabulation of marine catch by species and by types of gear is done only in Thailand, West Malaysia and Sarawak. In Hong Kong, Philippines and Khmer fishing gear classification is applied to part of marine catch mostly limiting to major fisheries.

For establishing a new national fishing gear classification or for revising an existing national fishing gear classification an international fishing gear classification proposed by IPFC/IOFC JWP should be followed as far as possible. Unlike species classification this task does not involve much difficulty, since types of fishing gears dominantly in use throughout a country are fairly well known by many people. However, to facilitate this kind of work without any misunderstanding the definitions of fishing gears which were partly discussed in the 2nd session of IPFC/IOFC JWP should be finalized as early as possible.

4. ESTABLISHMENT OF FISHING AREA CLASSIFICATION FOR SOUTH CHINA SEA

Establishment of fishing area classification is a prerequisite to compile catch and fishing effort data by fishing areas, which are indispensable for stock assessment as well as fisheries management. At present, Hong Kong, Philippines, Khmer, Thailand and Sabah have established their own fishing area classifications. However, since these area classifications have been established purely for national use, water areas covered are limited to part of South China Sea and further the size of unit fishing area differs from country to country. Therefore, there is a need of establishing a new fishing area classification which will cover the entire area of South China Sea and Malacca Strait.

Establishment of subareas within FAO major fishing area 71, i.e. "Western Central Pacific", is now under study by IPFC/IOFC JWP. However, since it has been decided that closed sea areas such as Red Sea and South China Sea will be a unit sub-area, a matter of establishing fishing area classification within South China Sea may not be taken up by the JWP. It is, therefore, considered that this is a matter entirely to be taken up by the South China Sea

Programme if catch and fishing effort data have to be compiled by fishing areas. Considering a recent massive expansion of trawl fishery in South China Sea it would be wise that a new fishing area classification is established primarily for the study of demersal resources.

5. TYPES OF STATISTICAL TABLES REQUIRED FOR INTERNATIONAL COMPARISON

It may not be too much to say that at present there is no comparable fisheries data available throughout 10 countries with an exception of the total number of fishing boats and the magnitude of total marine catch. Thus, even the number of trawlers which has markedly increased in recent years and which is the most indispensable figure to initiate the study of stock assessment for demersal resources is not clearly known in many countries. This is due largely to absence of statistical tables to be commonly compiled by every country.

It may now be clear that the first thing to be taken up by the South China Sea Programme is to set up clearly the minimum requirement of national fishery statistics in the form of statistical table, examples of which are given in Appendix 1, and to let the participating countries understand the significance. As a matter of fact, this is the first and the most essential task to be achieved before considering the improvement of survey methodology.

Types of statistical table given in Appendix 1 are rather ideally worked out. Therefore, there will be several points which may have to be disregarded during the initial stage of data collection. For example, at the initial stage the number of powered fishing boats may be collected only by tonnage classes ignoring the type of fishing gear employed, and fishing effort data for trawl fishery may be limited to the number of fishing units and the number of trips. All these matters should be determined taking into account the current progress of national fishery statistical system

In Appendix 1 it has been suggested that fishing effort data be collected for selected important fisheries. Although nothing can be concluded at this stage, the author got an impression, during the course of his country visit for the South China Sea Programme, that at least trawl, purse seine, Spanish mackerel drift net and partly Rastreliger drift net should be considered as selected important fisheries throughout the entire area of South China Sea (See Table 2 of "Current Status of Fishery Development in South China Sea area, SEAFDEC/SCS.73: S-1).

Appendix 1

Statistical Tables Required for Stock Assessment

Statistical tables given below were prepared merely for the evaluation of existing national fishery statistical system and hence are still provisional. These tables would be carefully studied in the course of Phase II of South China Sea Programme as well as in the third meeting of the IPFC/IOFC JWP to be held in early 1974.

Contents

Name of Table	Priority
1. Fishing Boat	
1.1 Number of Fishing Boats by Tonnage Classes and Types of Fishing Gear	A
1.2 Total Tonnage of Fishing Boats by Tonnage Classes and Types of Fishing Gear	B
1.3 Total Horse Power of Trawlers by Sizes of Trawler	B
2. Catch and Fishing Effort	
2.1 Total Catch by Species and by Types of Fishing Gear	A
2.2-A Summary Account of Selected Important Fisheries	A
2.2-B Fishing Effort and Catch by Fishing Areas for Selected Important Fisheries	A

(Note) A: Essential, B: Desirable

1.1 Number of Fishing Boats by Tonnage Classes and by Types of Fishing Gears

Type of Fishing Gears ¹⁾	Size of Boat ²⁾ Total	Non-Powered boat ³⁾	Out-board Powered boat ³⁾	Inboard Powered Boat ⁴⁾					
				Sub Total	0-5 G.T.	5-10 G.T.	10-20 G.T.	20-50 G.T.	50-100 G.T.
Total									
Otter Trawl									
Pair Trawl									
Beam Trawl									
Danish Seine									
Beach seine									
Fish Carrier ⁵⁾									

- 1) Type of fishing gears is listed in the order of those given in Proposed International Statistical Classification of Fishing Gear (See Appendix IX of FAO Fisheries Reports No. 120)
 - 2) Size classification of fishing boat will be that proposed by JWP. (See 3.1 of FAO Fisheries Reports No. 85)
 - 3) Further classification for these categories is optional with the requirement of a national government.
 - 4) In each tonnage class, the lower limit is included and the upper limit excluded.
 - 5) A boat which is exclusively used as a fish carrier.
- (General Note) It would be ideal that all fishing boats are classified in accordance with Proposed International Statistical Classification of Fishing Gear. However, if this is not possible, classification of fishing boat by type of fishing gear is to be made at least to fishing gears, for which both catch and fishing effort data are sought.

1.2 Total Tonnage of Fishing Boats by Tonnage Classes and by Type of Fishing Gears

Type of Fishing Gears	Size of Boat Total	Non-Powered boat	Out-board Powered boat	In-board Powered Craft	
				Total	Total
Total					
Otter trawl					

- The type of statistical table is exactly identical to that of 1.1. However, the total tonnage of "Non-powered boat" and "Out-board powered boat" is not always meaningful, and hence these are optional with the requirement of a government.
- (General Note) The same as given in 1.1.

1.3 Total Horse Power of Trawlers by Sizes of Trawler

Size of Boat Type of Trawl	Total	Outboard Powered boat ¹⁾	Inboard Powered Boat ³⁾					
			0-5 G.T.	5-10 G.T.	10-20 G.T.	20-50 G.T.	50-100 G.T.	100-200 G.T.
Total								
Otter trawl								
Pair trawl								
Beam trawl ²⁾								

1) Optional

2) Optional

3) Tonnage classes should be the same as those proposed by IPFC/IOFC JWP. However, the further classification of some tonnage classes would be required depending on the requirement of a national government.

2.1 Total Catch by Species and by Types of Fishing Gears

Unit: Metric ton

By Type of Fishing Gears ¹⁾	Total	By Species ²⁾	
Total			

1) Type of fishing gears will be in the order of those in Proposed International Statistical Classification of Fishing Gear (See Appendix IX of FAO Fisheries Report No. 120)

2) Species will be arranged in accordance with International Standard Classification of Aquatic Animals and Plants (ISSCAAP)

(General Note) This statistical table will be compiled for all marine catches.

2.2 (A) Summary Account of Selected Important Fisheries¹⁾

Size of Boat	No. of Fishing Units ²⁾	No. of Trips ²⁾	No. of Days Absent ²⁾	No. of Days Fished	No. of Hauls ³⁾	No. of Trawling Hours ³⁾	Total Catch	
							in Quantity ²⁾	in Value ⁴⁾
Total								
10-20 G.T.								
20-50 G.T.								
50-100 G.T.								
100-200 G.T.								

1) This statistical table is compiled for each of selected important fisheries separately, for which both fishing effort and catch data are sought. The above table is an example for trawl fishery.

2) "No. of fishing units", "No. of trips", "No. of days absent" and "catch in quantity" would be the minimum requirement for every selected important fisheries.

3) These two items should be changed in accordance with the type of fisheries to be covered.

4) To study relative economic importance between different sizes of fishing boat the total catch in value for every size of boat is assessed using average weighted price per unit weight for every species and catch in quantity by species which is obtainable from Table 3.2.2.

2.2 (B) Fishing Effort and Catch by Fishing Areas¹⁾ for Selected Important Fisheries

Type of Fishery _____		Tonnage Class of Boat _____						
Items		By Fishing Areas ²⁾						
		Total	I	II	III	IV	V
Fishing Effort	No. of Trips							
	No. of Days Absent							
	No. of Days fished							
	No. of Hauls							
	No. of Trawling HOURS							
Catch by Species	Total							
	a							
	b							
	c							

1) This statistical table is compiled separately for each tonnage class of boat even within a same fishery.

2) Fishing areas are those which were established to meet the national requirement. It is, however, assumed that such national fishing areas will be established within the area of "sub-area" which will be proposed by IPFC/IOFC JWP in the near future.

SEAFDEC/SCS.73: S-18

Current Status of Research Activities of the Marine Fisheries Research Department, Southeast Asian Fisheries Development Center (1970 - 1972)

by
Chen Foo Yan and Satoshi Mito

1. INTRODUCTION

The Southeast Asian Fisheries Development Center (SEAFDEC), established in 1968, is one of the first concrete regional projects born out of a series of Ministerial Conferences for the Economic Development of Southeast Asia. The Center is governed by a Council, a policy making body, consisting of six Directors, representing six countries, viz. Japan, Malaysia, Philippines, Singapore, Thailand and Vietnam.

The Marine Fisheries Research Department (MFRD) hosted by Singapore is one of the departments of SEAFDEC, the other being the Training Department in Bangkok, Thailand. The functions of the Research Department are:

- (i) to develop the fishing grounds in Southeast Asia by experimental fishing
- (ii) to carry out research into fishing gears, equipment, fishing methods and general handling of fish at sea, in close cooperation with the Training Department
- (iii) to conduct investigation of fisheries resources and research in fisheries oceanography for Southeast Asian countries
- (iv) to train research personnel and technicians, and
- (v) to undertake such other activities as may be determined by the Council.

The Department consists of three sections, the Fish-

eries Resources Section, Fishing Ground Development Section and the Ocean Research Section, and owns a 387-ton stern trawler research vessel CHANGI. It has a staff of 47, including 10 scientists and a crew of 25.

Although the Department has been in operation since April 1969 its regular research activities commenced in January 1970. Research was mainly centred around trawl fisheries and oceanographic survey in the South China Sea. However, in 1972, a programme was set up to include exploratory survey of the Straits of Malacca and the Andaman Sea, and the use of other gear, such as tuna longline, bottom longline and vertical handline for studies of demersal fisheries resources in the Southeast Asian waters. Research scientists from member Countries also participated actively in the research programme of the Department.

Up to April 1973 CHANGI carried out 32 survey cruises in 370 navigational days. Raw data obtained from every cruise are compiled and circulated immediately to Member Countries as Quick Reports, while the Department's Quarterly Newsletter and Annual Report summarising the progress of its activities are published for wider circulation.

This paper summarises research findings of the Department while detailed results may be found in 15 papers presented at the Technical Seminar on the South China Sea of SEAFDEC.

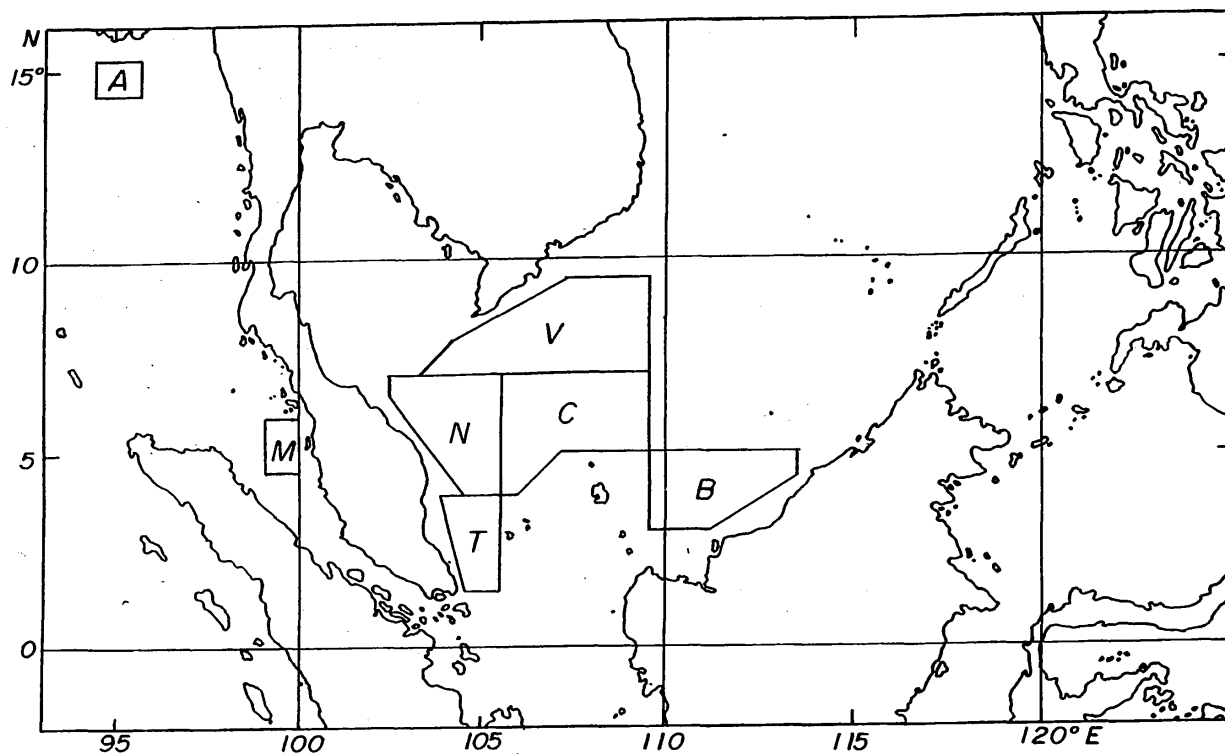

Fig. 1 Trawl fishing grounds surveyed by R.V. CHANGI (1970-73)

2. TRAWL FISHING SURVEY

2.1 Outline of survey

From January 1970 to September 1972 CHANGI carried out experimental bottom trawl fishing and oceanographic survey in the South China Sea. The purpose of the survey was to collect overall demersal fisheries resources and oceanographic information in an extensive area and not to investigate any particular area intensively. However, since October 1972 the survey cruises have been modified, placing greater emphasis on economic feasibility studies in known fishing grounds in the South China Sea. During the latter period, CHANGI has also expanded her survey area to the Straits of Malacca, and North Andaman Sea. The various areas surveyed (T, N, B, V, C, M and A) are illustrated in Figure 1 and the number of trawl hauls, total catch and mean catch per hour by area and by year are summarised in Tables I and II.

2.2 Catch per hour and its fluctuation

From the results of the quantitative and qualitative analyses of catch obtained from the designated areas in the South China Sea it has been found that mean catch per hour varies from area to area, with the catch fluctuating greatly from haul to haul even within the same area. However, these areas can roughly be divided into three types of fishing ground with high and comparatively stable catches, intermediate fishing ground and poor fishing ground. It is perhaps worth mentioning that even in the poor fishing ground some of the hauls yielded very good catches.

Catch records collected by CHANGI and the training vessels PAKNAM of the Training Department (SEAFDEC), and JURONG of the Singapore-FAO/UNDP

Fisheries Training Centre and the research vessel HAI-CHING of the Taiwan Fisheries Research Institute were analysed and some of the results on regional, seasonal and annual fluctuations of trawl catch presented at the SEAFDEC Seminar.

Table I. Number of trawl hauls by area and by year

Area	Year			
	1970	1971	1972	1973*
South China Sea	271	224	149	40
Straits of Malacca	—	24	24	7
North Andaman Sea	—	—	13	24
Total catch (ton)	47	50	40	21

*Up to the end of March.

Table II. Mean catch per hour by area and by year (kg)

Year	Area*						
	T	N	B	V	C	M	A
1970	159.9	154.5	149.4	—	80.1	—	—
1971	175.9	126.0	175.7	74.2	91.1	130.6	—
1972	176.8	120.0	154.5	—	—	170.5	361.0
1973**	99.4	—	—	—	—	170.5	398.2

* T: adjacent to Tioman Island, N: northern area of east coast of West Malaysia, B: north coast of Borneo, V: south coast of Vietnam, C: central part of south-western South China Sea, M: off Straits of Malacca, A: north Andaman Sea.

** Up to the end of March.

2.3 Precise estimation of fish catch by experimental trawling

Because of the limited facilities in carrying out a wide range survey an attempt was made to find out the minimum number of trawl hauls required for the precise estimation of fish abundance. The method for estimating the

minimum number of trawl hauls derived from the analysis of the data collected from an intensive survey in a block of half degree square (900 square miles) near Tioman Island was 900 found to be applicable to a wider and more extensive area without losing its generality. The details of this study were also presented at the SEAFDEC Seminar.

Table III. Species composition of trawl catch by area (%)

Year	Area	T	N	B	V	C	M	A*
1970				Apr. May				
1971		Apr. June Sept. Oct. Nov. Dec.	Apr. June	Oct.	Sept.	Apr. June	July Dec.	Dec.
1972		Jan. Oct.		Nov.			Feb.	Jan. Nov. Dec.
1973		Mar.						Jan.
	No. of hauls	207	28	114	39	34	47	165
	Fish name							
	Red snapper	22.4	24.9	21.6	19.2	10.3	7.0	1.6
	Bigeyed snapper	17.0	10.6	13.1	1.1	18.2	12.5	0.0
	Threadfin snapper		2.4	5.0	3.9	10.5	7.2	1.2
	Goat fish	12.9	6.3	5.4	4.4	6.9	9.6	1.0
	Trigger fish	8.2	8.1	3.6	0.9	9.9	10.5	0.0
	Jacks & scads	7.4	8.4	5.4	11.7	6.3	7.0	6.0
	Nakedhead sea bream	5.0	3.9	3.4	3.5	5.1	3.0	0.0
	Thicklip grunt	4.2	3.2	5.8	6.1	0.6	3.1	0.0
	White snapper	4.2	3.7	2.1	4.1	2.5	2.5	0.0
	Lizardfish	3.9	3.1	2.7	14.6	5.9	1.4	1.4
	Catfish	3.3	1.6	3.7	0.0	3.7	11.1	14.2
	Grouper	2.1	1.8	2.2	2.6	2.2	2.5	0.0
	Rabbitfish	0.2	0.3	0.0	0.2	0.4	7.4	0.0
	Butterfish	0.0	0.0	1.5	17.3	0.3	0.0	0.0
	Groaker	0.0	0.1	3.8	0.0	0.5	0.0	27.7
	Grunter	0.0	0.0	0.8	0.0	0.0	0.0	8.2
	Golden snapper	0.0	0.0	1.8	0.0	0.0	0.0	7.6
	Clupeoids	0.0	0.0	2.6	0.0	0.0	0.0	7.2
	Soldier fish	0.0	0.3	0.0	0.1	0.1	0.4	0.0
	Barracuda	0.4	6.2	0.0	0.0	0.0	0.0	0.2
	Seabream	0.0	0.0	0.0	1.7	0.0	0.0	0.5
	Sharks & rays	3.4	3.5	2.9	2.2	8.5	1.3	4.4
	Spanish mackerel	0.1	1.3	0.5	0.0	0.0	0.4	2.2
	Others	5.3	10.3	12.0	6.4	8.1	13.1	16.6

*including results obtained by training vessels PAKNAM of Training Department (SEAFDEC) of Singapore-FAO/UNDP Fisheries Training Centre.

2.4 Species composition in catch

Considerable differences in species compositions in catch in different areas are shown in Table III. From the calculated community similarity index $C\lambda$ a remarkable difference of community in the South China Sea was recognised between area V and the other areas while higher similarity was seen between areas T and C, and B

and C. As the species composition in catch is affected not only by the difference in locality but also in depth, season and mode of distribution, studies on these factors have also been carried out. Tables IV and V show the results obtained from fishing operation in the areas bordering the coastal and offshore waters. Although these areas (a, b & c) were remarkable suggesting the influence

of coastal condition, different bottom features and depth.

Red snappers and bigeye snappers were the two most dominant groups of species occupying approximately 30 to 40% of trawl catch in the South China Sea, and were invariably found together in the same catch. However, the percentage of catch for either fish was different from haul to haul. Analysis of their catch and distribution shows that they form overlapping fish schools, the structures of which have also been studied mathematically.

Shrimp trawling surveys in international waters were also carried out but owing to shortage of information analysis has not been made.

3. BOTTOM LONGLINE AND VERTICAL HANDLINE OPERATIONS

For the purpose of developing and exploiting demersal fisheries resources in untrawlable fishing grounds the Research Department carried out some preliminary bottom longline and vertical handline fishing surveys in the South China Sea and Andaman Sea. The results obtained are summarised in Table VI.

3.1 Bottom Longline

While the data collected by CHANGI were insufficient to draw any conclusion, communications with commercial bottom longliners suggested that the local type of bottom longline gave a better catch than the Japanese type although the catch of both types of gear was poor. Experimental results on bait preference showed that the overall catch by each type of bait was not significantly different although it appears that individual species had different bait preference.

Table VI. Summary of bottom long line and handline operations

Year	Area	Near Gulf of Thailand	Off Sarawak	West coast of Thailand
Month/Year		June 1972	Sept. 1972	Feb. 1973
Type of line		longline	longline	handline
Total no. of units used		200	224	20
No. of operations		11	9	39 hr. 30 min.
Total catch (kg)		558.6	676.4	1,725.1
Fish name				
Red snapper		26.5%	25.7%	0.2%
White snapper		27.6	18.9	57.2
Sea bream		0	0.1	20.9
Trevally		2.9	—	10.8
Grouper		0.9	0.1	4.8
Catfish		23.6	20.4	—
Shark		8.1	26.3	—
Pigface fish		—	—	3.9
Others		10.4	8.5	2.1

3.2 Vertical handline

The interesting results obtained by CHANGI and three other Japanese research vessels on vertical handline operations in the South China Sea and the Andaman Sea are discussed in greater detail in another paper presented

at the SEAFDEC Seminar. However, it may be of interest to know that fish caught by vertical longline have high market value, especially the white snapper (*Pristipomoides* spp.) which constitutes about 60% of the total catch. As the fishing grounds are not fully developed and exploited attempts are being made by the Research Department to carry out further research in the South China Sea and Andaman Sea so that this method of fishing can be established for the benefit of the region.

4. TUNA LONG LINE OPERATION

Two tuna longline operations were carried out, one in the Indian Ocean and the other in the South China Sea. Owing to insufficient data no analysis has been made.

5. FISHERIES BIOLOGY OF ECONOMICALLY IMPORTANT SPECIES

Collection of biological and ecological data on economically important species is also an important part of the Department's research programme. Size frequencies, seasonal succession and distribution of these species were analyzed to estimate their age and growth. Gonadal development, fecundity as well as the feeding habits of fish selected from various trophic levels were also studied.

6. OCEANOGRAPHIC OBSERVATIONS

Surveys have been carried out in the South China Sea for the observation of physico-chemical characteristics of sea water, nutrient sources, bottom feature and topography, plankton biomass, fish eggs and larvae as well as benthic fauna. The number of oceanographic stations occupied by CHANGI is shown in Table VII.

Table VII. Number of oceanographic observation stations by area and by year.

Year	Area	South China Sea	Straits of Malacca	Indian Ocean	Andaman Sea
1970		57	—	—	—
1971		75	12	6	—
1972		130	10	—	6
1973*		3	15	—	7

*Up to the end of April.

The results showed that physico-chemical characteristics of sea water were largely affected by the monsoon currents. Temperature-salinity diagrams and the depth of thermocline indicated the different characteristics of the water masses in the two monsoons. Differences between coastal and offshore waters were also recognized by the analysis of T-S diagrams.

Analysis of mud samples showed close relationship between bottom feature and types of current. The relationship between bottom conditions and distribution of benthic animals such as the shovel-nosed lobsters and large sponges was also studied.

Table IV. Difference in species composition in adjoining areas a, b and c off Sarawak in November 1972.

Area	a	b	c
Depth (m)	12	7	9
Fish name			
Grouper	1.2	0.5	1.0
Red snapper	18.8	11.7	9.6
Thicklip grunt	3.1	—	—
Lizardfish	1.1	1.2	8.7
Triggerfish	0.1	1.3	0.1
Threadfish snapper	1.3	0.6	2.4
Catfish	3.0	15.8	14.8
Caranx & scad	14.5	13.6	7.5
Bigeyed snapper	—	2.1	1.8
Shark & ray	7.7	10.5	0.6
Clupeoid	2.1	12.2	29.0
Jewfish	11.2	14.8	13.6
Golden snapper	13.2	0.6	1.2
Others	22.7	15.1	9.7

Table V. Difference in species composition (%) in the north Andaman Sea according to the depth, Dec. 1972.

Depth (m)	37-48	50-80
No. of hauls	9	4
Red snapper	1.0 %	14.7 %
Nakehead sea bream	0	1.4
Grouper	—	1.0
White snapper	0	1.6
Lizardfish	4.8	11.6
Goatfish	0.3	10.4
Catfish	6.1	3.3
Threadfin snapper	2.1	6.6
Caranx & scad	7.4	31.8
Clupeoids	13.7	0
Bigeyed snapper	0	1.5
Jewfish	48.1	0
White pomfret	7.8	0
Shark & ray	3.9	9.1
Others	4.8	7.0

With a few exceptions the plankton biomass was found to be high in the coastal area and decreased towards the open sea. The individuals of copepods and chaetognaths per cubic meter of water showed remarkable decrease in number from coastal water to the open sea. The variability of plankton catches and the diurnal vertical migration of zooplankton were studied. Taxonomical and ecological studies on fish eggs and larvae were also conducted. So far 137 species of fish larvae were identified to the generic and/or specific levels. The survey of distribution and seasonal fluctuation of fish eggs and larvae are being continued.

The results of sea water analysis showed that phos-

phate-phosphorus ($PO_4\text{-P}$) content increased towards deeper water. Comparative studies of $PO_4\text{-P}$ values and salinity suggest that nutrients in the coastal waters came from freshwater discharge of rivers, while the origin of high $PO_4\text{-P}$ value at some areas in the open sea was unknown.

The dissolved oxygen of the water was also examined. Generally, the dissolved oxygen was high in the upper water layers and decreased with depth. However, oxygen maximum was recorded at depths of 20–80 m. and not at the surface. This suggests that intense solar radiation at the surface reduces the photosynthetic activities of phytoplankton.

The analysis of echo-sounding records confirmed that the scattering layer occurred within the depth range of thermocline detected by bathythermograph, and the value of plankton biomass at the scattering layer was higher than that obtained in waters outside the layer. It was also observed from the echograms that fish schools dispersed at the vicinity of the scattering layer.

Simultaneous oceanographic observations showed that good catches were located near the bordering area where cold water mass from deeper layers converged with warm surface water. However, the locations of good fishing grounds were found to fluctuate with seasonal changes in oceanographic conditions.

From the studies of echograms it appears that the echo-sounder is an important device not only for locating fish schools and scattering layers but also for the studies of environmental factors, such as current rip, boundary zone and upwelling, which may be important for the formation of good fishing grounds.

7. FUTURE PLAN

The results of the Department's research activities, as summarised above, are contained in 15 papers (Appendix I) presented at the SEAFDEC Technical Seminar on fisheries resources in the South China Sea and its adjacent waters. From these, it can be seen that the fisheries resources survey and other research activities of the Department were mainly confined to trawl fishing in the South China Sea. However, the Department extended its activities recently to other adjacent waters and to investigate various methods of exploiting demersal fisheries resources other than by trawling.

The trawl fishing survey in the South China Sea will now be limited to known fishing grounds where economic feasibility studies will be carried out in conjunction with the types and sizes of vessels from Member Countries presently operating in the region. Trawl survey on demersal resources in the Andaman Sea and shrimp resources in international waters will be intensified. In untrawlable fishing grounds the use of bottom longline, vertical handline, bottom gill-net and drift gill-net will be investigated.

Apart from the studies on demersal fisheries resources the Department will be conducting systematic hydro-acoustic surveys after the installation of a sonar in July 1973. This is in preparation for the investigation of pelagic fisheries resources in the SEAFDEC area. A

smaller research vessel is therefore necessary to carry out investigations on pelagic and coastal fisheries resources.

With these in mind it is hoped that SEAFDEC can contribute positively to the development of fisheries in the region.

Appendix I

Papers presented at the Technical Seminar on South China Sea Fisheries Resources

1. Results of the experimental trawl fishing in the South China Sea by R/V CHANGI in the years 1970 to 1972.
2. Trawl fishing grounds in North Andaman Sea.
3. Demersal fish resources in untrawlable waters, viewed through vertical-line fishing.
4. Biological study of red snapper, *Lutjanus sanguineus*.
5. Studies on the feeding habits of red snapper, *Lutjanus sanguineus* and *L. sebae*.
6. A study of the catch data of the JURONG in the South China Sea in 1971 and 1972.

7. A rational survey method for evaluation of trawl fishing ground.
8. Fish school structure of red snapper and bigeye snapper in the South China Sea.
9. Behaviour of the warm-water mass along the east coast of the Malay Peninsula.
10. Fishing condition and its oceanographic interpretation in bottom longline fishing grounds.
11. Preliminary observation on the distribution and catch of the shovel-nosed lobster, *Thenus orientalis* Lund in South China Sea.
12. Some consideration on the relationship between environmental factors and the distribution of fisheries resources in the South China Sea and the Andaman Sea.
13. Brief note on the relationship of scattering layer and some hydro-biological factors.
14. Records of echo-sounder tracing as guide to locate and evaluate good fishing grounds.
15. Preliminary report on the distribution of chaetognaths in the southern part of the South China Sea.

SEAFDEC/SCS. 73: S-25

Harvesting of Marine Resources in the Philippines

by

Efren Ed. C. Flores
University of the Philippines
College of Fisheries
Diliman, Quezon City
Philippines

Abstract

The production from commercial and municipal fishing are presented for a period of 10 years showing a continuous increase. The commercial fishing production is broken down into production by major fishing grounds for a closer evaluation.

The trend by type of fisheries for the same period is also presented. Purse seine and trawl fisheries show advancement with increase in production and number of fishing vessels in operation.

1. PRODUCTION FROM COMMERCIAL AND MUNICIPAL FISHING

Commercial fishing refers to fishing operations conducted on board fishing vessels more than 3 tons gross licensed by the Bureau of Fisheries. For municipal fishing, these are fishing operations mostly done in municipal waters with or without the use of a vessel 3 tons gross or below.

Fig.1 shows the trend of fish production from commercial and municipal fishing for a period of 10 years (1962-1971)*. The trend is a continuous increase of production for both municipal and commercial fishing.

* All figures were taken from the Fisheries Statistics, Bureau of Fisheries, 1962 to 1971.

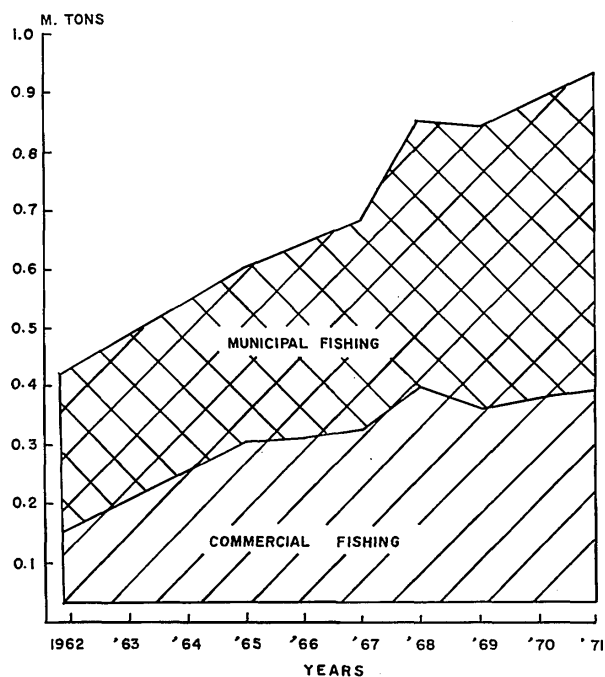

Fig. 1

For 1962, with a combined production of 0.42 M tons, municipal fishing showed a production 0.1 M tons more than that of commercial fishing. The following years showed the increase of commercial fishing production and then in 1965, both had the same production of 0.3 M tons each. The production continued its increase and for 1971, the total production was 0.93 M tons with 0.54 M tons for municipal fishing and 0.38 M tons for commercial fishing.

Even with the increase of fish production over the period, this has not met the fish consumption requirement of the country. For 1970 there was still a production deficiency of 26%. This shows that the rate of increase in production is not coping up with the rate of increase in fish consumption.

2. PRODUCTION BY MAJOR FISHING GROUNDS

Production of municipal fishing by fishing grounds could not be presented here because estimates of production were derived from previous years trend. Only with commercial fishing could a detailed examination of production by fishing grounds be made based on figures gathered by the Economics and Statistics Section of the Bureau of Fisheries. The trend of production by major fishing grounds is shown in Fig. 2.

2.1 Sulu Sea (Palawan waters)

The production increased tremendously by 725% from 1972 with 32,298 tons to 1971 with 235,810 tons. This increase is mainly attributed to the increasing number of purse seine fishing vessels operating in the area (See Fig.5).

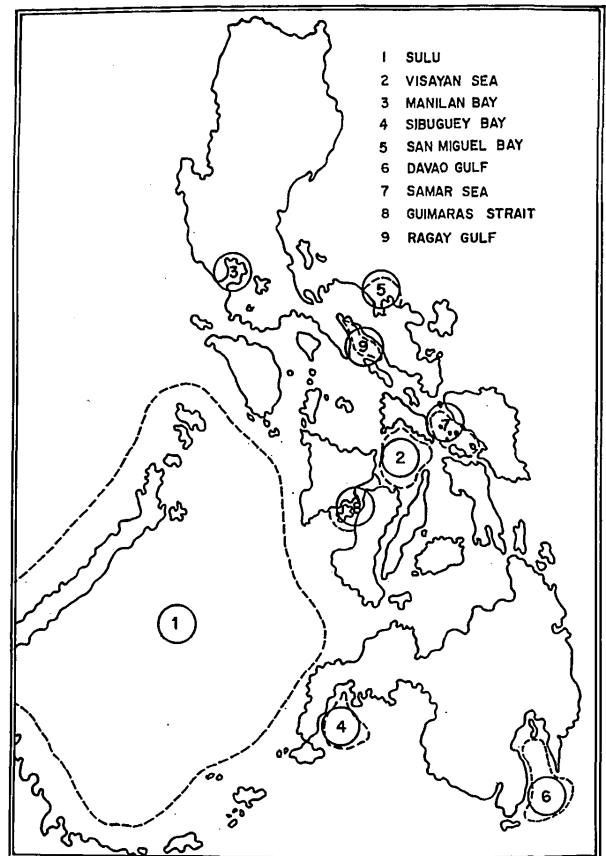

Fig. 3

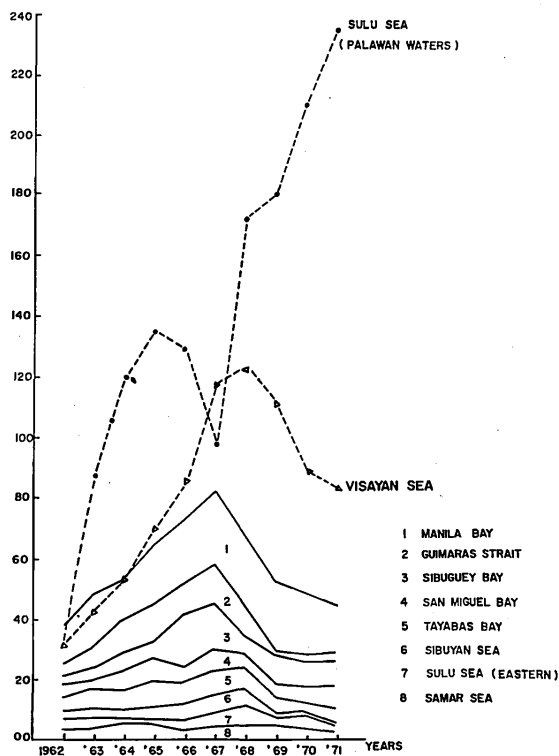

Fig. 2

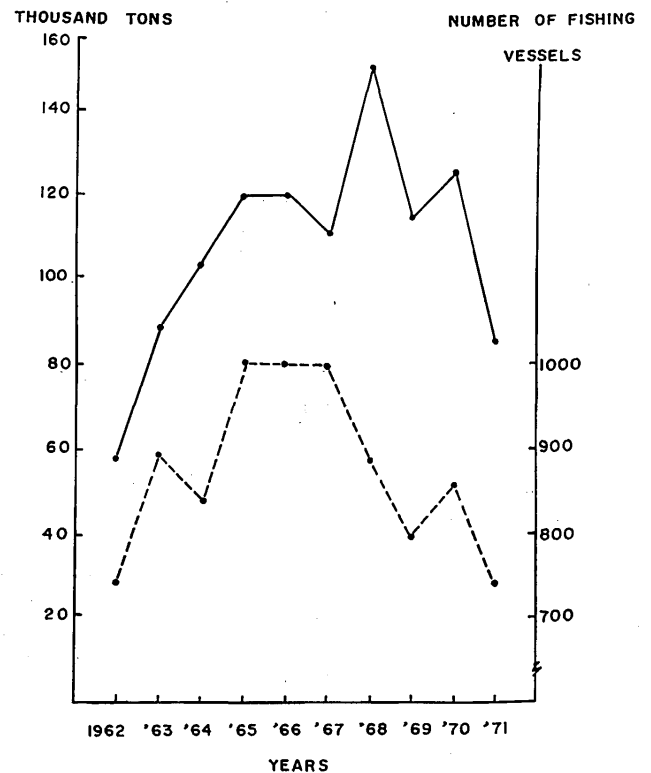

Fig. 4

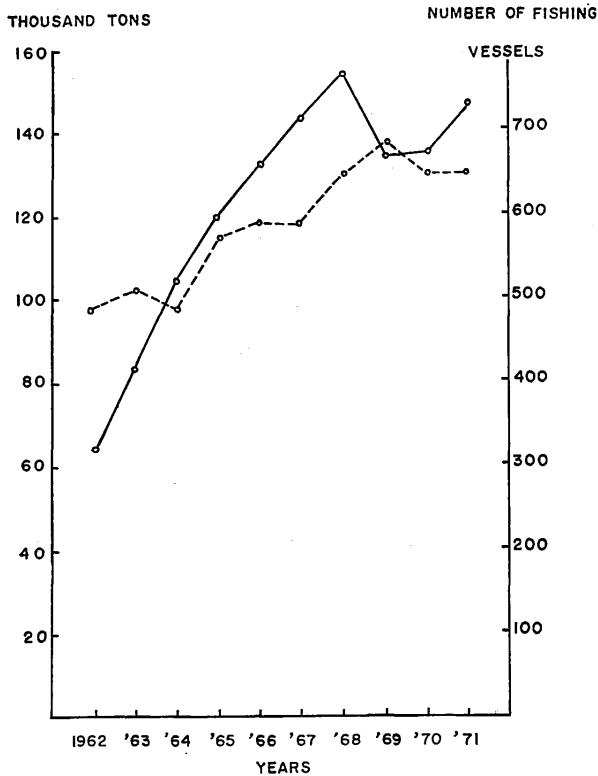

Fig. 5

2.2 Visayan Sea

A gradual increase in production is observed from 1962 with 32,530 tons to 1968 with 124,164 tons, or an increase of 480%. The major fishing gear being operated in the Visayan Sea is otter trawl. The production of the trawl fisheries (see Fig. 4) shows the same pattern of general increase. However, the production of Visayan Sea made a decrease during the succeeding years. Then in 1971, the production went down to the level of 1966 production. The same trend is also observed for trawl fisheries resulting to the reduction of trawl fishing vessels in operation. This creates a problem for fisheries management.

2.3 Manila Bay

There is not much fluctuation in the volume of production for the period with an average of 18,993 tons. The principal fishing gear operated in Manila Bay are Bag net, Purse seine and Otter trawl.

2.4 Giumaras Strait, Sibuguey Bay, San Miguel Bay, Tayabas Bay, Sibuyan Sea, Sulu Sea (Eastern) and Samar Sea

The following fishing grounds do not present any noticeable increase in production but rather a decrease in some areas. The total production of these fishing grounds including Manila Bay is less than the sole production of the Visayab Sea.

Fig. 3 shows the location of the major fishing grounds in the Philippines and numbered according to their respective production based on the 1970 statistics.

3. TREND BY TYPE OF FISHERIES

3.1 Trawl fisheries

From 1962 to 1968, the production has increased by 240% with the increase in number of fishing vessels operated (see Fig. 4). There is a decrease for 1969–1970 period but picking up again in the following year. In 1971, a total of 652 units operated and harvested 146,359 tons.

3.2 Purse seine fishery

This is one fishery that has shown a tremendous increase in production from 953 tons in 1962 to 117,694 tons in 1971 (see Fig. 5). The marked progress in this fishery was brought about by the increasing number of purse seine fishing vessels most of which were acquired by the private sector from Japan as used fishing vessels at give away prices. These vessels were then brought to the Philippines including synthetic fishing nets and fish finders and remodeled for purse seine operation by installing power blocks. In 1971, a total of 265 units operated.

3.3 Bag net fishery

The production of this fishery has had an increase from 1962 to 1968 but from then on followed a downward trend (see Fig. 6). The same pattern is followed by the number of units operated.

The same group of species are being caught by bag net and purse seine fisheries. With the latter producing a greater volume of catch than the former, the present trend is for bag net operations to shift to purse seine fishing. A total of 85,861 tons was harvested by 743 units in 1971.

3.4 Round haul seine fishery

The trend of production for this fishery has not been good (see Fig. 7). From 1962 to 1971 the production fell with the number of units in operation following the same pattern. The replacement of round haul seine net by a

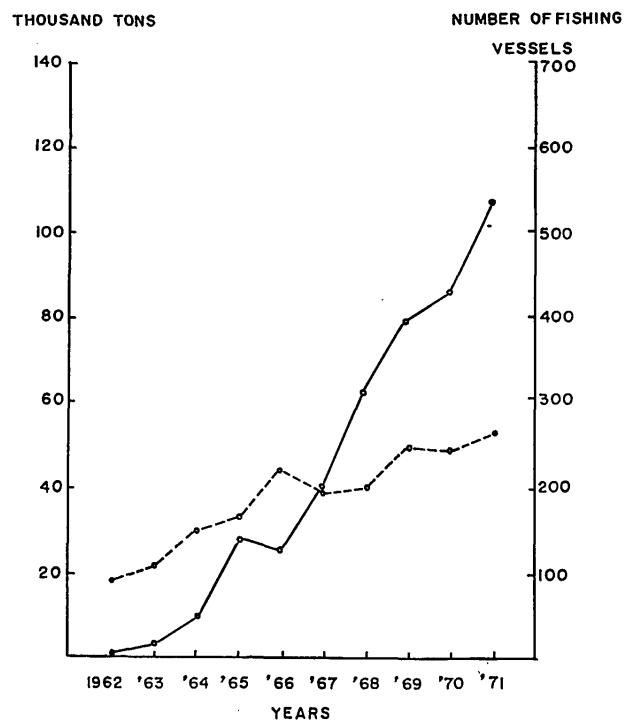

Fig. 6

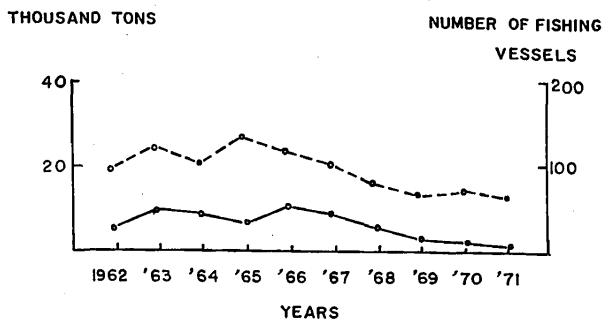
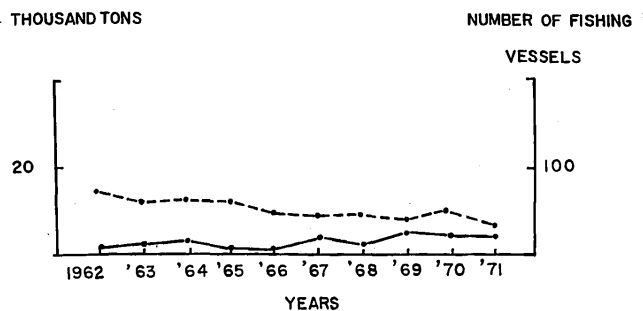
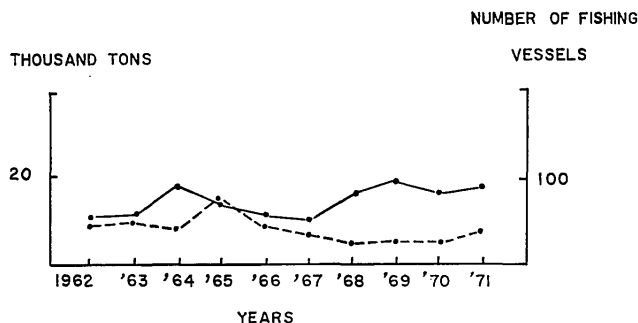

Fig. 7



(A) BEACH SEINE



(C) MURO - AMI

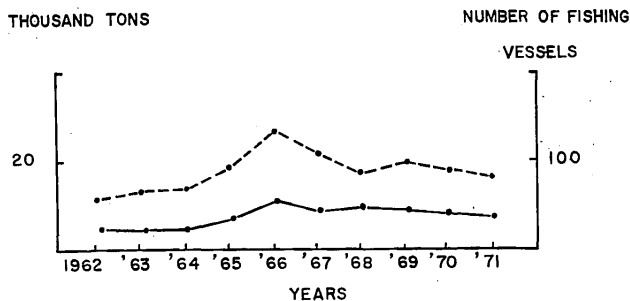

(B) HOOK AND LINE

Fig. 8

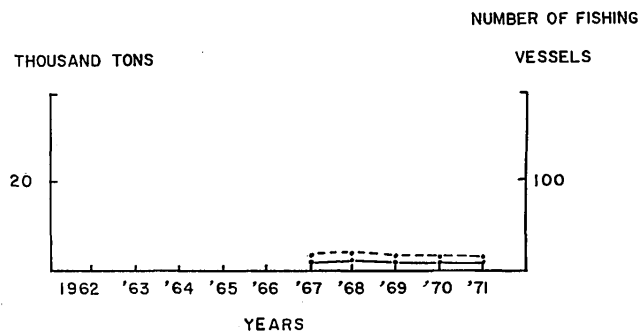

(D) TUNA LONGLINE

Fig. 8

small purse seine net is being considered to save the operators of the former gear. For 1971, 61 units operated harvesting 2,446 tons.

3.5 Beach seine fishery, Hook and line fishery, Muro-Ami fishery and Tuna long line fishery

These fisheries have generally shown a constant production from 1962 to 1971 (see Fig. 8). These fisheries may be termed as "stagnant fisheries". The records from 1967 to 1971 do not show any growth in the production of tuna with only 200 tons in 1971 and 5 units operating. Most Philippine tuna is being harvested by hook and line fishery which is operated in coastal waters.

SEAFDEC/SCS.73: S-27

Problems Other than Fisheries Resources in the South China Sea Area

by

Tadashi Yamamoto
FAO Fishery Statistician

INTRODUCTION

Problems other than fisheries resources in the South China Sea Area can be broadly classified into two:

- (1) those relating to the nature of the fishing industry; and
- (2) those relating to fisheries institution to support

the fishing industry.

Attempt is made in the present paper to clarify the nature of these problems and to give some guide lines for solving these problems.

1. PROBLEMS RELATING TO THE FISHING INDUSTRY

1.1 Economic Structure of the Fisheries

In Asia, fishing establishments may be broadly classified into two categories; one the **fishing household** which engages in small scale fishing mainly with its own family members and the other the **fishing enterprise** which engages in large scale fishing mainly with enterprise employed fishing labourers exploiting demersal and pelagic resources in off-shore waters.

One of the important roles of a fishing census is to clarify such an economic structure of a fishery. Many Asian countries have participated in the 1970 Fishery Census which was recommended by the 11th Session of Indo - Pacific Fisheries Council (IPFC). However, as with the exception of Thailand the Fishery Census is still under progress no comparable data are available. Therefore, as shown in the attached Table the number of fishing households and fishing enterprises was estimated based on data currently available so as to give a very crude idea on the economic structure of the fishery in the area.

As seen in the attached Table there are some 660 thousand fishing establishments in the area, the majority of which are fishing households being 98.7% of the total. Only some 7,500 or 1.5% of the total are fishing enterprises, which operate in off-shore waters. In considering the development of fishery in the area this fact may well have to be kept in mind. At this moment, how far each of these two different categories of fishing establishments is contributing to the total national fisheries production is still not clearly known due to the lack of statistical data available. However, according to the results of annual sample survey on marine fisheries in Thailand fishing enterprises which are only some 3,000 in number produce nearly 80% of the total marine catch, whereas fishing households which account for 38,000 contribute only 20% to the total.

From the above illustration one can well imagine how a great discrepancy of fishery income has appeared between fishing households and fishing enterprises. In planning a fishery development programme either at national or inter-regional level a clear recognition on the economic structure of a fishery has to be made, since the nature of problems encountered greatly differs between fishing households and fishing enterprises. Usually the former suffers from the low productivity of fishery which will, in turn, result in poor livelihood of in-shore fishermen. Whereas, the latter has been bothered as to how to locate a better fishing ground to raise its fishing efficiency although it may have a problem of finding capital sources to expand the size of its fishing enterprise.

In developing a fishery in the area, equal attention should be paid to these different sub-sector of the fishery in the area. One must be aware that so far many government measures as well as bilateral or multi-lateral aid

projects have laid a great emphasis on the development of fishing enterprises ignoring the problem of fishing households.

1.2 Fishing Establishment

A fishing establishment is an economic body which has an intention of doing fishing business regardless of whether it is a fishing household or fishing enterprise. Many governments have established a programme of encouraging their fishing activities by introducing a new fishing gear, a newly designed fishing boat, a fishing credit system, etc. However, for implementing such a fishery development programme, many governments have met a severe difficulty due to the absence of fishermen's organization which is only the media to communicate between the government and fishermen. Without the help of fishermen's organizations the government has no way of doing anything. At present fishermen's organizations which are capable to do something for the benefit of fishermen are available only in parts of Malaysia and Indonesia.

1.3 Fishing Boat

A fishing boat is the most important and indispensable production means of fishermen. As a fishery in the area is fundamentally formulated on the basis of in-shore fisheries, the majority of fishing boats are either non-powered boats of indigeneous nature or small powered boats. This has naturally led to low productivity of in-shore fisheries, which in turn has resulted in a poor income of in-shore fishermen.

It has become a common rule that the mechanization of non-powered boat and/or the enlargement of the size of small-powered boat will play a greater role in improving the productivity of in-shore fisheries. However, in-shore fishermen are generally poor and hence cannot afford enough own money to do so. Therefore, a real problem in relation to a fishing boat lies in the procurement of capital for acquiring a boat engine or a larger boat rather than the pure technical improvement of a present fishing boat itself.

In considering the mechanization of a non-powered boat and the enlargement of a small powered boat there are two factors which have to be taken into account. One is whether fisheries resources which can be further exploited are available or not. The other is whether the mechanization of a non-powered boat or the enlargement of a small powered boat in size is economically beneficial or not. Such a study has hardly been done so far.

There might be some technical problems on the improvement of a large fishing boat in terms of e.g. cruising speed, fishing efficiency, etc. However, such technical problems could be mostly solved with the effort of the entrepreneurs themselves, since the business of off-shore fisheries cannot be in existence without having an efficient boat.

1.4 Fishing Gear and Fishing Technique

It is often said that fishing gears in use by in-shore fishermen are rather traditional and hence are in need of improvement. This argument may be, to some extent, true in certain areas. However, in many instances the traditional fishing gears have been developed for many centuries

so as to fit to the local condition of fishing grounds and the behaviors of fishes living in those areas. Therefore unless those gears are extremely primitive, there may not be much to improve.

1.5 Fishermen

In operating any fishing a fisherman is one of the elements together with fishing boat and fishing gears. It is also often said that in order to develop a fishery local fishermen have to be trained. It is true that a facility to train local fishermen is seldom available in the area. However, a question arises as to what type of training should be given to local fishermen. One must realize that the present training to fishermen under national or bilateral or multilateral project has laid so much emphasis on trawl and long line fishing technics.

1.6 Fisheries Infra-structure

Fisheries infra-structure, such as fishing harbour, fish marketing facility, ice-making factory, cold storage, boat and engine workshop, fish transportation facilities, etc. is the most important factor in the development of any fishery. Without these facilities no fisheries development could be realized. However, at present this matter has been greatly left behind in most countries of the area. As a result, a harbour that can be called a fishing harbour with various facilities as described above can be hardly seen in the area.

Any government in the area has formulated a plan of developing off-shore and deep-sea fisheries as a part of the national economic development programme. However, a plan of developing fisheries infrastructure is seldom seen in those plans. Fundamentally, the development of fisheries infra-structure should be considered in parallel with that of fisheries themselves. Hence, an important thing to note is that a fishing business is a concern of an individual who intends to do a fishing, whereas fisheries infra-structure facilities are a concern of all fishermen. Hence, the development of fisheries infra-structural facilities has to be done with the responsibility of the government.

of the government.

1.7 Fish Preservation and Processing

Fish is perishable and hence to keep its freshness until it reaches consumers has to be a great concern of fishermen, middlemen and consumers. This matter is particularly important from the viewpoint of fish producer, since a good price cannot be realized unless the freshness of fish is well maintained. So far the governments in the area have hardly involved in this problem.

The traditional methods of fish processing in the area are mainly sun-drying, salting and fermenting. It seems that there are not much to do in this area although the method of fish processing is primitive, since local consumers have been accustomed to take them and cannot afford purchasing more sophisticated fish commodities which are generally costly. On the other hand, recently the freezing of high quality fish like shrimp, cuttlefish, Spanish mackerel, etc. have become popular for export purpose. However, due to the absence of quality control by the government the producers have often suffered from a claim from importers. Therefore, the establishment of the government financed quality inspection system is

likely to be urgent.

As mentioned earlier, the production of trash fish in huge quantity seems to be fatal to the fishery in the area. Therefore, if a trawl fishery has to be further developed in the area, a study on how to make best use of this trash fish may have to be considered from the viewpoint of raising its economic value. There must be a fishery product made of trash fish other than fish manure, and fish meal, by which the present price of trash fish can be raised.

2. PROBLEMS RELATING TO FISHERIES INSTITUTION TO SUPPORT FISHING INDUSTRY

2.1 General

Fisheries institutions are defined as all types of institutions which will directly or indirectly render various services to fishermen or the fishing industry, and hence it covers not only national office of fisheries such as Dept. of Fisheries, Fisheries Commission, Fishery Agency etc. but also fishermen's cooperative society and its federation, various fisheries credit system, fisheries educational institutions, etc.

Fisheries institutions which are currently in existence in the area are, in many instances, those which were established during a colonial time. In spite of the fact that the pattern of a fishing industry in the area has been greatly changed in the past two or three decades, a very little improvement has been made on these institutions. As a result, the present status of fisheries institutions in the area is, in many cases, inadequate and weak.

Countries in the area have received a variety of technical assistance through either bilateral or multilateral aids. However, many of them are basically those in the field of natural science, such as fishing techniques, fish culture, fishery biology, fish processing, etc. In the field of fisheries institution the only exception may be two FAO Training Centers on "Fish marketing" and "Fishery cooperative society" which were held in Hongkong in 1954 and Sydney in 1957 respectively.

2.2 Fisheries Legislation

Fishery legislation is a general name of fishery law, fishery act, fishery registration, etc. In most countries the fisheries legislation which was promulgated during a colonial time is still in force without any substantial change in spite of a great change appeared in its fishery. Generally, such a fishery legislation will define the overall structure of fisheries institutions in a country and hence this matter is specifically dealt with at first.

Pertinent defects which are commonly found are summarized as follows:

1. The fishery legislation has been worked out mainly to secure the source of a budget for maintaining a national office of fisheries such as Dept. of Fisheries, Fisheries Div., Fisheries Commission, etc., although the legislation gives, to some extent, some regulations with regard to the conservation of fisheries resources. As a result, various taxes, such as fishing gear registration fee, fishing boat registration fee, fishermen's fee, fish caught fee, etc. are being imposed on the fishing industry.
2. Since the fishery legislation was worked out either

when inland fishery was predominant rather than marine fishery or when only in-shore fisheries were in existence, provisions with regard to the management of off-shore fisheries and those to eliminate the conflict between in-shore and off-shore fisheries and hence to protect in-shore fisheries are lacking or inadequate.

An important thing to note is that the present fishery legislation has often become a severe burden to make a balanced development of a fishing industry. Further more, in certain cases, the present fisheries legislation cannot cope with the management of international fisheries resources which has become necessary to some extent in the area, since off-shore fisheries are very loosely treated in it.

The foregoing reveals that now is the most appropriate time to review thoroughly the current status of fisheries legislations and to revise them so as to cope with the present need.

2.3 National Office of Fisheries (Dept. of Fisheries, Directorate of Fisheries, Fisheries Commission, etc.)

Every government in the area has a national office of fisheries which is normally under the Ministry of Agriculture. The real role of a national office of fisheries is to render various services to the fishing industry, by which a well balanced development of a fishery is achieved. However, the current function of a national fisheries office is, in many instances, heavily biased to either law enforcement or fishery biological research. As a result, the national fisheries offices are often considered as an enemy by fishermen, and hence there are a very few linkages between the national office of fisheries and the fishing industry.

Some pertinent points with respect to the current status of a national office of fisheries are given below:

A. Fisheries Development Planning and Fishery Statistics

Every government has a fishery development programme which has been worked out as a component of its national socio-economic development programme. Basically, such a fishery development programme may have to be prepared with an initiative of fisheries resources. However, owing to non-existence of fishery economist and absence or inadequacy of fishery statistics such a fisheries development programme has been poorly prepared, and hence it gives, in many instances, only several targets without specifying any measures to achieve them.

The development of national fishery statistical system has been largely burdened by

1. the present fisheries legislation which is of more law enforcement nature and
2. lack or inadequacy of fishermen's organization, the detail of which will be given below to some extent.

B. Fisheries License System

Based on the present fisheries legislation various fisheries licenses are issued to fishermen under the name of fishing gear registrations, fishing boat registration, etc. It is quite important to note that the major objective of issuing these fisheries licenses is to grasp the number and nature of objectives of fisheries administration, for which the national office of fisheries will try to render its

services.

However, the situation is entirely reverse, and during the course of issuing these licenses the focus is given to the collection of tax from fishermen. Naturally due to an evasive attitude of fishermen for tax payment this fact has resulted in the incompleteness of the record of fisheries license issued, which has, in turn, caused a difficulty of using these license records as a frame for the designing of various fishery statistical surveys.

As the present fisheries legislation has been visualized mainly aiming at collecting taxes from fishermen, this has affected the overall work of a national office of fisheries. In a certain country this work has occupied a tremendous part of the total work of the national office of fisheries inhibiting the expansion of other useful services to be rendered to a fishery.

C. Public Investment for Fisheries Infra-Structure

Mention has already been made somewhere in Section 1. that the provision of fisheries infra-structural facilities is the pre-requisite for the development of any fishery. A fisherman acquires a fishing boat and a fishing gear at his own responsibility. However, owing to the public nature of the fisheries infra-structure it is considered that only the government is the appropriate organization to take an active role on this matter.

It must be aware that the improvement of fishery infra-structure is something like that of irrigation system in agriculture. It is a wellknown fact that without the improvement of irrigation system agricultural production cannot be increased. Similarly, without the improvement of fisheries infra-structure a fishery as a whole cannot be properly developed. This is particularly true for the development of off-shore fisheries.

So far the national offices of fisheries in the area have hardly involved in this matter mainly due to the lack of financial support. However, it has become a common practice in many countries that in drafting an annual budget as a whole a good amount of budget for public investment is set aside at first to relax the unemployment problem of a country as a whole. Therefore there is a good possibility of sharing a part of such a budget for the development of fisheries infra-structural facilities. Furthermore, the construction of fishing harbour, fish market facilities, cold storage, etc. is considered to be the most appropriate project for a loan application to ADB or IBRD.

D. Fisheries Research

Fisheries research has to be done from the viewpoint of both biological and economic aspects. However, in most countries of the area the fishery research is extremely biased to fishery biology ignoring the study of fishery economy. It is, therefore, often found that the study of fisheries biology is done for the good of fisheries biology without reference to its implication with the fishing industry. Hence, there seems to be a keen need to make a thorough and careful review on the nature of all ongoing fisheries researches from the viewpoint of their usefulness to the fishing industries.

In viewing the current status of fisheries research

activities as a whole there is also a need to examine whether or not the present scale of fisheries research activities is well balanced to the other works of a national office of fisheries. In certain countries the fishery research is extremely ill treated perhaps because of the shortage of the budget, whereas in other countries the national office of fisheries has become as if it is a Department of Fisheries Research.

2.4 Fishermen's organization and Fishery Credit System

Fishermen's organization which is ideally to be organized in the form of fisheries cooperative society has been least developed in the area. Fundamentally, such a fishermen's organization is formulated for the benefit of fishermen by selling the catch caught by the members, by purchasing fishing materials for the members at cheaper price, by granting a credit to the members at a reasonable rate of interest, etc. However, such a fishermen's organization is also used as the most appropriate channel to render the government's services to fishermen. At present, the majority of fishermen are not organized into any type of fishermen's organization, and hence the government has no way of rendering its services to fishermen.

In many countries the matter of fishermen's organization has been dealt with by offices other than the office of fisheries. As such offices usually deal with not only fishermen's organization but also other organizations and furthermore a fishery is always considered less important comparing with other industries, the matter of fishermen's organization has been often overlooked.

Owing to a great difference in the nature of problems encountered it may be ideal to have a fishermen's organization for in-shore fisheries and off-shore fisheries separately. It may be also desirable that each of them have the responsibility for conserving fisheries resources.

2.5 Fishery Credit and Fishing Boat Insurance

For the development of a fishing industry a fishery credit system plays a key role, since fishermen usually do not keep enough saving for the acquirement of engine or larger boat. However, such a fishery credit system has also been poorly developed in the area. As a result, fishermen often make a loan with fish merchants. This practice naturally causes two disadvantages to fishermen; one is that the rate of interest for such a loan is usually very high, and the other that the price of fish is determined in favour of fish merchant who made a loan to fishermen.

In making a loan to fishermen the greatest burden is that fishermen usually do not have enough mortgage which causes a great risk to the creditor. The only way to solve this problem is to establish a fishing boat insurance scheme with the help of the government. In providing such a fishing boat insurance scheme the government usually provides a fund by which part of the premium to be paid by fishermen is subsidized. At present, such a fishing boat insurance scheme does not exist in any country of the area.

In considering fishery credit and fishing boat insurance scheme an advantage should be taken from IBRD, which recently started to give a loan to small farmers.

2.6 Fisheries Education

2.6.1 Fishery education for the fishing industry.

Undoubtedly, in countries of the area fisheries educational institutions at various levels are by and large lacking. However, so far no in-depth study has been made with regard to what kind of fisheries educational institution is required in view of the development of a fishery in the area. It may be logical that the type of fisheries educational institutions to be developed is determined taking into account a particular sub-sector of fishery in the area which definitely has a good potential for development. For example, coastal aquaculture seems to be one of the prospective subsectors in the fishery of the area. If so, a fishery educational institution for such a course would best serve to the development of coastal aqua-culture

2.6.2 Fishery education for the fisheries institution

The matter of fisheries education may have to be considered not only from the viewpoint of training fishermen who really involve in a fishery but also from the standpoint of strengthening the ability and competence of personnel who work in a national office of fisheries, a federation of fisheries cooperative society or an unit fisheries cooperative society, etc. Needless to say, they are key personnel who guide the development of fisheries as a whole. At present, the latter type of fisheries educational institution is virtually lacking in the area. As a result, in recruiting a government official to a national office of fisheries an applicant is, in most instances, sought among graduates who majored merely in zoology, biology or fishery biology. This fact has often misled the general direction of a national office of fisheries, since those officials who majored in zoology or biology are usually reluctant to change their subject even after they become government officials.

Attached Table

Number of Fishing Establishments in the Area (Estimate)¹⁾

	Total	No. of Fishing Households Engaged in In-shore Fisheries	No. of Fishing Enterprises Engaged in in Off-shore Fisheries
Total	660,400	652,900	7,500
(%)	(100.0)	(98.7)	(1.3)
Philippines	233,000	231,000	2,000
S. Vietnam	50,100	50,000	100
Republic Khmer	4,000	4,000	-
Thailand	41,000	38,000	3,000
W. Malaysia	25,000	23,000	2,000
E. Malaysia	5,000	4,800	200
Brunei	200	200	-
Singapore	2,000	1,900	100
Indonesia	300,100	300,000	100

- 1) All figures given in the table are estimates based on data currently available with the exception of those for Thailand
- 2) No. of fishing labourers households whose family members are simply employed by others as fishing labourers is not included.

Fisheries of Vietnam

by

Ha-Khac-Chu

Administrative Officer
Fishery Institute
Vietnam

Abstract

The fishery resources of Vietnam have not been neither rationally managed nor exploited up to the present time. Fisheries organizations both on the government side and in the private sector were first established in 1957. Since then, fishery production has increased annually. The total catch in 1972 was 677,000 MT and if the rate of increased production can be mentioned is expected to reach about 1 million MT by 1975.

With the gradual coming of peace, it can be expected for a variety of reasons that the fisheries of Vietnam will be expanded significantly and become a bigger contribution to our food supply as well as export production.

At present, there are 340,000 fishermen operating 95,000 wooden fishing boats of which 55,000 are mechanized. The marine coastal area is intensively exploited by small boats while 20 large steel trawlers recently have begun to fish offshore. A joint project (UNDP-FAO and government of Vietnam) survey in the South China Sea and the Gulf of Thailand was set up 3 years ago and should continue to operate for some time to come.

The inland fisheries, the production of which represents one sixth of the total annual catch, is carried out in rivers, streams and flooded areas in the Mekong delta and also by fish culture in fresh water and brackish water ponds and in floating cages in rivers. With improved methods of aquaculture the yield of fish ponds increases constantly.

With a rapid expansion of the commercial fisheries, and rapid increases in exports, which tend to be concentrated on a few high value species, there may be a danger of over-exploitation in one area or another. There is also a danger that investment in plants, fleets, and shore facilities may be improperly timed and inefficiently utilized. Therefore, a thorough basic study of the entire commercial fisheries is needed, and a well coordinated plan for investment and development made. Plans are now being made to accomplish this important objective.

PRESENT SITUATION

Geographically well located, with a coast-line of more than 2,000 km in length next to a gentle continental shelf of about 1,200,000 square kilometers, and with over 4,000 km of fresh water ways loaded with plankton, Vietnam is favoured with both marine and inland fisheries

resources. But the fisheries industry in Vietnam was completely neglected during foreign domination, and then severely damaged by a long ravaging war. In spite of our great effort devoted to the fisheries industry it may still remain underdeveloped by lack of proper and sufficient technical and financial aid. The war has been less damaging to the marine fishery and it is more progressive than the inland fishery.

Up to now, we have about:

340,000 fishermen, using all kinds of fishing gear including trawls, purse-seines, gillnets, long lines, etc....However their techniques need to be improved. 95,000 wooden fishing boats, among them only 55,000 are motor powered. Most of these fishing boats are small and operate in coastal waters.

20 steel trawlers all of less than 300 tons, are exploiting our offshore fishing grounds.

In 1972, our production rose up to some 677,700 tons of which 500,000 tons were marine fish

81,000 tons were fresh fish,

54,000 tons were shrimp, and

40,000 tons were shell fish, including molluscs and squid.

In the same year, our exportation of fish products to Laos, Thailand, Singapore, Hong Kong, Japan, France, West Germany, the United States, etc... reached about 6 million US\$. The products exported were mostly frozen shrimp, chilled and frozen fish fillets, fish sauce and derived ones.

I - MARINE FISHERIES

A - Offshore fisheries

With the aid of FAO-UNDP Vietnam has a project to survey the South China Sea and the Gulf of Thailand. The purpose of the survey is to:

Find and locate new fishing grounds.

Ascertain the possibilities of commercial trawl fishing for bottom fish off the coast of Vietnam

Help in the introduction of modern fishing gear and methods

Train Vietnamese cadres and fishermen

During the first phase of the project, the survey was made by two research boats, the Kyoshin Maru 52 (gross tonnage 312 T) and the Friendship (gross tonnage 114 T). Many data were collected to provide Vietnamese coast. However, we think that some of the component factors, such as location, importance of fish stocks and

species composition, and ages of various species etc... are of great importance for planning the future development of our fisheries.

A second phase of the project will help the achievement of:

Complementary prospect in the best fishing grounds spotted during the first phase to relocate and accurately estimate the extent of the concentrations of fish and shrimp and their potential productivity.

Improvement of the technical skill and the scientific expertise of the personnel of our Fisheries Institute.

Planning and supervision of the development of the future offshore fishing fleet, and related questions.

Training of officers and crewmembers (in various specialities) to be employed aboard the new vessels.

B. – Inshore fisheries

Most of our fishermen with their 50,000 powered fishing boats are exploiting the inshore fishing grounds. Fishermen now build larger boats, use all kinds of nets made of synthetic fibers particularly trawl nets, purse-seines, gillnets, and adopt efficient fishing techniques. Added efficiency may lead to over fishing and its detrimental effects. Fish catches are increasing every year and an improvement of the existing marketing system and methods of preservation is under experimentation. However the new marketing system meets the opposition of middle men and wholesale dealers. These men provide advance loans to fishermen and receive fish afterwards. They also sell fish on credit to the retailers in all markets throughout the country.

Shrimp catching is now considered a good business and many hundred fishing boats are trawling day and night to get shrimps for export. However the economies of this fishery needs to be examined in detail.

II – INLAND FISHERIES AND FISH CULTURE

With more than 4,000 km of water ways network and the south west region (Plain of Reeds) flooded every year by the Mekong River, the inland fisheries have a production that represents about 1/6 of the total catch of the country. Fishermen and farmers have also adopted effi-

ent methods to catch fish and now use small outboard boats to transport their catch to market faster.

Fish culture development, both in fresh and brackish water, is being enhanced. Government hatcheries distribute freely or sell at low price fingerlings to the farmers. Technical advice and appropriate loans to construct fish ponds for fish culture purpose have also been provided to fish farmers. In some areas where conditions are suitable (river, stream) fish rearing in floating cages is practiced. Thousands of acres of mangrove swamp and low lands in the south west are now under reclamation for Chanos chanos and shrimp culture.

III – FUTURE PROJECTS

The following measures are now under execution to increase production of both marine and inland fish:

To find new off-shore fishing grounds

To build off-shore fishing fleet

To improve the techniques of catching

To train fishermen and cadres

To provide sufficient (and in due time) loans to fishermen for better equipment

To gather data which can be used to protect aquatic fauna against overfishing at sea as well as in inland waters.

To dredge the river estuaries and build new landing facilities thus improving access to fishing ports.

To organize a chain of refrigeration facilities for fish preservation.

To improve the existing marketing system

To encourage local and foreign investment in fishing and related industries.

To assist fish culture technically and financially.

IV – DIFFICULTIES

In order to develop our fisheries rapidly, we have to overcome some difficulties, such as:

The lack of adequate fisheries technicians (fishery biologists, fishery technologists, fishery economists, statisticians, etc....)

The lack of statistical data and a basis investigation of the present situation and future prospects of our fisheries.

THE OTHERS

SEAFDEC/SCS.73: S-3

Preliminary Observations on the Utilisation of Pig-Dung Effluent for Fish Production

by

P.C. Seow and George Tay

Freshwater Fisheries Laboratory
Primary Production Department
Singapore

Abstract

In developing Singapore where agricultural land is

making way for urbanisation and industrialisation, carp culture is being looked upon from a new perspective. It is obvious that the wanton discharge of animal waste will

eventually result in polluted streams, reservoirs and coastal waters. In view of the above, preliminary investigations were carried out to evaluate the use of cess-pit effluent of pig dung for carp production. Initial results indicate that the carp pond can serve as a buffer zone where organic wastes can be cheaply and profitably removed, thereby minimising the subsequent pollution of our inland and coastal waters. However, further investigations are necessary to substantiate the use of carp ponds not only for fish production but also to serve as a reservoir for the biological reduction of organic pollutants.

INTRODUCTION

The process of industrial development in the island Republic of Singapore has brought about some changes inland utilisation. As more land is gradually developed for industrial purposes, agricultural activities decreased on a corresponding scale. Hence the various forms of such activities must be intensified for maximum land utilisation.

Pig rearing has been one of the main farming activities in Singapore. For the past decades before urbanisation, animal waste from such activities were washed and drained into streams directly or into ponds for carp production before discharging into streams. The hazards associated with this traditional method of mixed farming of fish and pigs are obvious. The unregulated discharge of pig washings usually results in over-fertilisation, excessive proliferation of blue-green algae and may even lead to mass mortality of carps. When this occurs, the only alternative is to discharge the foul pond water into the nearest stream. Such a practice would constitute a source of pollution as well as a health hazard.

The adverse effects of pollution on various lakes and coastal waters in different parts of the world are well-known. Singapore is aware of such problems and strict laws have been legislated against environmental pollution. The more dynamic aspect of the anti-pollution law is the conservation of the reservoirs and the coastal areas which are important potential resources for aquaculture development. Although the use of cess-pits has been introduced to the pig farmers the effluent from these cess-pits can still contribute to environmental pollution, perhaps to a lesser extent. However, if regulated amounts of pig dung effluent were discharged into ponds which serve as a 'buffer zone', not only will it further minimise the effects of organic pollutants but also will provide a good source of organic fertiliser to the ponds for carp production. With these dual objectives in mind preliminary investigations on the utilisation of cess-pit effluent for fish production were carried out.

UTILISATION OF ORGANIC WASTE FOR FISH PRODUCTION

The traditional method of Chinese carp culture incorporates the direct discharge of pig dung into fish ponds. The principle behind this is to enrich the water with pig dung so as to increase fish production. Such a practice

usually causes intense proliferation of undesirable algae and overfertilisation, and may result in mass mortality of fish.

Other methods of organic waste utilisation have been reported. Slack (1972) has successfully cultivated fish in sewage stabilisation ponds. Similarly in India, diluted sewage is released into fish ponds as a fertiliser (Jhingran 1972). Chan (1972) has stated the possibility of culturing fish using sewage effluent after digestion. These methods appear to be an improvement over the traditional Chinese method as the sewage has gone through a certain period of biodegradation before being used.

For the present investigation carried out at the Freshwater Fisheries Laboratory, Singapore, 110 fingerlings of bighead carp (*Aristichthys nobilis* Richardson), silver carp (*Hypophthalmichthys molitrix* Val.) and grass carp (*Ctenopharyngodon idellus* Cuv. & Val.) stocked in the ratio of 5:5:1 respectively in a pond of 550 m², attained a total weight of 78 kg within 6 months. No supplementary feeding was given. This production represents a projected yield of 1.4 tons/ha/6 months.

EFFECTS OF PIG DUNG EFFLUENT ON FISH POND

Chemistry of Effluent and Pond Water

Table I illustrates the results of the chemical analysis of the effluent. In spite of the detention period in the cess pit, it contained substantial amounts of nutrients and a high biological oxygen demand (990 mg/l). With the introduction of 182 litres of effluent into the carp pond at two weeks intervals the nutrient levels of the pond water increased markedly (table II). Total dissolved phosphate values were raised from 0.24 to 0.94 mg/l while a larger amount would be expected to be fixed by the bottom mud as observed by Watts (1965) and Oren

Table I. Chemical analysis of cess-pit effluent

	Mean Value in mg/l	Range in mg/l
Total Solids	1920	150 - 5170
Calcium	77.9	48.0 - 123.6
Potassium	178.0	80.0 - 305.0
Sodium	104.0	20.0 - 400.0
Total Phosphate	251.1	175.0 - 325.0
Sulphate	11.2	2.5 - 17.9
Chloride	74.3	17.5 - 105.0
Ammoniacal Nitrogen	188.7	69.8 - 331.6
Nitrate Nitrogen	8.0	7.5 - 10.0
Biological Oxygen Demand	990	100 - 2200

and Ravid (1969). However pH values were observed to remain around 6.5 even after the addition of the effluent. With the increased influx of dissolved solids from the effluent, alkalinity values increased from 0.31 meq/l to 0.55 meq/l. Dissolved oxygen values in the pond water was also raised and this led to an increase in the primary productivity of the pond from 0.7 mgC/hr/lit to 2.4 mgC/hr/lit after the introduction of the effluent (Table III). In qualitative terms, all these changes point towards a more fertile pond.

Table II. Chemical analysis of pond water before and after introduction of cess-pit effluent.

	Mean Value mg/l Before Introduction	Mean Value mg/l After Introduction
Total Suspended Solids	12.9	26.4
Total Dissolved Solids	49.7	68.9
Calcium	2.7	6.4
Potassium	3.6	10.3
Sodium	4.7	6.9
Total Dissolved Phosphate	0.24	0.94
Total Benthic Phosphate	1.3	4.2
Sulphate	NOT DETECTED	4.8
Chloride	8.7	15.1
Ammoniacal Nitrogen	0.31	0.79
Nitrate Nitrogen	4.7	9.5

Table III. Physico-chemical analysis of pond water before and after introduction of cess-pit effluent.

	Mean Value Before Introduction	Mean Value After Introduction
pH	6.5	6.5
Alkalinity meq/l	0.31	0.55
Dissolved Oxygen		
(Top sample) mg/l	5.9	11.4
(Bottom sample) mg/l	5.6	6.5
Light and Dark Bottle Measurement		
D.O. in Light Bottle mg/l	7.0	13.6
D.O. in Dark Bottle mg/l	5.1	9.8
Primary Productivity mgC/hr/lit	0.7	2.4
Biological Oxygen Demand mg/l	6.5	11.5

Productivity of the Carp Pond

It is apparent that the addition of pig-dung effluent increases the nutrient load in a fish pond. This has been shown to bring about a corresponding increase in the productivity of the pond (Basu, 1965, Beeton and Edmondson, 1972). As the eutrophicity of the pond increases, plankton composition will also change. During the investigations however, the water did not show any trends of becoming soup-like in consistency (Prowse 1964) as we would expect in the traditional carp ponds where blue-green algae proliferate. Examination of the plankton revealed some changes in constitution following the introduction of the effluent. With the introduction of the effluent, green algae decreased from 55.1% to 45.0% whilst euglenoids increased from 34.4% to 51.2%. Although plankton composition remained generally the same with a co-dominance of euglenoids and green algae, BOD values of the pond water showed an upward trend from the initial value of 6.5 mg/l to 11.5 mg/l after the introduction. Although such an increase may cause alarm, what is more striking is the drastic reduction of the BOD of the effluent once it has been discharged into the pond. The effluent with an initial BOD of 990 mg/l

caused a comparatively minimal increase in the pond water. This shows that fish ponds can act as a stop-gap to buffer the deleterious effect of direct discharge of the effluent into the water systems. It must however be remembered that the dilution capacity of the pond is an important consideration at this juncture.

CONCLUSION

As sewage contains substantial amount of nutrients, it constitutes a pollution hazard to the water-systems, reservoirs and coastal waters if directly released. The high biochemical oxygen demand, suspended material, pathogens and parasites (Jhingran, 1972; Chan, 1972) are the sources of pollution associated with raw sewage. However if raw sewage is allowed to undergo a period of biodegradation and self-purification, and be discharged subsequently with proper control, it may be harnessed for aquacultural production. Although the effluent has a high BOD it has been found that the partially digested sewage is suitable for carp culture. Unlike raw sewage the introduction of the effluent into the fish pond has not brought about the usual proliferation of blue-green algae. But what appears more promising in the use of the effluent, is the drastic reduction of BOD values once the effluent is discharged into the pond. The minimal rise in BOD of the pond water after the introduction shows the capacity of the fish pond to absorb the nutrient load. Primary productivity values obtained during the investigations seem to agree with this.

It is apparent that the effluent even after the storage period is still not suitable for direct discharge into streams. The high BOD value and the dissolved nutrients, especially phosphates, can cause eutrophication. To conform with the anti-pollution requirements at discharge, would necessitate the effluent to be further processed, which is very costly. The fish pond has been shown to offer a very profitable alternative. It can be used as a very important 'stop-gap' or 'buffer zone' for the effluent before discharge. Initial investigations reveal that the pond still retains acceptable BOD and productivity levels even after the introduction of the effluent. Hence it appears that the carp pond is not only productive but also serves as biological control for organic pollutants before the effluent is discharged into the streams.

From the results of the preliminary investigation, further studied need to be carried out before a standardized method on the integration of carp production and the biological control of animal sewage pollution of inland and coastal waters can be evolved.

ACKNOWLEDGEMENTS.

The authors wish to express their gratitude to the Director, Primary Production Department for permission to publish the paper; to Mr. Chen Foo Yan for his invaluable assistance in reading and criticising the manuscript and to Mr. Nah Keng Cheng for analysing the cess-pit effluent.

Reference

- Basu, A. K. 1965. Observation on the Probable Effects of Pollution on the Primary Productivity of the Hooghly and Mutlah Estuaries *Hydrobiologia*, 25, 302–316.
- Beeton, A. M. & Edmondson, W. T. 1972. The Eutrophication Problem. *J. Fish. Res. Bd., Can.*, 29, 673–682.
- Chan, George L. 1972. The Use of Pollutants for Aquaculture – Conditioning of Wastes for Aquaculture. 15th Session IPFC Wellington. FAO Bangkok.
- Jhingran, V. G. 1972. A critical appraisal of the water pollution problem in India in relation to Aquaculture. 15th Session IPFC Wellington. FAO Bangkok.
- Oren, O. H. & Ravid, Rosa. 1969. Phosphate in Lake Kinnereth. *Verh. Intern. Verein. Limnol.*, 17, 334–341.
- Prowse, G. A. 1964. Some Limnological Problem in Tropical Fish Ponds. *Verh. Intern. Limnol.*, 15, 480–484.
- Slak, E. B. 1972. Sewage and Aquacultural Production. 15th Session IPFC Wellington. FAO Bangkok.
- Watts J. C. D. 1965. The Chemical Analysis of Muds from the Pond Systems of the Tropical Fish Culture Research Institute. TECRI, Malacca. Investigational Report No. 3

SEAFDEC/SCS.73: S-30

The Seaweed Industry of the Philippines

by

Priscilla Caces-Borja

Bureau of Fisheries
Department of Agriculture and Natural Resources
Republic of the Philippines

INTRODUCTION

Until 1966 the seaweed industry in the Philippines was a negligible item in the country's economy. Seaweeds were mainly used locally. Only a few species were exported. One of these was *Digenea simplex* a uermifuge source, which used to be exported years ago but is now no longer in demand, although there have been occasional inquiries as to their sources. *Galidium* and *Gracillaria* were exported to Japan as sources of agar. With the discovery of *Eucheuma* as a source of Carrageenin for industrial purposes, our natural grounds were exploited and our export of seaweed in 1966 was some 800 tons. In the next five year, our exports dwindled to a mere 318 tons in 1970. This indicated an over-exploitation of our *Eucheuma* weeds so that culture of this weed had to be started. The 1972 statistics now show that exports have gone up to about 570 tons valued at P1.6 million pesos.

The greatest bulk of our seaweed exports go to the United States of America which received 270 tons in 1970. Japan bought 26 tons, France 5 tons, 17 tons went to other countries in this same year.

There are two known exporters of seaweeds in the Philippines: the Marine Collids (Phil.) Inc. at # 7 Masunurin St., Sikatuna Village, Quezon City and the Kah Development Corporation of Cebu City. Marine Collids (Phil.) buys and exports dried *Eucheuma* as raw material.

Some local factories which produce processed *gulaman* bars are the Nomer Chomical Products Inc., in Caloocan City, the Rizal Agar-agar Factory in 47 K Manalo St., San Juan and the Goodwill Products Corporation in 28 Capitan Tiago St., Malabon, Rizal.

What part is *Eucheuma* and what part is *Gracillaria* is not reported but it has been observed that there is a

growing demand for *Gracillaria*. Hence, studies are now being initiated on the culture of *Gracillaria* in addition to *Eucheuma*.

COMMERCIAL USEFUL SEAWEED

There are many species of seaweed found in Philippines waters owing to its warm seas and shallow areas. These are described in the order of their importance.

1. *Eucheuma* (gozo)

Eucheuma, locally known as "gozo" in Visayan, is a red alga which is now the most important commercial seaweed in the Philippines. This alga grows on coral reefs and in the rocky and sandy bottom of marine intertidal or subtidal zones where the water is very salty, clear and fastmoving. The soft body is light brown to light green with erect or prostrate branches. There are various species found in Philippine waters. Of these, *S. striatum* and *E. spinosum* are found best suited for cultivation. At one time (1965–66) it constituted the biggest single marine export commodity of the country. Due to poor conservation practices by gatherers, who take all the available seaweeds of the area and leave nothing to grow, the yearly export of this product has been diminishing for the past five years. For this reason it is necessary to culture this particular genus of seaweeds in order to have a steady supply, as it is badly needed by all developed countries.

Uses: In the Visayas and Mindanao areas, it is common to see *Eucheuma* together with other species of seaweeds offered for sale in the market. They are eaten raw as salad. *Eucheuma* is commercially important due to its demand for industrial uses. From this alga is taken or extracted "carrageenin", a valuable substance used in products that need gelling, suspending, thickening or water-holding

properties. There are countless products needing carrageenin such as ice cream, peanut-butter, paints, cosmetics, textiles, rubber products, etc.

Sources: There are various places where *Eucheuma* may be found growing in a natural state. The biggest natural ground and best areas for farming are the wide shallow areas in the Sulu Archipelago, where these grow in great abundance. Other good growing areas are around Zamboanga, Palawan, Cebu, Bohol Samar, Surigao and Polilo. They may also be found in Pangasinan, Mindoro, Negros Panay, Leyte, Masbate, Catanduanes, Batangas, Camarines Norte, Camarines Sur, Davao, etc. and practically around all small island of the country, although the distribution is affected by the seasons.

2. *Gracilaria* (gulaman dagat)

Gracilaria confervoides (gulaman dagat) is the species most extensively used in agar manufacture in the Manila area.

Gracilaria is our main source of agar-agar or *gulaman*. The value of agar lies in its strongly hydrophilic colloid and high gelstrength qualities. It is used where bulk is wanted, or where a suspending, stabilizing, thickening or gelling agent is desired. It is used in some bakery and dairy products and in candy, jelly, canned foods and other items. Its most important service to mankind, however, is as a bacteriological culture medium, although the amount used for this purpose is relatively small. In the fresh state, this is used for food in the form of salad and also as supplemental food for the baños *chanos chanos*. Quite recently, *Gracilaria* became a big export item in our economy. Japan especially was our biggest importer of the product, so that a need for development of the industry, especially keeping up a constant supply through its culture, is in order.

Sources: The greatest amount of this seaweed comes from Manila Bay area, from November to May. Other sources are Zamboanga, Sulu and Cagayan. This seaweed is gathered by the use of rakes in areas from the shore to a water depth of one to two meters. When the Southeast wind (habagat) blows all the *Gracilaria* are uprooted and washed to the shore by the strong waves. These, however, have left spores in their growing areas and these grow again during the following season so that there is a natural closed season for the seaweed, and there is provision for a supply every season. However, with indiscriminate gathering these weeds may not get a chance to reproduce and therefore the fishery may be depleted.

3. *Gelidium* – agar weed

The entire plant reminds one of the frond of a fern and is sometimes known as “sea-fern.” It grows in tufts and attaches itself firmly to the rocky substratum by numerous rhizoidal filaments. *Gelidium* grows most abundantly around the edges and on the slanting surfaces of rocks and boulders in places where the water is generally turbulent and the water movement fast. They abound in the intertidal and subtidal littoral zones.

This is one of the sources of high quality agar and is very much in demand in Japan.

4. *Porphyra* (gamet)

Gamet is another seaweed of great commercial pos-

sibility as food and livestock feed. It is similar to the *amanori* (*Porphyra tenera*) of the Japan. Tseng (1944) reported that Japan was able to convert 12,000 acres of her useless rocky shores into a sea garden of *amanori*, giving that country an annual income of no less than \$3,000,000. This seaweed is found in abundance along the shores of Burgos, Claveria, Aparri, and other towns of the northern provinces of Luzon growing on boulders that are sprayed by sea water. It is a delicacy among the Ilocanos and is the most common edible seaweed.

Gamet may be cultivated by collecting their spores and allowing them to grow during the months of November to March.

The fronds of seaweeds are plucked and washed thoroughly in fresh water and dried under the sun. The dried *gamet* appears like thin sheets of paper, shiny and dark green. These can be eaten with soy sauce to improve the taste.

5. *Codium* (pokpoklo)

Another species of seaweed that is consumed as food in the fresh state is *Codium* (pokpoklo).

Codium is low in food value but is exceptionally high in potassium. It is highly watery in the fresh state (93% moisture) and is much relished as food by the Ilocanos. This can be found in Ilocos Norte and Gagayan.

6. *Caulerpa* (lato or ararosep)

Caulerpa is also low in food value but widely used as food in northern Luzon, Visayas, Mindanao and Sulu. Recent studies of our peppery type of *Caulerpa* at the University of Hawaii show the possibility of deriving some active alkaloids for certain medicinal purposes from this source.

7. *Sargassum*

Sargassum, a brown alga, that has been reported floating in great abundance in the marine waters all over the Philippines grow attached to some anchors at the bottom, but are eventually destroyed by wave action and currents. These are most abundant in the coral reef areas like the Hundred Islands in Pangasinan, the Palawan area, Mindoro, Cebu, and Batangas. It was found to have a high content of alginic acid and may be used in the production of commercial alginate chemicals. Because of the high amount of minerals present in the ash in the form of calcium and potassium, the waste materials may be useful as fertilizer. There are great possibilities for this alga.

8. *Digenea simplex* (bodo-bodo)

Another kind of seaweed, *Digenea simplex*, found in the northern coast of Luzon, has an immediate value as medicine. It is locally known as *digenea* and *tserkoots'ai* or *Hayen-ts'ao* in Chinese. Pharmaceutical preparations such as macnin and helminal, are derived from this seaweed. It is an efficient vermifuge and is claimed to be much better than santonin as it gives no secondary bad effect, especially to children. It contains an appreciable amount of agar although of poor gelling quality.

It is also reported to be eaten fresh or dried by some people.

9. *Hypnea*

This red seaweed is good material for the extraction of

commercial agar. It is also being utilized directly as food in many parts of the Philippines like Manila Bay, Mindoro, Zamboanga and Santa Ana, Cagayan.

10. *Turbinaria*

This brown alga, like *Sargassum* could be tapped commercially as good material of alginic acid. It has been reported in Cebu and Sulu.

11. *Hydroclathrus*

This is another source for alginic acid. Its main source is Pangasinan.

USES OF SEAWEEDS

Seaweeds are major sources of agar, alginic acid and carrageenin. The red algae are generally sources of agar and carrageenin. While the brown algae are sources of alginic acid.

The uses of agar are manifold but probably its most important use is in bacteriological and fungal culture work.

Some of the many products in which seaweed extracts are used as follows:

Pharmaceutical products

- Aureomycin tablets
- Terramycin suspensions
- Triple sulfa tablets
- Penicillin suspensions
- Anti-acid tablets
- Sulfa suspensions
- Aspirin compound tablets
- Calamine lotion
- Hemostatic powders
- Baking laxatives
- Dental impression compounds
- Toothpaste
- Orthopedic impression compounds
- Surgical jellies
- Suppositories
- Mineral oil emulsions
- Rubbing ointment

Miscellaneous food products

- Bakery icings and meringues
- Salad dressings
- Frozen foods
- Fountain syrups
- Orange concentrates
- Candy
- Puddings

Rubber

- Natural and synthetic latex creaming and thickening
- Finished articles
 - Automobile carpeting
 - Electrical insulation
 - Babies, rubber pants
 - Foam cushions
 - Rubber coating
 - Tyres

Textile products

- Size compound for cotton and rayon
- Textile print pastes
- Plastic laundry starch

Dairy products

- Ice cream
- Dry ice cream mix
- Sherbet
- Chocolate milk
- Chocolate toddy
- Sterilized cream
- Cheese

Adhesive

- Wall board
- Paper bags
- Shipping containers
- Gummed tape
- Decals

Paper products

- Food packages
- Pharmaceutical soap and detergent packages
- Milk containers
- Butter cartons
- Frozen food packages
- Insulation board
- Food wrappers
- Greaseproof paper
- Acoustical tile

Miscellaneous products.

- Paints
- Ceramic glazes
- Porcelain ware
- Leather finishes
- Auto polishes
- Welding rod coatings
- Boiler compounds
- Battery plate separators
- Wallboard joint cement
- Beet sugar processing
- Wax emulsions

Economic and Social Aspects of the Resources

by

S. Iwakiri
Faculty of Fisheries, Kagoshima University
Kagoshima, Japan

Oral presentation was made by the author along the following lines.

1. Definition of the subject
 - 1-1 Theoretical limitation of fisheries resources from viewpoint of fishery economics.
 - 1-2 Relations between industrial resources and biological resources.
2. Target of resources exploitation in the aspects of economic development policy.
 - 2-1 Obtaining of foreign currency by fisheries development.
 - 2-2 Increase of domestic supply of animal protein food which will result in improvement of fishermen's standard of living
3. Different types of fisheries management and economic scale in the fisheries development by reason of resources classification
 - 3-1 Scales of production unit according to the fertility, location and market of the resources.
 - 3-2 Household fisheries – Inshore or scattered fishing. Enterprise fisheries – Offshore or mass product fishing.
4. Problems on the economic development of the fishing community.
 - 4-1 Maintenance of a certain balance between inshore fisheries and limited resources.
 - 4-2 Condition and restriction on technical improvement of traditional or small fishing gears.
 - 4-3 Break through from conventional control in fishing communities to fisheries on cooperative society.
5. Problems on the introduction of enterprise scale fishing.
 - 5-1 Adoption of financial assistance program, business analysis and management system.
 - 5-2 Development of infrastructures and replenishment facilities.
 - 5-3 International price competition and price fluctuation in fisheries products.
6. Socio-economic role of the national fishery regulation to avoid a conflict on fishing among different sub-sectors of a fishing industry
 - 6-1 Prevention of excessive competition in fishing management.
 - 6-2 Realization of optimum sustainable yield and international allocation on the living resources.
7. Fish marketing and price formation
 - 7-1 Mobilization of merchant capital into the promotion of fish processing industry.
 - 7-2 Concentration of fish landing place as a measure for price stability.

Partial Bibliography on Biology and Culture
of Penaeidean Shrimps and prawns in Asia

by

Katsuzo Kuronuma
Tokyo, Japan

The original paper submitted to the seminar was with drawn by the author, because the following paper, newly published by FAO, covers the contents of his paper.

Preliminary bibliography of fish and fisheries with special reference to shrimps and prawns, IPFC, Occ. Rap. '75/3, pp. 136, compiled by Agnes Jiannee, Technical Assistant, Fisheries, FAO, Regional Office, Bangkok.

Major fisheries in Thailand and some technical
recommendations for their improvement

by

Yasumasa Nishioka and Tomeyoshi Yamazaki
Training Department
Southeast Asian Fisheries Development Center
Bangkok, Thailand

CONTENTS

1. Statistics of principal fisheries in Thailand
2. Present major fisheries in Thailand
 - 2.1 Trawl fishery
 - 2.2 Indo-Pacific mackerel purse seine fishery
 - 2.3 Bonito purse seine fishery
 - 2.4 Indo-Pacific mackerel encircling gill net
3. Recommendation for future fisheries in SEAFDEC area
 - 3.1 Skipjack pole and line fishery
 - 3.2 Mechanized squid line fishery
 - 3.3 Vertical long line fishery
 - 3.4 Mid-water trawl fishery
 - 3.5 Philippines lift net fishery
 - 3.6 Jellyfish fishery

1. STATISTICS OF PRINCIPAL FISHERIES
IN THAILAND.

The FAO yearbook of fisheries statistics for 1970, states that the catch of fish in Thailand ranked eighth in the world, and fish production in the same year was 1,595,100 tons, an eightfold increase compared with the catch recorded for 1958, 196,300 tons.

(a) Catch in quantity

Fish species or group of species whose production exceeded 5,000 metric tons.

Name of fish	Metric ton	% to the total
1 Trash fish	438,999	35.2
2 Indo-Pacific mackerel	100,505	8.1
3 Miscellaneous fish	88,109	7.1
4 Sardine	28,803	2.3
5 Anchovy	15,513	1.2
6 Indian mackerel	14,916	1.2
7 Threadfin bream	14,896	1.2
8 Jew fish	13,254	1.1
9 Marine catfish	11,872	1.0
10 Lizard fish	11,066	0.9
11 Big eye snapper	10,627	0.9
12 Spanish mackerel	9,201	0.7
13 Ray	6,869	0.5
14 Bonito	5,631	0.5
15 Shark	5,631	0.5
(Crustaceans)		
Shrimp	68,743	5.5
Crab	18,876	1.5

(Molluscs)		
Squid	23,528	3.0
Cuttlefish	13,253	3.0
Shellfish	292,728	24.5

(b) Catch in value

Ten major commercially important species.

Name of species	1,000 Baht	% to the total	Unit price per Kg (Baht)
1. Exportable shrimps	726,617	23.3	30.00
2. Indo-Pacific mackerel	452,273	14.5	4.50
3. Miscellaneous fish	440,505	14.1	5.00
4. Trash fish	263,399	8.5	0.60
5. Squid and cuttlefish	194,224	6.2	—
6. Other shrimps (for drying)	119,766	3.8	—
7. Sea mussel	85,837	2.8	—
8. Crabs	76,087	2.5	—
9. Spanish mackerel	73,608	2.4	8.00
10. Jew fish	46,389	1.5	3.50

(c) Catch by type of fishing method (1971)

Type of fishing method	catch (Ton)	% to the total
Otter trawl	515,599	41.50
Pair trawl	138,334	11.10
Beam trawl	4,989	0.40
One boat and two boat		
Purse seine	66,520	5.33
Anchovy seine	8,585	0.69
Spanish mackerel gill net	11,578	0.93
Pomfret gill net	938	0.08
Mackerel encircling gill net	53,722	4.31
Shrimp gill net	10,195	0.82
Other gill net	38,118	3.06
Luring lift net	4,454	0.36
Squid cast net	363	0.03
Push net	14,200	1.14
Scoop net	143	0.01
Other net	30,576	2.46
Bamboo stake trap	19,672	1.58
Set bag net	14,914	1.20
Wing set bag net	313	0.03
Ebb tide bamboo stake trap	356	0.03
Shrimp bamboo fence trap	5,152	0.41

Fish trap	733	0.06
Crab trap	2,922	0.24
Other stationary gear	1,624	0.13
Collecting shellfish*	299,832	24.02
Jellyfish fishing	35	0.00
Shrimp culture	954	0.08

2. PRESENT MAJOR FISHERIES IN THAILAND

2.1 Trawl fishery

2.1.1 historical background

The first trial of trawling in Thailand seems to have been made in 1952 by the American owned Gulf Industry Co. Ltd. with the cooperation of an Australian fisheries expert. They operated six trips using two otter trawlers, INSRIGHUM Nos. 1 and 2 (47 ton, 250 horse power), however gave up the operation with unsuccessful results. During 1953 to 1954, Thai Trading Co. Ltd. made shrimp beam trawling and otter trawling with YANAMARGO (5 T., 16 HP.), to which a Japanese expert joined, and their results were successful to some extent. Pair trawl operations were made for two months in 1953 by MUICHIN No.s 1 and 2 (50 T., 100 HP.), Kit Paisal Co. Ltd. Between 1955 and 1961, Thai Trading Co. Ltd. made somewhat large-scale trawl operations using SAMURUAT SATNAM No.s 1 and 2 (20 T., 120 HP.). During January to June 1955, they made otter trawlings in the Gulf of Thailand and surveyed some fishing grounds. From September 1955 to March 1961, the trawlers made operations converting into pair trawling. In 1959, there operated totalling over 300 beam trawlers and over 16 pair trawlers.

In 1960, some German trawl experts were sent into the country, and in the succeeding year the Department of Fisheries demonstrated otter board trawling to the local fishermen. Since that time, otter trawlers increased rapidly in number and a brilliant epoch was introduced in the fisheries in Thailand. Total number of trawlers exceeded 3,000 in 1973. This comprises more than 70 large-size trawlers (100–200 T., 400–1,000 HP.) operating in high sea and the large size trawlers are still increasing in number.

2.1.2 Present situation

The present total number of trawl fishing unit throughout the country is estimated to be 3,608, roughly divided into 2,472 otter trawlers, 522 pair trawlers and 614 beam trawlers. Of the otter trawlers those below 14 m in length share 35 per cent, those between 14 and 8 m are 40 percent and 18 m and above are 25 percent respectively. Pair trawlers classified into the above three categories are 5, 10 and 85 percent respectively. Beam trawlers less than 12 m and 12 m over are 80 and 20 percent respectively.

Most of the trawlers are equipped with diesel engine,

*) Including culture products.

and the over 70 large sized trawlers mentioned above are of 400 to 1,000 horse power. Almost all otter trawlers and pair trawlers are equipped with winches, with the exception of beam trawlers: Small, medium-size and large trawlers use manual, drum type and mechanical winches. The drum type and mechanical trawl winches are of 150 to 250 and 250 to 1,000 horse power respectively.

In Thailand, roughly speaking, three different types of trawl net are in use; German type two seamed (Fig. 1), Mexican type four seamed (Fig. 2), and four seamed trawl net. Two seamed net, introduced in 1960 by German

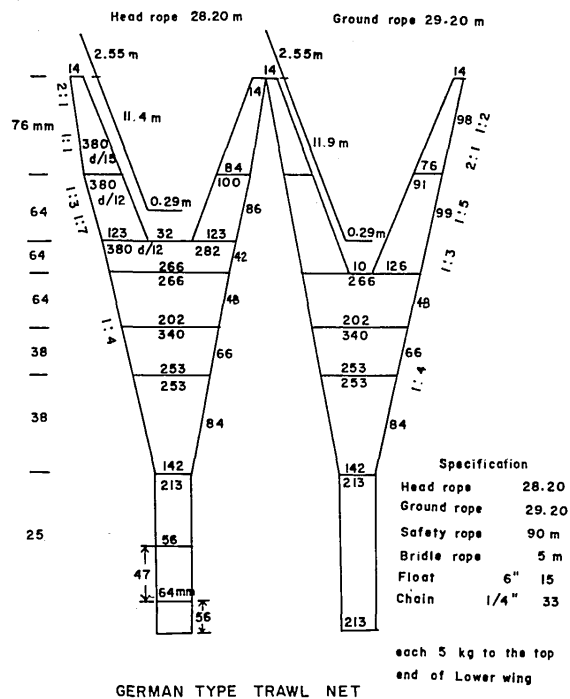

Fig. 1 Design diagram of German type two-seam trawl net.

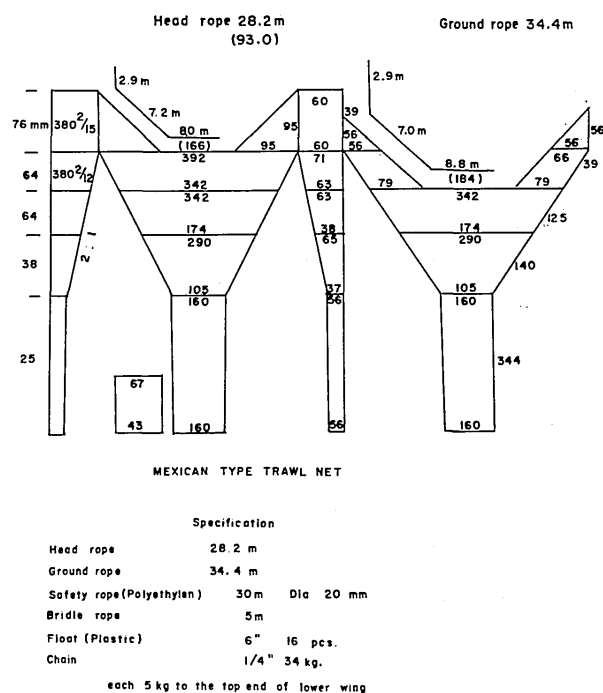

Fig. 2 Design diagram of Mexican type two-seam trawl net.

fisheries experts, are mainly used for catching shrimp. In 1972, comparative studies on catch efficiency were made by the Training Department, SEAFDEC with the cooperation of the Department of Fisheries in Thailand, on the above different types of two-seamed net and four-seamed net, and the Mexican type was found to be superior in catching shrimps. The four-seamed net, popular in Japan, Korea and Taiwan, is used for catching demersal fish. This type of net has a higher opening in action, therefore the net is expected to catch more fish. In Thailand the four seamed nets are mainly used by large trawlers. This type of net was introduced in 1953 by Japanese experts and after modification trials Thai fishermen made up the present type. The mesh of the cod-end part of the trawl nets ranges from 1.5 to 1.6 cm. However, the mesh of the inner netting is between 1 and 2 cm. Trawling duration is usually 3.4 hours on an average, though towing near the border between Thailand and Cambodia sometimes lasts 6 hours. Towing duration of Japanese trawlers is in the range of 0.5 to 2 hours in contrast to that of Thai vessels.

Beam trawlers operate mainly in shallow waters near estuaries. Otter trawlers with shrimp as their main object usually operate from evening to morning, one night each trip. Otter trawlers and pair trawlers, aiming mainly for squid, operate a full day from morning to evening. Larger otter trawlers and pair trawlers, ranging 80 to 150 tons and 250 to 450 horse power, pursue mainly valuable and large-size fish. Their fishing grounds are mostly in the open sea, off the west coast of Vietnam, off-shore waters near the border of Thailand and Malaysia, off the coast of Sarawak, near the river mouth of Irawaddy, and in the Bay of Bengal. They usually make ten to fifteen day trips. Large trawlers which are based in Singapore operate off Sarawak, near the mouth of the Irawaddy, and in the Bay of Bengal and land their catch in Singapore.

Demersal fish resources in the Gulf of Thailand have greatly decreased in recent years. The fishing grounds there are fully exploited and consequently the size of the catch is becoming smaller. On the other hand, however, squid is greatly increasing with the decrease of big fish. The fishing grounds for squid are mostly on the sandy bottom, and the depth ranges from 5 to 30 m. Full exploitation has also reached to the squid resources and as a consequence the catch per boat is increasing and size of catch is becoming smaller. For large trawlers, therefore, good catch cannot be expected in the territorial waters of Thailand but only in high sea fishing grounds.

At present, the large-size trawlers range between 100 and 200 tons, with more than 400 up to 1,000 horse power, and trawlers are still becoming larger in size; some enterprises are planning to build 400–700 ton trawlers. Since the commencement of trawling by Thai vessels in the Bay of Bengal in 1972, Thai trawlers operating there are rapidly increasing in number. Prosperous fishing grounds in the future might be in the Bay of Bengal, the Gulf of Tonkin and off the north coast of Australia.

2.1.3 Recommendations for the future

The otter board trawlers in use at present have mostly been converted from fish carrier, it would be better to

change these into stern trawlers. Since the market price of frozen fish is cheaper than that of chilled fish, it is not necessary to install freezing equipment at present. However, refrigerating systems should be urgently improved to keep ice from melting and to provide chilled sea water. This would help to keep the catch fresh. Four or six-seam trawl nets are recommended for catching large-size fish, these are expected to be more effective than the two seam nets now in common use. On the other hand, mesh size regulations should be made considering the increase of fishing intensity. Most of the larger trawlers operate for twenty four hours; i.e. the towing duration of each haul is 4 hours, therefore it takes 24 hours for six operations. Since, in tropical waters as in the SEAFDEC area, long towing time decreases the freshness of the catch, each towing duration is recommended to be two hours at longest. The shrimp trawlers, towing six hours each haul at present, should reduce their towing time to within one hour. For trawlers below 200 tons, pair trawlers are distinctly more effective than otter trawlers. Considering the present situation of demersal fish resources in the territorial waters some regulations for fishing operation seems to be necessary. In conjunction with the above, fisheries surveys are recommended in the Gulf of Tonkin and the waters off the north coast of Australia as potential fishing grounds where large vessels might operate in the future.

2.1.4 Recommendations for SEAFDEC member countries

The member countries should take precautions not to exhaust their demersal fish resources. The trawlers used at present should be changed to stern trawlers. The Mexican type two seam trawl net is more effective for shrimp otter trawling; for both the otter board and pair trawlers which seek large fish four or six seamed nets are more efficient.

Shrimp trawlers in Thailand are small in size and operate independently without cooperation of other vessels. However, in order to determine the migrating routes of shrimp and catch them effectively, multiple-ship operation is recommended. In American shrimp trawl fisheries, a fleet of more than ten boats usually operates cooperatively exchanging information about fishing grounds and fishing conditions by telecommunication. Therefore, adaptation of multiple-ship shrimp trawling is also recommended in the SEAFDEC area. It seems urgently necessary for fishermen to follow the proper manner of fish processing on board, because the market price of a catch depends mainly upon its freshness.

2.2 Indo-Pacific mackerel purse seine fishery

2.2.1 Historical background

This fishery originated from the traditional *Owan-Dam*, which was a Thai surrounding net operated by man-power using a single row boat. In an early stage of developing one-boat purse seiner, from traditional ones into those of the present day, they were not widely accepted as the two-boat seiners, because of their inferior machinery system.

The present one-boat purse seiners owe much to Japanese fishing gear experts. In 1956, they demonstrated

one boat purse seining with successful results. At the same time, it was recognized that this type of gear did not entangle with the screw propeller during operation. Another merit is that a one-boat purse seiner is increasing in number and it is taking the place of the two-boat type.

The two-boat purse seine came originally from Fukken, China and is hence called Chinese purse seine or *Owan-Tankei*.

This type of purse seiner consists of a engine powered mother boat (15t–30 taons) and two smaller non-powered boats. When locating fish schools, the master fisherman keeps a lookout for them from the top of the mast on board the mother ship. When a fish school is found, the two small boats start to encircle it paying out the seine to surround the fish school within the purse seine. Finally the fish are caught by pursing the seine net. However, with this type of purse seine the gear size is limited by the boat size, and therefore a large catch is not expected in each operation. For the reason mentioned above, the two-boat purse seiners are at present decreasing in numbers.

In 1960, some Japanese type two-boat purse seiners, much bigger than the ordinary Thai seiners, operated in the Gulf of Thailand. However, their results were not successful because the fish schools there were mostly small in size.

2.2.2 Present situation

Most of the purse seiners in Thailand are powered by engine, and operate their gears on the foredeck. For pursing the lines and other uses, drum type winches installed are powered by modified automobile engines. Their chief particulars are as follows:-

	one-boat purse seiners	Two-boat purse seiners
Tonnage	10– 40	20– 40
Horse power	30–150	60–150
Speed (Kt.)	7– 9	7– 9

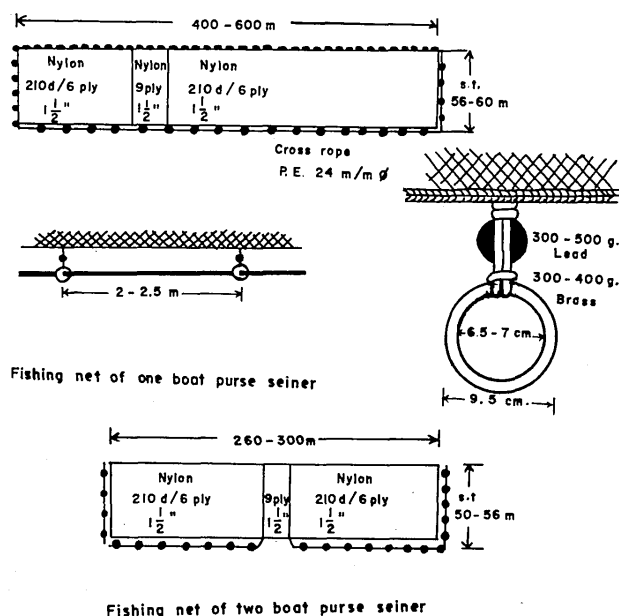

Fig. 3 One-boat and two-boat purse seine nets.

Purse seines now in use are made of synthetic fibers such as nylon or mix-twist of nylon and saran, and are treated by heat setting with resin for the purpose of stiffening the twine. The fishing gears of one-boat and two-boat purse seiners are shown in Fig. 3. Thai fishermen use Polyethylene crossing laid rope as a purse line instead of wire rope, because this crossing laid rope never causes any kinking and is easy to handle during operation. Sinkers are not directly attached to the sinker line but to the ring ropes. This method of construction seems to be effective to prevent entangling the sinkers with the bottom margin of the net. However, a disadvantage is that the sinking speed is much slower as compared with the Japanese or European type.

To detect fish schools, the following methods are adopted by Thai fishermen.

- 1) A watchman observes visually to spot fish schools from the mast during evening and early morning.
- 2) Even during dark nights, fish schools are detected by looking for plankton luminous effects caused by swimming fish.
- 3) Some fishermen are acoustically very sensitive, and can detect fish schools by diving or submerging their ears in the water to listen for the sound of swimming fish.

The technique originally came from Malaysia. Although these methods may appear rather primitive, they are as effective as using a fish finder. Sometimes, the fishermen can recognize the species of fish or shrimp and can predict the direction of movement and a rough estimation of the amount. In the Gulf of Thailand fish schools are rather small in size and occur over a wide area. Consequently, the above methods are popular and widely adopted in place of using fish finders.

The following methods are in use for fish luring:-

- 1) Utilizing the natural inclination of fish to gather in a shady place, coconut leaves are suspended at various depths in water to attract fish.
- 2) At night, three or four lamps are suspended just above the water on one side of the fishing boat to attract fish.
- 3) Though dynamite fishing is illegal, sometimes this method is utilized. Floating fish killed by dynamiting are gathered by the use of the purse seine. It is regretted that some fishermen are still using dynamite.

There are two ways of shooting nets for one-boat purse

- 1) Shooting from the bow, developed from the Thai purse seiner, *Owan-Dam*.
- 2) Shooting from the side, developed from encircling gill netting.

The fishing operations are usually carried out in areas not affected by the monsoon. Therefore the fishing grounds are changed according to the season. Because of this purse seine fishermen know well the migratory routes of fish schools. Fishing operations take place throughout the year except during the spawning season, because fishing in the spawning season is regulated by law. Fishing grounds are usually within 3 nautical miles from shore and at depths below 40 m. Major fishing bases for purse seiners are shown in Fig. 4.

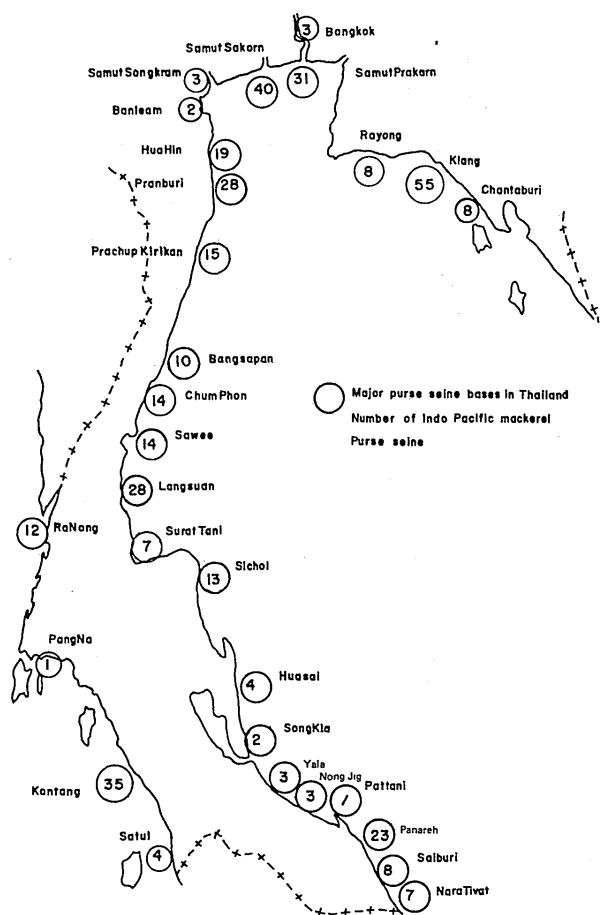

Fig. 4

2.2.3 Recommendations for the future

During operations Thai fishermen haul up the purse seine into the fore deck. As this method is inconvenient and laborious for the crew, it would seem to be better to utilize the stern deck in place of the fore deck. At present many fishermen are needed to carry out the laborious work, such as hauling up the purse seine. However, if a net hauler were installed, it would greatly reduce the laborious work involved and consequently the number of crew could be greatly reduced. Comparatively light weight sinkers are attached to the present purse seine and this has only a moderate effect on the sinking speed of the net. To facilitate the sinking of the net heavier sinkers should be used. With the use of heavier sinkers, the number of escaping fish would be lessened.

As mentioned before, the purse seine fishermen detect fish schools by finding luminous plankton during night time. However, this method is applicable only in calm seas and on dark nights. Therefore, they do not go fishing around full moon nights or under rough sea condition, and this reduces greatly the number of fishing days. It would be beneficial if Thai fishermen had other methods which could be used in place of the present method, as is done in Endau Pahang state, Malaysia. The following are the fish detecting methods used in Malaysia:-

Time	Method	Species of fish
1) Before dawn	By finding luminous plankton	Indo-Pacific mackerel, sardine, small bonito.
2) Early morning	By visual observation near the surface	Sardine, Indo-Pacific mackerel, small bonito
3) Morning	By hearing sound	White shrimp, sardine, thread-fin, goat fish
4) Afternoon	By attracting fish around coconut leaves submerged in water	Sardine, horse mackerel
5) Evening	By visual observation near the surface	Sardine, Indo-Pacific mackerel, small bonito
6) Dark night	By finding luminous plankton, by attracting fish with lamps	Sardine, Indo-Pacific mackerel, squid

Squid are caught by the use of purse seine, after attracting them towards the fish lamps. This method is recommended for study and practice by fishermen in this region in the near future.

2.2.4 Recommendations for SEAFDEC member countries.

The size of fish schools in the Southeast Asian waters is small compared with those in mid-latitude waters. Therefore, the purse seines used in these areas are usually smaller in size than those in U.S.A. or Japan. However, the time necessary to complete one operation with this type of gear is much shorter and consequently more operations are possible in a day.

For purse seine fisheries in the Southeast Asian region, the above mentioned methods which have been adopted along the coast of Malaysia should be improved to install machinery such as a winch and net hauler.

Good refrigeration facilities are not yet installed in most of the purse seiners in the Southeast Asian area. For preservation of fish captured at present, crushed ice is loaded in the fishing boats. However, the fish cannot be kept fresh for a long period by this method. Therefore, the method combining ice and sea water is recommended for the preservation of fish on board.

Nylon twine is widely used at present for making the purse seine instead of cotton or saran as used previously. The material used for purse seine nets should be stiff and should not absorb water. More over it is hoped that the fish caught are not gilled or stuck into the net. For the purpose of minimizing the chance of fish being gilled or stuck into the net, nylon 6 or 7 filament should be used in place of nylon 15 filament or 24 filament.

2.3 Bonito purse seine fishery

2.3.1 Historical background

This fishing method for bonito was developed about eight years ago by Mr. Nakorn, an owner of purse seine boats in Paknam-Pranburi. In those days webbing of saran and nylon mixed twist 210 d/6 ply, 1½" in mesh size was commonly used for all purse seines, and most of the purse seine was less than 450 m in float line length. However, the purse seine constructed by him was 600 m in length and of nylon 210 d/9 ply with the same mesh size. This purse seine was very successful for bonito fishery.

2.3.2 Present situation

At present over 100 bonito seiners are operating in the Gulf of Thailand, and about 60 of them are based in Paknam-Pranburi. Fishing boats used for this fishery are made of wood, and are one-boat purse seiner of foredeck operation type. Main specifications of the boats are as follows:-

Size (Gross tonnage)	35 – 50
Engine (Horse power)	150 – 200
Winch	Drum type

Specifications of the fishing gear used are shown in Fig. 5, and a unit is illustrated in the upper part of the figure.

Name of parts	Twine size	Mesh size	Depth	Length
Selvedge	210d/18ply	1¾ (4.0 cm)	6 meshes	40 m (constructed) 44 m (constructed)
Webbing	210d/9ply (210d/12ply for cod end part)	1½" (3.8 cm)	800 meshes	1,400 meshes

The stretched length of unit webbing 53.3 m (3.8 cm x 1,400 meshes) is hung in to be 40 m and 44 m in constructed length for float line and sinker line, respectively. Weight of unit net in air is 24.8 kg and in water 2.87 kg. These units are laced together to construct the whole net (Fig. 5).

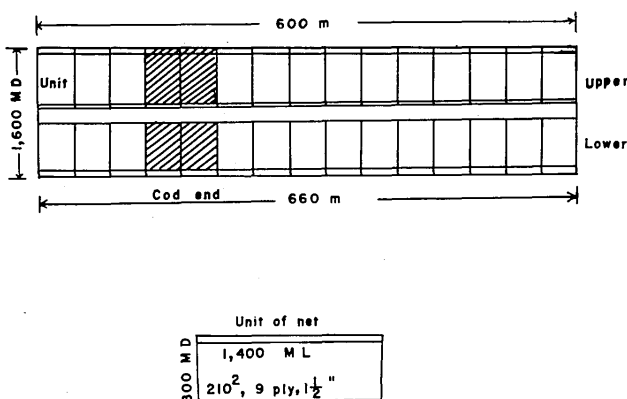

Fig. 5 Bonito purse seine net.

Name of parts	Hang-in	Constructed depth	Constructed length
Upper part	0.25	20 m	600 m
Lower part	0.18	27 m	660 m

Details of ropes used are shown below:-

Name of part	Diameter	Length	Remarks
Float line	6 mm	600 m	S – and Z – twist of ropes are used together
Sinker line	6 mm	660 m	– do –
Purse line	24 mm	600 m	Cross laid rope*

* Breaking strength of the cross laid rope is 4 and 7 tons for Polyethylen and Nylon, respectively.

2,000 pieces of synthetic floats (Naigai No. 8) are attached to the float line (Fig. 6). Weight in air, specific gravity, and buoyancy of each one are 70 g, 0.25, 210 g, respectively. Therefore total buoyancy corresponds to 420 kg. A total of 220 pieces of lead sinker, each 500 g. in weight, are attached to the sinker line 660 m in length at regular intervals of 3 m (Fig. 7). The weight of each piece of lead in water is 455 g and therefore the total weight of the sinker in water is 200 kg. The same number of purse rings as the lead sinker are set at the same intervals. The ring is made of bronze (specific gravity is 7.8) and weight in air and size are 500 g. and 10 cm in diameter. The weight of each ring in water is 435 g. and consequently the total weight in water is 95.7 kg. The weight of net in water is 86 kg. Therefore, the extra buoyancy is equal to 138.3 kg. (= 420 – 100 – 95.7 – 86). The fishing boat used is 199 m in length and 40 tons weight with a 60 horse power engine.

Details of each fishing operation are as follows:- 5 min. are necessary for casting net, 75 min. for hauling (hauling from each boat side takes 37 min.). Therefore hauling speed is 17 m per min. (= 600 m/35 min.). The purse seiners in Japan and U.S.A. usually operate in the daytime when skipjack and bonito are active. Contrary to this, Thai bonito purse seiners usually operate at night when skipjack and bonito are not so active, therefore, they can catch them even with a small and low speed boat.

The fishing seasons and changes of fishing grounds are affected by monsoons, and tabulated below.

Month	Activity	Fishing ground
January	None	–
February	Moderate	Around Rayong
March	"	"
April	"	"
May	None	–
June	"	–
July	Moderate	Around Pranburi
August	Intensive	"
September	"	"
October	Moderate	"
November	None	–
December	"	–

One complete set of purse seine costs 90,000 Baht. The details are: 6,600 Baht for netting, 2,200 Baht for purse rings, 6,500 Baht for floats, 770 Baht for lead sinkers, and 15,000 Baht for other expenses. On an average, catch landings are estimated to be 10,000 to 35,000 kg per month. Of total landings, 30 percent are bonito and the other 70 percent are Indo-Pacific mackerel, their prices are 2 to 4 Baht per kg respectively. Taking the average price of fish landed to be 3 Baht per kg, the above landings are assessed to be 30,000 to 1,000,000 Baht per month.



FLOAT

Fig. 6 Arrangement of floats for bonito purse seine.

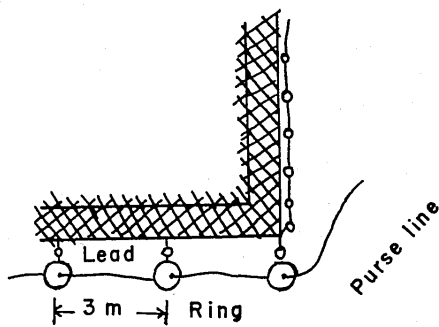

LEAD AND RING

Fig. 7 Arrangement of sinkers and purse rings for bonito purse seine.

Twenty to twenty-two days a month can be used for actual fishing and the number of fishing operations ranges from 3 to 4 times a day. Therefore, the average catch per operation is estimated to be 136 to 470 kg., dividing the catch amount per month (10,000 to 35,000 kg.) by the average number of fishing operations per month (21 x 3.5).

Of the income, 50 to 60 percent goes to the owner and 40 to 50 percent to the crew, though the expenditure for fuel, food and repairs is paid by the owner. Usually 18 to 21 persons are on board and their allocation ratio is shown below.

Staff	Number	Allocation ratio
Captain	1	2
Assistant Captain	1	1.5
Master Fisherman	1	5
Engineer	1	1.5
Quartermaster and Netmakers	3	1.5
Fishermen	11-14	1

2.4 Indo-Pacific mackerel encircling gill net fishery

2.4.1 Historical background

This type of net may be roughly divided into two groups:- 1) Encircling gill net without purse line. 2) Encircling gill net with purse line. The encircling gill net without purse line has a long history from before the 2nd World War, and is used in shallow waters, while the latter fishing gear developed around 1965 in Thailand and its use has increased rapidly. At present the number of Indo-Pacific mackerel encircling gill nets with purse line is roughly estimated to be some 2,000 units in the Gulf of Thailand. However, some of the gill netters are converting to one-boat purse seiners.

2.4.2 Present situation

The fishing boats used for encircling gill net without purse line are of foredeck operation type, they are in the range of 10 to 20 tons and of 30 to 90 horse power and most are equipped with a drum type winch. The fishing gears used are shown in Fig. 8.

The encircling gill net without purse line is mostly

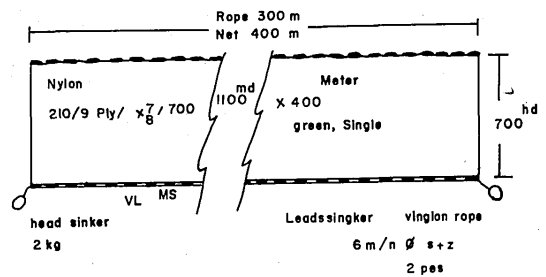

Encircling gill net without purse

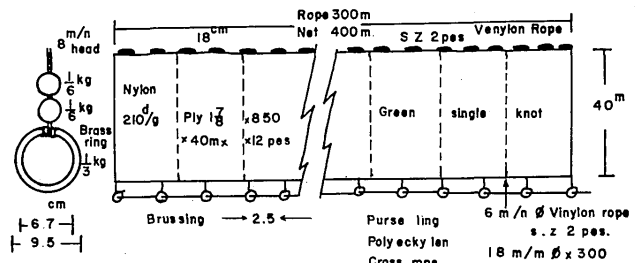

Encircling gill net with purse line.

Fig. 8 Encircling gill nets.

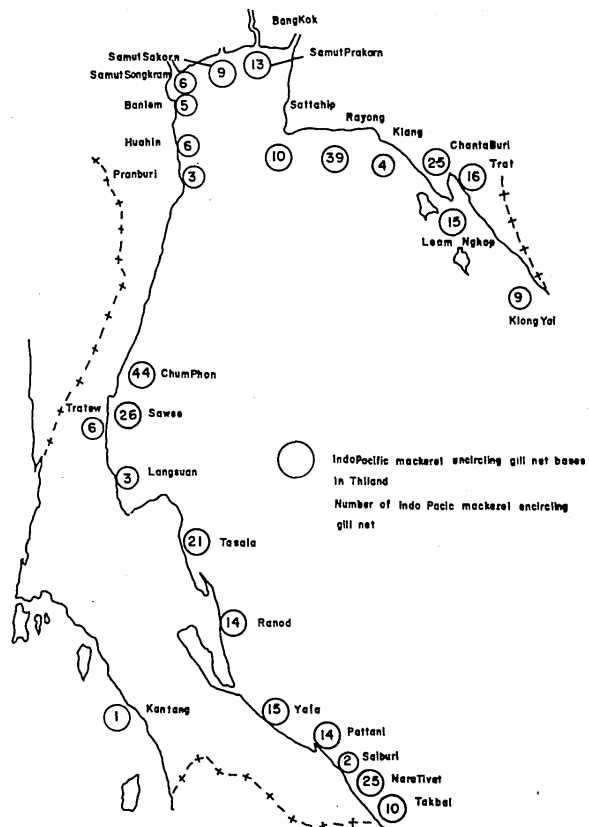

Major fishing bases of Indo-Pacific mackerel gill netters in Thailand

Fig. 9 Major fishing bases of Indo-Pacific mackerel gill netters in Thailand.

operated in the daytime. Once the fish school is found near the sea surface, the fishermen start to surround it with the net, beat the sea surface with wood sticks to frighten and chase the fish toward the mid-part of the net, and then haul up the net.

The encircling gill net with purse line is operated on dark nights. A fish school is located by finding luminous plankton which is stimulated by the seimming of fish through the water. From the circumstances of luminous plankton, the master fishermen predicts the species of fish, their swimming direction and speed, and the size of fish school, then the crew lay out the net. The fishing method is similar to that of one-boat purse seiners. In Fig. 9 the fishing bases of Indo-Pacific mackerel encircling gill netters are shown.

The fishing gear and method of encircling gill net with purse line are similar to those of one-boat purse seine. The size of fish caught by ordinary gill net is limited by the mesh size, while a wider size range of fish are caught with the gill net with purse line. However, it is troublesome to remove the fish from the gill net after a good catch.

Encircling gill net is suitable for small scale fishermen, though one-boat purse seine is recommended when enough capital is available for investment.

3. RECOMMENDATIONS FOR FUTURE FISHERIES IN THE SEAFDEC AREA

3.1 Skipjack pole and line fishery

According to calculations, some 2,000,000 tons of skipjack might be caught theoretically in a year, of which 1,200,000 – 1,400,000 tons are from the Pacific Ocean, 300,000 – 400,000 tons from the Indian Ocean and 200,000 – 500,000 tons from other areas. In the SEAFDEC area, the following are considered to be prosperous fishing grounds for skipjack: Indian Ocean, Sulu Sea, Celebes Sea, Jawa Sea, Banda Sea, West Pacific Ocean and South China Sea. The most promising fishery left in those areas seems to be skipjack pole and line fishery. The total catch of skipjack in the world is about 400,000 tons and the total catch of skipjack in Japan is 230,000 tons of which 90 percent is by pole and line and other 10 percent by purse seine and set net.

Japanese boats for skipjack pole and line fishery are specially designed and constructed for this purpose. However, in this area some accessories on the boatside should be modified and changes should be made in the water supply system. In skipjack pole and line fishery, the most troublesome problem is the supply of living bait. However, the supply of anchovy and other fish suitable for live bait of skipjack fishing in this area is no problem, though there still remains the problem of deciding the most suitable fish species for live bait. Live bait may be used not only to supply this fishery in Southeast Asian countries, but also for Japanese skipjack fishing boats.

The technique of handling the pole and line is not difficult. The important thing is to find and lure the fish school. There are several ways of studying the fishing technique; for example (1) sending trainees to Japan, (2) inviting experts from Japan, (3) learning Japanese techniques when supplying live bait to Japanese fishing boats,

and (4) constructing joint enterprises with Japan.

Frozen bonito exported from Thailand to Japan in 1971 amounted to 2,308 tons. During the period January to November 1971, frozen skipjack imported into Japan totalled 15,544 tons valued at 1,686,345,000 Yen. Of which 2,067 tons valued at 202,632,000 yen was from Thailand. During the same period, the total amount of dry bonito imported into Japan was 1,458 tons and that from Thailand being 307 tons (131,288,000 yen). In Thailand two bonito drying factories are operating, one is Eiko Food Co. Ltd. in Pranburi and the other Yun Thai Enterprise in Bangkok; their processing capacities for raw material are 10 and 6 tons per day, respectively.

3.2 Mechanized squid line fishery.

In Japan up to the present time squid fishing has usually been done by hand line from small boats. In recent years, however, larger fishing boats (150 – 500 tons) with mechanical fishing equipment have developed in this fishery, and this type of squid fishery is becoming one of the major deep-sea fisheries. At present, over 300 fishing boats of this type are operating in seas adjacent to Japan. In 1972 ten boats carried out successful fishing operations off California, U.S.A. and in waters off the coast of New Zealand. Some of them are carrying on trial fishing in these areas. In view of the above facts, research and development of the squid fishery is becoming necessary in the SEAFDEC area.

As mentioned above, squid fishery has so far been regarded as inshore or near shore fishery; mostly small boats were used for this fishery and time spent in cruising and fishing was only 2 or 3 hours. Recently, however, the possibility of deep sea squid fishery in the neighbouring waters of Japan has been recognized. Experimental fishing is carried out at depths as deep as 3,000 m in some fishing grounds, and as a result the fishing boats are becoming larger.

The squid resources in the world have been estimated to be approximately 5,000,000 tons while the total annual world catch of squid is only 1,000,000 tons. This means that about 4,000,000 tons of squid are unexploited.

At present squid is caught by hand lining in the south of Thailand near Narativat. The training vessel Paknam of the Training Department, SEAFDEC, has only done a little experimental fishing. However, from our limited experience, the following results were obtained:

- 1) A small size of fishing boat is better
- 2) In selecting artificial bait, yellow was the best for luring. Light blue was also good but red was poor. Bait covered with cotton twine had a better effect than that with a smooth plastic surface.

More detailed research should be done to determine the most effective bait and the most effective attracting lamps.

In 1970, the total catch of squid in Thailand was estimated to be 70,000 tons; this may be compared with the 18,583 tons total amount of frozen squid imported into Japan between January and November 1971.

3.3 Vertical long line fishery

Demersal fish on banks and edges of the continental shelf have not yet been exploited by trawling, gill netting and bottom lining. Vertical long line is thought to be the most effective fishing gear to use on a rocky bottom, coral bottom or steeply sloped bottom. Fish living in those areas include *Prinstipomoides* spp., *Aphareus* spp., *Lutjanus* spp., *Gymnocranius* spp., *Caragidal* spp., *Pseudopriacanthus* spp., *Priacanthus* spp., *Argyrospo* spp., *Epinephelus* spp., etc. The following may prove to be promising fishing grounds: the South China Sea, Macclesfield Bank, Philippine waters, the west coast of Malay Peninsula, around the Andaman Islands, the Gulf of Bengal, and around the Nicobar Islands.

Vertical long line is a newly developed gear and is operated by hand, man-powered reel, or motor-powered reel. A main line with a sinker of 0.7 to 1.5 kg attached is lowered vertically to a desired depth. 10 to 12 branches, each of which has a hook, are fastened to the main line at regular intervals of 90 to 100 cm. Squid, sardine and small demersal fish are used as bait. Squid seems to be most effective bait for vertical long lining in deep waters. The fish finder has a most important role in this fishery. Exploitable fish schools are usually found on the brink of the continental shelf. During operation the fishing boat should be kept just above the fish school. For small boats, the spanker and sea anchor are useful to keep the boat in the desired direction.

3.4 Mid-water trawl fishery

Mid-water trawling may be effective for catching squid and white shrimp.

3.5 Philippine lift net fishery

In general surrounding nets such as purse seine, ring net and lampara net are the most effective fishing gear for small size pelagic fish such as anchovy and sardine. However, this type of fishing gear is not always suitable for small scale fishery. In Japan, the stick held lift net is commonly used for catching saury, horse mackerel and anchovy, and the results seem to be successful. However, this type of gear has not yet been proved effective in the SEAFDEC area because of the different environmental factors involved and the different species of fish. Considering the above, the Philippine type lift net is recommended for catching sardine, anchovy and live bait which is always necessary for the skipjack pole and line fishery, because this type of fishing gear which has been developed in Philippine waters seems to be most suitable in this area.

3.6 Jellyfish fishery

In recent years the demand for dry salted jellyfish has increased and jellyfish is another resource not yet fully exploited in the area. The major fishing gear for jellyfish is the scoop net, while the bamboo stake is also in use. The following are suggested as fishing gear which might be used in future.

- 1) Bamboo fence
- 2) Bamboo stake
- 3) Small size two-boat type mid-water trawl.

PART III RECORD OF DISCUSSION

THE PELAGIC RESOURCES

Discussion Leader: I. Ronquillo

Rapporteur: T. Senta

Principal Papers: S-23, 24, 28, 29 Ref-5

Related Papers: S-6, 13, 17, 21, 15 Ref-2, 7, 8, 11

Papers submitted were grouped into four categories according to the contents: comprehensive reports, regional information, methodological and environmental reports. During the discussion the following points were highlighted.

1. Existing Knowledge and Problems

1.1 Important pelagic fisheries resources in the region

Chub mackerel, Spanish mackerel, roundscad and anchovies constitute the most important part of the pelagic fisheries resources. Some stocks in particular areas have been almost fully exploited especially *Rastrelliger* sp. in the Gulf of Thailand, but in other offshore areas, other stocks offer good possibility for expansion.

It was realized that in certain countries large tuna species such as yellowfin and bigeye were heavily exploited. The seminar noted the possibilities of expansion and development of fisheries for skipjack and small tuna species.

Pelagic shrimps, *Acetes* spp. form important fisheries in some areas of inshore waters in the region.

Of potential importance also are the small-sized fishes occurring in great abundance e.g. *Caesio*-like fish and myctophids which may be good material for fish-meal industry.

1.2 Catch statistics and nomenclature

Catch statistics by species are now available in some member countries. However, there is great difficulty in comparing catch statistics between countries in terms of species categories established in national statistical species classification. This was particularly realized for tuna and tuna-like species. The fish identification sheet to be distributed by FAO will help in resolving this problem.

1.3 Biological knowledge

Intensive studies on fisheries biology have been carried out on chub mackerel in the Gulf of Thailand, including catch statistics, size composition, tagging experiments, study of early life history and racial study. Based on these studies, stock assessment was undertaken, and the existence of one age group and two sub-populations in the Gulf was determined. Cyclical fluctuation in the catch were observed both in the Gulf of Thailand and Straits of Malacca.

However, only little knowledge has been accumulated for most other species in the region. One important problem is the location of roundscad spawning grounds in Philippine waters.

Detailed regional distribution of each variety of so-called small-tunas is not yet known.

1.4 Suitable fishing gear

The Philippine fishermen are using large bamboo rafts to attract deep-swimming tunas and other pelagic fish. Handline fishing for deep-swimming yellowfin tuna, 50–60 kg. in weight, appears to be more suitable for the area when the capital needed for long-line operation is taken into consideration.

1.5 Market demand, transportation and preservation

Fishes with dark meat such as bonito and frigate mackerel are often not esteemed at local markets. Due to shortage of ice the fish caught often deteriorate before reaching the market. With the introduction of new fishing methods and new equipment, the methods of preserving fish in the traditional type of fishing boats becomes unsuitable.

2. Action Required and Future Needs

Taking the above mentioned circumstances into consideration the Seminar agreed on the following actions and future needs.

- 2.1 Organize a working party for the study of catch statistics among member countries.
- 2.2 Organize a joint project for the investigation of chub mackerel.
- 2.3 Organize a program for the survey on live-bait necessary for skipjack fishing.
- 2.4 The following studies on tuna resources and its fishery should be undertaken:
 - i) Studies on stock assessment carried out in conjunction with studies on suitable fishing gear and fishing methods for the exploitation of small tuna species.
 - ii) The development of local markets for small tuna.
 - iii) Research vessels in the region are recommended to include in their regular programs observations on number and size of fish schools. Species may be determined by experimental trolling.
- 2.5 Collection of biological knowledge of roundscad and Spanish mackerel especially on reproduction and races.
- 2.6 Study on the mechanism of fluctuation in the abundance and on fish school behavior connected with environmental factors is of special importance for pelagic species.
- 2.7 The use of acoustic methods for the detection and abundance estimation of pelagic species wherever possible during exploratory fishing surveys.
- 2.8 Development of locally suited fishing gear and methods, and improvement of preservation of catch.
- 2.9 Utilization of fishes at present non-marketable through development of processing technique.
- 2.10 Study on the biology of milk-fish in the sea, especially the mechanism of annual fluctuation in

the abundance of adults and juveniles and their migration routes.

- 2.11 Development of suitable gear for the exploitation of pelagic shrimps in offshore and inshore waters.

THE DEMERSAL RESOURCES

Discussion Leader: D. Pathansali

Rapporteur: Tan Sen Min

Principal Papers: S-1, 2, 10, 12, 15, 18, Ref-1, 2, 7, 14
19, 26

Related Papers: S-4, 5, 7, 8, 11, 14, 16,
17, 27, 31.

Discussion on the papers submitted was directed along the following lines: national, comprehensive, research and fishery statistics. The discussion reviewed the demersal resources in the region with particular reference to:

- a) the status of demersal fisheries in inshore and offshore waters.
- b) assessment of the potential demersal fish resources.
- c) research and management.

Based on the comments of the discussion leader and the ensuing discussion on these main areas, the following problems and gaps were identified.

1. Review of Existing Information and Problems

- A. The status of demersal fisheries in inshore and offshore waters.

There has been tremendous development in demersal fisheries, especially by trawling, in most countries. While inshore demersal fish resources are being intensively exploited and in some instances even over exploited, the offshore fisheries are just being developed. However, lack of essential information on potential resource and good fishing grounds has retarded offshore fisheries development.

The rapid and uncontrolled increase in the number of mini-trawlers, due to the conversion from traditional fishing methods to trawling, has led to competition between these and larger trawlers, which are now being replaced for economic reasons.

There is, therefore, an urgent need for management and conservation measures at country level.

- B. Assessment of the Potential Demersal Fish Resources

The lack of uniform and reliable fishery statistics has impeded the evaluation of the resource potential. Although the assessments that have been made on the potential demersal fish resources indicate its overall magnitude, there is a need for improvement as more information and data became available.

- C. Research and Management

Research activities carried out varied according to the priorities of the various countries, though the problems were similar. The Marine Fisheries Research Department of SEAFDEC, on the other hand, had directed its research activities along its assigned functions primarily to assess the potential resource, determine suitable fishing grounds,

establish the feasibility of commercial fishing, develop new fisheries in untrawlable grounds and evaluate environmental factors.

2. Future Needs

- 2.1 To collaborate and coordinate research by member countries and SEAFDEC and to standardize research procedures and methods, to avoid duplication thus utilizing fully the available resources and facilities.
- 2.2 To assess demersal fish resources taking into consideration seasonal and spatial variations and the effect of environment.
- 2.3 To monitor the fish resources, particularly where statistics are deficient, to assess the trends in catch rates in relation to fishing intensity.
- 2.4 To include economic aspects in fisheries research so as to provide information necessary for the development of offshore fisheries.
- 2.5 To identify the extent of trawl development, especially where expansion to other areas is not possible and to determine the limits of development so as to prevent problems of over-fishing and over-development.
- 2.6 To develop fishing in offshore areas by trawl and other gear, particularly long-lines and vertical-lines.
- 2.7 To intensify studies on the qualitative aspects of the resources such as species composition and biology essential for population assessments currently being undertaken in conjunction with studies on environmental factors.
- 2.8 To obtain better data on trash fish as differentiated by fishermen.
- 2.9 As fisheries statistics are of great importance and indispensable to research, management and country development programs, they should provide the basic types of required information.
- 2.10 Though there has been some development in offshore demersal fisheries there is yet little information on commercial fishing statistics. Such information is essential in the planning of offshore fisheries development and in the assessment of resources and potential yields.

3. Action Required

Arising out of the discussions on existing information, problems and needs, the Seminar agreed that the following actions are required:

- 3.1 On Management:
 - a) Action on management problems should be initiated in the early stages of the development of new fisheries. Such action might take the form of limiting the rate of expansion until the potential yield is adequately known. On partially or intensively developed fisheries management measures should be identified and enforced as appropriate.
 - b) To replace smaller trawl vessels fishing in inshore water by larger ones, by providing incentives, if necessary, to exploit offshore fisheries.

- 3.2 On Research:
- a) To promote collaboration in research amongst the countries.
 - b) To promote cooperative research projects and programs especially exploratory and monitoring surveys.
 - c) To promote and establish uniform and reliable statistical systems for research, management and development needs.
 - d) To establish an effective mechanism for the exchange of research results and other related information between interested institutions, both in member countries and SEAFDEC.
- 3.3 On Development:
- a) To develop offshore fisheries, both demersal and pelagic, because of the limited potential for further expansion fisheries.
 - b) To develop new methods of fishing for unexploited resources in untrawlable gears.
 - c) To undertake studies on the comparative efficiency of traditional fishing gears.
 - d) To improve icing and handling practices and storage facilities aboard fishing vessels to enhance the value of the catch.

OTHER RESOURCES INCLUDING AQUACULTURE AND MINOR SEA PRODUCTS

Discussion Leader: K. Kuronuma

Rapporteur: S. Mito

Principal Paper: Ref-13

Related Papers: S-3, 30, 31 Ref-2a, 10, 11, 12, 15, 16, 35

Discussion on other resources including aquaculture and minor sea products was conducted along the lines of national interests and research needs. A summary of relevant papers was made by the discussion leader while identification of other resources and minor sea products was given by the rapporteur. The discussion leader requested the participants to make constructive suggestions regarding the program of operation of the Aquaculture Department of SEAFDEC, soon to be established.

I. Review of Existing Information and Problems

A. Present status of other resources and minor sea products

1. Said resources and products were classified into 2 categories:
 - a) Prawn, shrimps, crabs, lobsters, sea turtles, squid, cuttlefish, octopus, oysters, mussels, cockles, sea cucumbers, jelly fish and seaweeds were considered as food resources.
 - b) Sea snakes, aquarium fish, pearl, decorative shells, corals, sea urchins, star fish, sponge and several other kinds of seaweeds were identified as ornamental and industrial resources.
2. The prawn catch in the region is increasing. However,

the supply of natural fry for culture is decreasing most areas.

3. The marked increase in the landings of squid and cuttlefish was mentioned. However, the decreasing size of these organisms was also pointed out.
4. Not much work has been done on organisms other than prawn, shrimp, squid and cuttlefish.

B. Aquaculture

1. Existing knowledge could be obtained from the reports of the IPFC Symposium on Coastal Aquaculture, (Bangkok, 1970), the FAO World Scientific Conference on the Biology and Culture of Shrimps and Prawns (Mexico, 1967) and from various aquaculture journals.
2. It was pointed out that the fish productivity in pond is related to the geological nature of the soil and other natural and sociological conditions of the region.
3. Oyster culture has been established in some areas and is being introduced in other areas.
4. The methods of fish culture in cagernets and fish pens are also being applied in some areas of the region.

C. Research Needs

1. Biological and ecological studies on squid and cuttlefish were emphasized in connection with the rapid increase of fishing efforts.
2. Biological studies and stock assessment on prawn and shrimp should be carried out in detail for the development of fisheries and aquaculture.
3. The survey on the location and abundance of eel elver in the region was emphasized.
4. Research on freshwater fish culture is needed.

II. Action Required

1. Inland fisheries and freshwater aquaculture should be developed.
2. Training in aquaculture techniques should be given to personnel at various vocational levels to improve aquaculture standards.
3. Instead of depending on experts from outside the region, the development of expertise through training and exchange of experts within the region should be considered.
4. The program of the proposed Aquaculture Department should cover the expressed needs of member countries.
5. In connection with FAO World Technical Conference of Aquaculture scheduled to be held in 1975 or 1976, it was recommended that a SEAFDEC Aquaculture Seminar be held coinciding with the inauguration of the new Aquaculture Department in Panay Island, Philippines in 1974. Experts attending the Seminar should make an observation in 1974. Experts attending the Seminar should make an observation tour of aquaculture in the region before the Seminar.
6. Bibliographic work should be undertaken by the Aquaculture Department to facilitate the exchange of the latest information on this field of research.

ECONOMIC AND SOCIAL ASPECTS OF THE RESOURCES

Discussion Leaders: S. Iwakiri/I. Ronquillo
Rapporteur: Hooi Kok Kuang

Principal Papers: S-24, 27, 34 Ref-3, 7, 8, 10
Related Papers: S-30 Ref-6, 9, 11, 12, 13

4. Better utilization of "trash" fish should be considered.
5. Fishery statistics must be developed to guide administrators in the effective planning of fisheries development programs.
6. Outmoded fishery laws should be revised to suit present conditions and governments should be urged to improve the capacity of implementing such laws.

The Discussion Leader outlined the economic and social aspects of the development of fisheries in the region as a guide for discussion. The outline and the subsequent discussion are summarized below:

I. Review of Existing Information

1. While individual countries were aware of their priorities in fisheries development, some co-ordinated action seemed necessary for the optimum development of the fishery industry in the region.
2. Fish is second only to rice as food in member countries. In recent years, fishermen have tended to concentrate on highly priced fishery products which are also foreign currency earners.
3. As the economic level of fishermen in member countries is generally low, it is now clear that administrators have to think in socio-economic terms to increase fishermen's income and improve their living standards.
4. Recently, there has been tremendous investment in trawl fisheries in almost all member countries. However, the pelagic fishery has yet to attain this level of development.
5. Aquaculture is becoming more and more important in fisheries development planning.
6. The development of biological and technical expertise among fishery personnel in government and other institutions is recognised.
7. It is noted that fishing ports, servicing facilities and infrastructures are wanting in some countries.

II. Major Problems Identified

1. Poor credit and marketing facilities and inviability of cooperatives have collectively hindered the social and economic advancement of fishermen.
2. The shortage of trained personnel in fishery technology and techniques of fish culture is a major problem. The communications gap between fisheries personnel and fishermen is also noted.
3. In most countries, there is a problem of too many fishermen, leading to competition in gear and grounds. Singapore, however, experiences the unique problem of a shortage of fishermen.

III. Action Required

1. Improvement of credit facilities for artisanal fishermen, and the provision of relevant infrastructures for fisheries enterprise.
2. Marketing procedure, including transportation of perishable fishery products, should be recognised in favour of the fishermen.
3. Training in the use of modern fishing techniques and gears in offshore fisheries and in the handling and processing of fishery products is necessary.

PART IV RECOMMENDATIONS

Discussion Leader: I. Ronquillo
Rapporteur: F.Y. Chen and A. Sribhibhadh

Taking into consideration the gaps of knowledge and problems identified in the preceding four sessions, the Seminar discussed future needs and action required, and made the following recommendations.

Recommendation 1: Statistics

Recognizing the real need for basic statistical information necessary for national fisheries development planning and its successful implementation, and the general lack of trained personnel and adequate support to undertake this task, the Seminar recommends that urgent and timely attention be given to national fisheries statistical systems by the Governments of the member countries, and further recommends that SEAFDEC establish a coordinating mechanism such as a working group consisting of responsible workers in the field of fisheries statistics from all member countries to complement the activities of the existing IPFC/IOFC Joint Working Party of Experts on Western Pacific and Indian Ocean Fishery Statistics in implementing the program within the area.

Recommendation 2: Monitoring

For the proper evaluation of the status of the fisheries resources and their potential for development and/or management, it is essential to complement the collection of statistical data by biological monitoring of the major fish stocks on a regular basis with studies on the species composition of the catches including trash fish and on length composition as a minimum basic requirement.

It is realized that some member countries have been undertaking monitoring surveys on demersal resources with research vessels for a number of years and that the results have been most useful. The Seminar, therefore, recommends that such monitoring surveys be continued and that SEAFDEC promote these activities through further cruises of its vessels and coordination of the national programs of member countries.

Recommendation 3: Exploratory survey

It is appreciated that the exploratory fishing surveys, carried out by SEAFDEC and some member countries, have provided useful results and improved knowledge of the resources available for fisheries development. The Seminar recommends that such surveys be continued and expanded wherever possible. Increased attention should be given to the wide range study of the distribution and abundance of pelagic resources, particularly possibilities for further development; in addition, studies on demersal resources in untrawlable fishing grounds should be expanded. It is further recommended that modern acoustic techniques be used for the detection and abundance estimation of fish during these surveys and realized that trained personnel will be needed for that purpose.

Recommendation 4: Pelagic resources

Realizing the possibility of developing and expanding fisheries on certain pelagic resources, the Seminar recommends that SEAFDEC and member countries should promote the application of modern pelagic gear already existing in the region (e.g. pelagic trawl and purse seine).

Recommendation 5: Comparison of gear

Realizing that a considerable number of types of local traditional fishing gear may need only slight modifications to reach a maximum level of efficiency, and taking note of a related resolution by IPFC, the Seminar recommends that SEAFDEC, in collaboration with the member governments, organize a comparative study on the efficiency of the most promising local traditional gear within the area.

Recommendation 6: Management

Noting the rapid and welcome expansion of many fisheries in the region, the Seminar emphasized that this had already resulted in some stocks becoming fully exploited, and others were likely to become fully exploited in the near future. Unless suitable action is taken, this will result in economic waste, social distress and damage to the resource. The Seminar, therefore, recommends that Governments give early and urgent attention to the possible need for management action including the discouragement of over expansion and the diversion of fishing to less heavily exploited resources, e.g. to some offshore stocks. The Seminar further noted that to an increasing extent some stocks are being exploited by more than one country. Management of these stocks requires close international coordination. The Seminar recommends that these needs for coordinated international action be drawn to the attention of member governments and relevant international bodies such as IPFC.

Recommendation 7: Aquaculture

In view of the importance of aquaculture and the need to obtain future information on the status of aquaculture research and progress in the region, it is recommended that a SEAFDEC Aquaculture Seminar be held in conjunction with the establishment of the new Aquaculture Department of SEAFDEC in 1974, and it is further recommended that regional experts attending the proposed Seminar make a study tour in the region prior to it. The proposed Seminar will also be in preparation for the FAO world Technical conference on Aquaculture scheduled to be held in 1975 or 1976.

Recommendation 8: Future seminars

Noting the value of the present Seminar in bringing together fishery workers from all member countries, and the fruitful discussions that resulted, the Seminar recommends that arrangements be made by SEAFDEC for further seminars on specialized topics of regional interest of which the proposed seminar on Aquaculture might be the first. Another subject for a future seminar which

deserved special attention was the survey and evaluation of natural freshwater fishery resources.

The Seminar realized that the implementation of most of these recommendations will have a bearing on the work of both SEAFDEC and the FAO/UNDP South China Sea Fisheries Development and Coordinating Programme, and it therefore urges that SEAFDEC and the Programme collaborate as closely as possible for the benefit of fisheries development and rational utilization of the living resources in the South China Sea.

ANNEXES

Annex 1

LIST OF PARTICIPANTS

JAPAN:

Dr. T. Aoyama
Seikai Regional Fisheries Research
Laboratory
Nagasaki
Japan

Prof. T. Iwakiri
Kagoshima University
Kagoshima
Japan

Dr. S. Kikawa
Far Sea Fisheries Research Laboratory
Shizuoka Prefecture
Japan

Dr. K. Kurogane
Tokai Regional Fisheries Research
Laboratory
Tokyo
Japan

Dr. K. Kuronuma
c/o Fisheries Agency
Tokyo
Japan

MALAYSIA:

Mr. D. Pathansali
Director
Fisheries Research Institute
Glucor, Penang
Malaysia

Mr. M.S.S.A. Latiff
Senior Research Officer
Kuala Lumpur
Malaysia

Mr. Chin Phui Kong
State Fisheries Officer
Sabah
Malaysia

Mr. Mohd. Yusof bin Yahyah
Permanent Secretary to the Ministry of
Agriculture and Fisheries
Sabah, Malaysia

Mr. Ong Kee Bian
State Fisheries Officer
Sarawak, Malaysia

**REPUBLIC
OF THE
PHILIPPINES:**

Mr. Felix R. Gonzales
Director
Bureau of Fisheries
Manila, Philippines

Mr. Pedro Acosta
Bureau of Fisheries
Manila, Philippines

Prof. I. Ronquillo
Director of Research Division
Bureau of Fisheries
Manila, Philippines

**REPUBLIC
OF
SINGAPORE:**

Mr. Hooi Kok Kuang
Senior Primary Production Officer
Ministry of National Development
Singapore

Mr. Seow Pau Chern
Senior Primary Production Officer
Ministry of National Development
Singapore

THAILAND:

Mr. Samran Ritragasa
Senior Fisheries Officer
Department of Fisheries
Bangkok

Mr. Damri Somjaiwong
Fisheries Technical Officer
Department of Fisheries
Bangkok

Mr. Manas Potaros
Research Scientist
Department of Fisheries
Bangkok

Mr. Virach Jarusombat
Research Scientist
Exploratory Fishing Unit
Department of Fisheries
Bangkok

Mr. Chumpol Nakaluksana
Statistician
Department of Fisheries
Bangkok

**REPUBLIC
OF VIETNAM:**

Mr. Le Van Dang
Deputy Director
Directorate of Fisheries
Saigon, Republic of Vietnam

Mr. Ha Khac Chu
Administrator
Offshore Development Programme
Institute
Directorate of Fisheries
Saigon, Republic of Vietnam

F.A.O.:	<p>Dr. J. A. Gulland Chief Fishery Statistics & Economic Data Branch Fishery Economics and Institutions Division FAO, Rome</p> <p>Dr. D. Sahrhage Chief Marine Biology & Environment Branch Fishery Resources Division FAO, Rome</p> <p>Mr. Arthur G. Woodland Programme Leader South China Sea Fisheries Development and Coordinating Programme FAO, Rome</p> <p>Mr. D. D. Tapiador Regional Fisheries Officer FAO, Bangkok</p> <p>Dr. T. Yamamoto UNDP/FAO Country Programme Indonesia</p> <p>Dr. S. Kume Consultant to South China Sea Fisheries Development and Coordinating Programme FAO, Rome</p>	<p>Ministry of Agriculture and Cooperatives Bangkok</p> <p>Mr. Umpol Pongsuwan Director Marine Fisheries Laboratory Department of Fisheries Bangkok</p> <p>SEAFDEC Training Department:</p> <p>Dr. Arporn Sribhibhadh Chief Training Department Southeast Asian Fisheries Development Center Pom Phrachulchomklao Samutprakarn</p> <p>Dr. Shigeaki Shindo Deputy Chief Training Department</p> <p>Mr. Y. Nishioka Fishing Technology Instructor Training Department</p> <p>Mr. T. Yamazaki Fishing Technology Instructor Training Department</p> <p>Mr. Paisal Katanyuwong Fishing Technology Instructor</p>
NATIONAL TAIWAN UNIVERSITY:	<p>Dr. Hsi-Chiang Liu Chief Demersal Resources Research Center Institute of Oceanography National Taiwan University Taipei, Taiwan</p>	<p>SEAFDEC Research Department:</p> <p>Mr. Chen Foo-Yan Chief Marine Fisheries Research Department Southeast Asian Fisheries Development Center Changi Point, Singapore</p>
CHULALONG- KORN UNIVERSITY:	<p>Dr. Taweesakdhi Piyakarn Head Marine Science Department Chulalongkorn University Bangkok</p>	<p>Dr. Satoshi Mito Deputy Chief Marine Fisheries Research Department</p> <p>Dr. Tetsushi Senta Fisheries Resources Section Marine Fisheries Research Department</p>
KASETSART UNIVERSITY:	<p>Prof. Mek Boonbrahm Dean College of Fisheries Kasetsart University Bangkhen, Bangkok</p>	<p>Mr. Tan Sen Min Fisheries Resources Section Marine Fisheries Research Department</p> <p>Dr. Otohiko Suzuki Fishing Ground Development Section Marine Fisheries Research Department</p>
INVITED EXPERTS:	<p>Dr. S. W. Ling Apt. Q Phayathai Court 65/2 Phayathai Road Bangkok</p> <p>Mr. Toshifumi Sakurai Colombo Plant Expert Department of Fisheries</p>	<p>Dr. Akihiko Shirota Ocean Research Section Marine Fisheries Research Department</p>

SEAFDEC
Proposed
Aquaculture
Department:

Mr. Pedro Acosta
Bureau of Fisheries
Department of Agriculture and Natural
Resources
Intramuros, Manila

AUDITORS:

Mr. Ng Ket Fah
Manager
Tung Hai Fishing Co., Ltd.
P.O. Box 1233, Sandakan
Sanah, East Malaysia

Mr. Chan Sai Kay
Director
Tung Hai Fishing Sdn. Bhd.
P.O. Box 1233, Sandakan
Sabah, East Malaysia

Miss Reiko Kuronuma
Tokyo Medical and Dental University
Tokyo, Japan

Dr. Pricha Sommani
College of Fisheries
Kasetsart University
Bangkok

Mrs. Supap Monkolprasit
Faculty of Fisheries
Kasetsart University
Bangkok

Mrs. Khanjanapaj Lewmanomont
Faculty of Fisheries
Kasetsart University
Bangkok

Mr. Kasemsant Chala Yondeja
Department of Fisheries
Ministry of Agriculture and Cooperatives
Rajdamnern Avenue, Bangkok

Dr. Suraphol Sudara
Lecturer
Department of Marine Science
Chulalongkorn University
Bangkok

Miss Wimon Arrunyagasemsuke
Instructor
Department of Marine Science
Chulalongkorn University
Bangkok

SEMINAR

Captain Samarom Bunnag, R.T.N.

SECRETARIAT:

Chief of General Affairs Division
Training Department
Southeast Asian Fisheries Development
Center
Pom Phrachulchomklao
Samutprakarn

Mr. Paisal Katanyuwong
Mrs. Tessa Sreesangkom
Mr. Apiwat Thamakasorn
Mr. Veera Seedokbuab
Miss Vunpenn Sunthorntham
Mr. Prakrit Meechai
Miss Renoo Sookmark
Miss Nualla-or Pradit
Mr. Vibul Boonyatorn
Mr. Issara Sricha-oom

REPORT TO H.E. THE MINISTER OF AGRICULTURE
AND COOPERATIVES
GIVEN BY THE SECRETARY-GENERAL OF SEAFDEC
ON THE OCCASION OF THE OPENING OF
THE TECHNICAL SEMINAR ON SOUTH CHINA SEA FISHERIES RESOURCES
Chulalongkorn University, May 21 – 25, 1973

Excellency,

On behalf of the participants in the Technical Seminar on South China Sea Fisheries Resources and the officials of the Southeast Asian Fisheries Development Center Secretariat, I wish to express our sincere appreciation and profound gratitude for the honour Your Excellency confer upon us by presiding over the Opening Ceremony of this Seminar today.

On this occasion, I would like to take the opportunity to report briefly on the establishment and the activities of the Center.

Having recognized the vital importance of promoting fisheries development in Southeast Asia to meet the urgent need of increasing food supply and of improving nutritional standards, especially of increasing the production of animal protein in the region, the First Ministerial Conference for the Economic Development of Southeast Asia, held in Tokyo in April 1966, proposed the establishment of the Southeast Asian Fisheries Development Center (called in short SEAFDEC). Subsequently, the Center was established in 1968 under an Agreement signed by six countries, namely Japan, Malaysia, Philippines, Singapore, Thailand and the Republic of Vietnam.

It is one of the first concrete regional projects resulting from a recommendation of the Ministerial Conference.

The main purpose of the Center is to enhance and promote fisheries development through mutual efforts among its Member Countries and other non-Member Countries, as well as interested organizations. The anticipated contribution of the Center to regional fisheries development includes the development of skilled and experienced manpower in the region for the primary sector of the fishing industry, in particular, deep-sea fishing enterprise, the gain of knowledge concerning the status of fisheries resources and fishing grounds in the waters surrounding and adjacent to the Southeast Asian countries.

Another major contribution from the Center is the development of suitable and economical types of fishing gear and methods for effective harvesting of the said resources.

The Center operates two Departments at present. The Training Department in Thailand offers two-year training courses in navigation, seamanship, deep-sea fishing, and marine engineering. The Research Department in Singapore has a one-year training course in marine fisheries research with particular emphasis on the study of fish stocks in the South China Sea and the oceanography of the fishing grounds. At the moment, 21 trainees from Member Countries are attending the courses on navigation and fishing at the Training Department while 6 research trainees are in the Research Department. In addition, the Center is establishing a third Department in the Philippines dealing with the various aspects of aquaculture with major emphasis on brackish and coastal aquaculture. It is expected that this Department will contribute significantly to the aquaculture development in the region.

While SEAFDEC, being a young organization, is pursuing its objectives to develop fisheries on a regional basis, the various Southeast Asian countries are also continuing their own national programs for the development of national fisheries either through national, regional and international funding available for the purpose. In view of this, the Indo-Pacific Fisheries Council proposed the setting up of the South China Sea Fisheries Development and Coordinating Programme under the sponsorship of UNDP, and suggested at its Fourteenth Session that SEAFDEC organize a Technical Seminar on Fisheries Resources in region. Last June, the SEAFDEC council, at its Fifth Meeting in Bangkok, approved a budget for holding such a Seminar. In this connection, the Center is indebted to the Government of Japan for providing essential financial assistance and the services of experts for the Seminar. Without this generous assistance, it would hardly be possible to hold the Seminar at this time.

The objectives of the Seminar are to review and consolidate the existing knowledge of fisheries resources in the South China Sea and their economic and social aspects, and to recommend steps necessary for further required assessment and evaluation to form a basis for the planned development of national fisheries and the management of the exploited resources, i.e. (a) reviewing existing information, (b) identifying gaps of knowledge, and (c) recommending action.

With kind assistance from the Department of Fisheries, Thailand, the Food and Agriculture Organization of the United Nations, and, Chulalongkorn University, the Center is holding the Seminar from 21 – 25 May 1973.

I feel confident, that the outcome of this Seminar will benefit, in particular, the development planning of national fisheries in the countries of the region.

May I now invite Your Excellency to officially open this Technical Seminar to mark another regional cooperative effort in contributing to the economic development of Southeast Asia.

ADDRESS OF
H.E. THE MINISTER OF AGRICULTURE AND COOPERATIVES
GIVEN AT THE OPENING CEREMONY
OF THE TECHNICAL SEMINAR ON SOUTH CHINA SEA FISHERIES RESOURCES
Chulalongkorn University, May 21, 1973

Excellencies, Distinguished Guests, Ladies and Gentlemen:

It is with great pleasure that I welcome you to the Technical Seminar on South China Sea Fisheries Resources being sponsored by the Southeast Asian Fisheries Development Center.

I am gratified to learn from the report which the Secretary-General of the Center has just given, of the remarkable progress being made at the Center's Training Department in Thailand and its Research Department in Singapore as well as the benefits which are expected to follow the establishment of its Aquaculture Department in the Philippines.

There is no need for me to enlarge here upon the significance of fisheries resources in the economic development of the countries in this region, apart from mentioning that these resources serve as a source of protein for expanding populations, provide employment opportunities, and are also valuable export commodities which will bring much needed foreign exchange to the respective countries.

For these reasons, the Government of Thailand has accorded high priority to the highsea fisheries development program in our national economic and social development plan. Besides well-trained and skilled personnel, modern fishing technology and equipment, the implementation of this program requires good knowledge of the available resources.

As this Seminar aims to bring to light the magnitude and potential of the various fisheries resources in the region, its outcome will not only give a better understanding of the resources and their economic and social aspects but will also provide an essential basis for planning national fisheries development.

Nothing that the Southeast Asian Fisheries Development Center is the first regional project that has been established on the recommendation of the Ministerial Conference for the Economic Development of Southeast Asia, I wish to state that the Government of Thailand has extended assistance and will continue to provide support to this undertaking firmly believing in the spirit of regional cooperation.

At this time, I would like to take the opportunity to thank the Government of Japan for its generous provision of financial assistance and the participation of experts, as reported by the Secretary-General, which has made it possible to hold this Seminar.

I would like also to express our gratitude to the authorities of Chulalongkorn University for allowing us to make use of their excellent facilities and to meet in these pleasant surroundings.

It is now an auspicious time and I, therefore, declare open the Technical Seminar on South China Sea Fisheries Resources. May your deliberations be successful and to the benefit of all countries in the region.

LIST OF PAPERS

Subject Papers		
SEAFDEC/SCS. 73: S-11	Yamamoto, T.	Current status of fisheries development in South China Sea area
2	Yamamoto, T.	Fishery statistics required for the stock assessment of fisheries resources in South China Sea area
3	Seow, P.C. & Tay, G.	Preliminary observations on the utilization of pig-dung effluent for fish production
4	Suzuki, O.	Fishing condition and its oceanographic interpretation in bottom longline fishing grounds
5	Suzuki, O.	A rational survey method for evaluation of trawl fishing ground
6	Suzuki, O. & Hooi, K.K.	Behaviour of the warm-water mass along the east coast of the Malay Peninsula
7	Suzuki, O.	Fish school structure of red snapper and bigeye snapper in the South China Sea
8	Shirota, A. & Ratanachote, A.	Preliminary observation on the distribution and catch of the shovel-nosed lobster, <i>Thenus orientalis</i> Lund in South China Sea
9	Primary Production Department, Singapore	Status of fisheries development in Singapore (Country Report)
10	Senta, T., Tan, S.M. and Lim, P.Y.	Results of the experimental trawl in the South China Sea by R/V CHANGI in the years 1970 to 1972
11	Senta, T. & Peny, C.C.	Studies on the feeding habits of red snapper, <i>Lutianus sanguineus</i> and <i>L. seabrae</i>
12	Senta, T. & Tan, S.M.	Trawl fishing grounds in North Andaman Sea
13	Lim, L.C.	Preliminary report on the distribution of chaetognaths in the southern part of the South China Sea
14	Shirota, A.	Some consideration on the relationship between environmental factors and the distribution of fisheries resources in the South China Sea and the Andaman Sea
15	Senta, T., Miyata, C. & Tan, S.M.	Demersal fish resources in untrawlable waters, viewed through vertical-line fishing
16	Senta, T., Kungvankij, P. & Tan, S.M.,	Biological study of red snapper, <i>Lutianus sanguineus</i>
17	Shirota, A.	Records of echo-sounder tracing as guide to locate and evaluate good fishing grounds
18	Chen Foo Yan & S. Mito	Current status of research activities of the Marine Fisheries Research Department, SEAFDEC
19	Hooi, K.K.	A study of the catch data of the Jurong in the South China Sea in 1971 and 1972
20	Department of Fisheries	Country Report – Thailand
21	Shirota, A.	Brief note on the relationship of scattering layer and some hydrobiological factors
22	Department of Fisheries	Country Report – Malaysia
23	Bureau of Fisheries	Country Report – Philippines
24	Bureau of Fisheries	A plan for the development of sea fisheries in the Philippines
25	Flores, E.C.	Harvesting of marine resources in the Philippines
26	Liu, H.C.	The demersal resources of the South China Sea
27	Yamamoto, T.	Problems other than fisheries resources in the South China Sea
38	Kikawa, S.	Tuna and tuna-like fish resources in the South China Sea and its adjacent waters

SEAFDEC/SCS:73: S-29	Kurogane, K.	Some considerations of research and study on pelagic fishery resources
30	Caces-Borja, P.	The seaweed industry of the Philippines
31	Aoyama, T.	Research on demersal fishes on the continental slope in the northern part of the South China Sea; the cruise result of R/V Kaiyo-Maru
32	Le Van Dang	Fisheries Resources of Vietnam (Country Report)
33	Ha-Khac-Chu	Fisheries of Vietnam
34	Iwakiri, S.	Economic and Social Aspects of the Resources
35	Kuronuma, K.	Partial bibliography on biology and culture of penaeidean shrimps and prawns in Asia
36	Nishioka, Y. & Yamazaki, T.	An outline of major fishery in Thailand and a plan for the SEAFDEC area

Reference Papers

SEAFDEC/SCS.73:Ref-1	Shindo, S.	General review of the trawl fishery and the demersal fish stocks of the South China Sea
2	Kvaran, E.R.	Marine Fisheries potential in the Philippines and Southeast Asia
3	Iwakiri, S.	A note on fisheries exploration policy in Southeast Asia
4	Iwakiri, S.	Draft report on the fish marketing survey in Riau Archipelago
5	Suda, A.	Development of fisheries for non-conventional species
6	Marr, J.C.	Management and development of fisheries in the Indian Ocean
7	Tiews, K.	Fishery development and management in Thailand
8	Zachman, N.	Fisheries development and management in Indonesia
9	Payne, R.L.	Planning criteria for large-scale fisheries development with special reference to the Indian Ocean
10	Macalincag, N.G.	An economic analysis of Aquaculture in the Philippines
11	Gonzales, F.R.	Comparative economic analysis of brackish water fishpond and purse seine fishing
12	Macalincag, N.G.	Oyster farming: An economic appraisal
13	Pillay, T.V.R.	The role of Aquaculture in fishery development and management
14	Gulland, J.A.	Some notes on the demersal resources of Southeast Asia
15	Voss, G.L.	Cephalopod Resources of the world
16	Felix, S.S.	Bangos culture in fish pen in Laguna De Bay
17	Department of Fisheries, Thailand	Marine Fisheries Production in 1971 (Preliminary Report)