



## HANDBOOK ON

# COMMUNITY-BASED AQUACULTURE FOR REMOTE RURAL AREAS OF SOUTHEAST ASIA





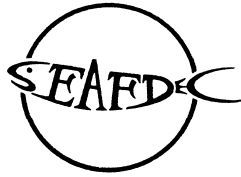

**HANDBOOK ON**

**COMMUNITY-BASED AQUACULTURE**

**FOR REMOTE RURAL AREAS OF SOUTHEAST ASIA**



**SOUTHEAST ASIAN FISHERIES DEVELOPMENT CENTER**

**SEC/SP/90**

**May 2008**

## **PREPARATION AND DISTRIBUTION OF THIS DOCUMENT**

This Handbook on Community-Based Aquaculture for Remote Rural Areas of Southeast Asia was prepared by the Secretariat of the Southeast Asian Fisheries Development Center (SEAFDEC) in collaboration with the Member Countries of the Association of Southeast Asian Nations (ASEAN), from the outcomes of the Joint Regional Training on Community-Based Aquaculture for Remote Rural Areas of Southeast Asia, which was jointly organized by SEAFDEC, the Department of Fisheries Thailand, the Department of Livestock and Fisheries of Lao PDR, the Mekong River Commission (MRC), the Asian Institute of Technology (AIT), and the World Wildlife Fund for Nature (WWF), from 1-15 July 2007 in Lao PDR with support from the Japanese Trust Fund. The Handbook is distributed to the ASEAN-SEAFDEC Member Countries, SEAFDEC Departments and concerned institutions.

## **BIBLIOGRAPHIC CITATION**

SEAFDEC. 2007. Handbook for Regional Training on Community-Based Aquaculture for Remote Rural Areas of Southeast Asia, Southeast Asian Fisheries Development Center, Bangkok, Thailand. 179 pp.

### **NOTICE OF COPYRIGHT**

This publication may not be reproduced, in whole or in part, by any method or process, without written permission from the copyright holder. Applications for such permission with a statement of the purpose and extent of the reproduction desired should be made through and addressed to:

SEAFDEC Secretariat  
Suraswadi Building  
Kasetsart University Campus  
P.O. Box 1046 Kasetsart Post Office  
Bangkok 10903, Thailand.

ISBN: 978-974-13-8735-9

All rights reserved

©SEAFDEC 2008

## CONTENTS

	Page
<b>Chapter 1 – Joint Regional Training on Community-Based Aquaculture for Remote Rural Areas of Southeast Asia</b>	1
<b>Chapter 2 – Community-based Aquaculture for Poverty Alleviation and Sustainable Livelihood</b>	5
<b>Chapter 3 – Freshwater Aquaculture Techniques for Rural Development</b>	
• Principles of Fish Farm Establishment	15
• Water Management	26
• Natural Food and Fish Feeds	42
• Principles of Fish Seed Production	59
• Aquaculture System	76
• Principles of Fish Health Management	104
• Harvest and Post-harvest Techniques	113
<b>Chapter 4 – Aquaculture-based Rural Livelihood Program Planning</b>	
• Community-based Aquaculture and Resource Management: Concepts and Approaches	121
• Understanding Community-based Aquaculture through Participatory Approaches	131
• Technology Transfer of Aquaculture Technologies: Framework and Strategies	140
• Business Planning and Management for Sustainable Small- Scale Rural Aquaculture Venture	150
<b>Chapter 5 – Suggested Reading</b>	
• Community-based Aquaculture in India- Strengths, Weaknesses, Opportunities and Threats	175

## PREFACE

The role of freshwater aquaculture in providing means of livelihood and ensuring sustainable food supply to the people particularly in the remote rural areas of Southeast Asia has become very apparent in the situation where fishery resources from the wild are over-exploited and affected by multiple water resource use and pollution. While recognizing the need to balance socio-economic and environmental dimensions in the development of freshwater aquaculture, SEAFDEC initiated a project on the “Promotion of Sustainable Freshwater Aquaculture for Rural Communities” under the Trust Fund Program of the Government of Japan with Lao PDR as the main participating and beneficiary country. As a main activity under the project, a two-week Joint Regional Training on Community-based Aquaculture for Remote Rural Areas of Southeast Asia was conducted in Lao PDR from 1 to 15 July 2007 in collaboration with the Department of Livestock and Fisheries of Lao PDR, Department of Fisheries of Thailand, the Mekong River Commission-Fisheries Programme, the World Wide Fund for Nature in Lao PDR, and the Asian Institute of Technology. Adopting a Training-of-Trainers approach, the training aimed to promote rural aquaculture in support of rural development for poverty alleviation and sustainable livelihood.

The Joint Regional Training comprised lectures, practical sessions, demonstrations, study visits, and discussions mobilizing the knowledge and experiences of the resource persons as well as those of the training participants. The topics covered during the training included community-based aquaculture for poverty alleviation and sustainable livelihoods; freshwater aquaculture techniques for rural development; and aquaculture-based rural livelihood opportunities.

As a major outcome of the Joint Regional Training, this Handbook on Community-based Aquaculture for Remote Rural Areas of Southeast Asia was developed considering the expertise of the partner and collaborating organizations as well as the experiences of the training participants. Additional information on community-based aquaculture based on the experience of India is also included in the Handbook to broaden the knowledge of the fish farmers on the topic. As this Handbook will be distributed to the ASEAN member countries, we envisaged that it would be translated into the national languages of the respective countries in order to better serve the region’s rural communities and to promote wider adoption of freshwater aquaculture technologies by the rural poor farmers for their sustainable livelihoods.

On behalf therefore of the partner and collaborating organizations of the Joint Regional Training, I wish to express our utmost gratitude to the participants and resource persons during the Joint Regional Training for sharing their expertise and experiences that have been well captured during the training and reflected in this Handbook. Our special gratitude also goes to the Department of Livestock and Fisheries of Lao PDR for the arrangements of the training and for providing the training venues. On behalf of SEAFDEC, I also wish to thank the Government of Japan for its continued support through the Trust Fund Program, specifically for financially supporting the project including the conduct of the Joint Regional Training as well as the publication and dissemination of this Handbook.



**Siri Ekmaharaj**  
Secretary-General  
SEAFDEC

## **CHAPTER 1**

### **JOINT REGIONAL TRAINING ON COMMUNITY-BASED AQUACULTURE FOR REMOTE RURAL AREAS OF SOUTHEAST ASIA**

Freshwater aquaculture has been practiced in Southeast Asia for centuries providing livelihood to rural people and ensuring sustainable supply of fishery products to the local populace and food security. Considering that the rural poor people generally lack access to technology, information, capital and inputs for livelihoods, community-based aquaculture has been identified as an approach to look into their collective needs and aspirations using aquaculture as a source of food and livelihood to alleviate their socio-economic conditions.

To assist the countries in Southeast Asia in developing their rural freshwater aquaculture, a project on the “Promotion of Sustainable Freshwater Aquaculture for Rural Communities” has been initiated by SEAFDEC with funding support from the Japanese Trust Fund. The project, which aims to promote appropriate aquaculture systems that could be applied in remote rural areas in Southeast Asia where most people have long been ignored due to their isolation from the most basic infrastructures, is being implemented in collaboration with the Department of Livestock and Fisheries (DLF) of Lao PDR. The project focuses on capacity building activities by promoting exchange of experiences, developing the capabilities of the countries’ key extension staff, mobilizing expertise in the region, and sharing of experiences on rural freshwater aquaculture.

Recognizing that appropriate technologies for freshwater aquaculture are already available in the region, the project is envisaged to ensure that such technologies could be readily adapted in the local context of each country. As such, an important component of the project’s capacity building component is the compilation of existing regional competence and experiences in matters of interest and thereafter, promoting the sharing of such experiences among the countries in the region for adoption and/or verification based on their respective conditions and requirements.

Thus, a Regional Training on “Community-based Aquaculture for Remote Rural Areas of Southeast Asia” was identified as a major activity under the project after a series of consultations among parties concerned particularly during the Preparatory Meeting on Promotion of Community-based Fish Farming in Remote Rural Areas of Southeast Asia from 16 to 17 January 2007 at Huayson-Huaysua Agricultural Development Center, Vientiane, Lao PDR. The concept and direction for the joint regional training are based on the review of the regional needs as well as development context and requirements, taking into consideration the identified common constraints and needs.

Intended for relevant government officers (e.g., extension officers) from the region, the first session of the Joint Regional Training was conducted from 1 to 15 July 2007 in Lao PDR in collaboration with the Department of Livestock and Fisheries (DLF) of Lao PDR, the Department of Fisheries (DOF) of Thailand, Mekong River Commission Fisheries Programme (MRC-FP), Aquaculture Outreach Programme (AOP) of the Asian Institute of Technology (AIT), and the World Wide Fund for Nature (WWF) in Lao PDR. The training in July 2007, which mainly aimed to produce a training package that will be disseminated in the region as an output of the project, was participated in by 23 representatives from the ASEAN countries. The resource persons and lecturers who supported the training were from the DOF of Thailand, MRC-FP, AIT-AOP, DLF, Living Aquatic Resources Research Center (LARReC), and from SEAFDEC Aquaculture Department.



## OBJECTIVES

The Joint Regional Training aims to acquire and apply.

- Knowledge in working with communities through participatory approach;
- Additional knowledge on freshwater aquaculture systems;
- Skills in the transfer of freshwater aquaculture technologies in rural areas; and
- Skills in extension services.

## OUTPUTS

The expected outputs from the training sessions include:

### **Enhanced Capacity Building of Aquaculture Extension Officers:**

More than 30 aquaculture officers will be able to obtain knowledge on community-related development skills and aquaculture technologies as well as extension service skills. The training is envisioned to enable them to carry-out works on technology transfer of freshwater aquaculture systems for the rural poor farmers through community-based approach.

### **Training Package:**

Based on the training materials prepared and compiled, a training package will be developed in collaboration with the partner organizations and resource persons/trainers. The training package will be verified through the training activities before circulating this in the region for their use and for awareness building. Translation of the training package into the different languages in the region will be encouraged for their respective national and local training activities.

## TRAINING DESCRIPTION

The Joint Regional Training is conducted as Training-of-Trainers (TOT) for aquaculture extension officers in support of rural development for poverty alleviation and sustainable livelihood. The training covers the topics on community-based fisheries management; aquaculture for poverty alleviation and sustainable livelihood; aquaculture-based rural livelihood program planning; fisheries extension and participatory technology transfer; and freshwater aquaculture techniques (e.g., integrated freshwater aquaculture) for rural development focusing on indigenous fish species.

Conducted in English, the training comprises lectures, practical sessions, workshops, demonstration, and study and site visits, while exchange of experiences and techniques among participants would be encouraged. Through partnership arrangements with the Department of Fisheries of Thailand as well as the other partner organizations, i.e. MRC, AIT-AOP, and WWF-Lao PDR, mobilization of expertise and resources persons for the training would be enhanced.

## PARTICIPANTS

The target participants should have and should meet the following qualifications:

- Nominated by SEAFDEC Council Directors as the policy makers of the national fisheries authority of respective countries;
- Good command of spoken and written English;
- Not more than 45 years old with educational background in fisheries/aquaculture and with at least two years experience in rural freshwater aquaculture;
- Responsible for the development/implementation of extension work or technology transfer of freshwater aquaculture;
- Must be in good health condition, both physically and mentally; and
- Women, who will be encouraged to participate in the training.



### **Requirements from the Participants:**

The selected participants from each country should submit a report on their working experiences related to the training, specifying successes or failures to be used as a basis for discussion during the training activities.

### **TRAINING OUTLINE**

For its first session, the 15-day joint regional training was conducted from 1 to 15 July 2007 at Huayson-Huaysua Agricultural Development and Service Centre, Vientiane, and Pak-bo Fisheries Station, Savannakhet Province, Lao PDR. The training comprised these following subjects/activities:

2 July 2007	Training Orientation (0.25 days)
2 July 2007	Work Status Reports (0.75 days)
3 July 2007	Community-based Aquaculture for Poverty Alleviation and Sustainable Livelihoods (0.5 days)
3-6 July 2007	Freshwater Aquaculture Techniques for Rural Development (4 days)
8-9 July 2007	Aquaculture-based Rural Livelihood Program Planning (2 days)
10-13 July 2007	Field Practical Sessions, Study and Site Visits (3.5 days)
13 July 2007	Training Conclusion and Evaluation (0.5 day)

### **RESOURCE PERSONS AND TRAINING STAFF**

#### **The Resource Persons for the first session were:**

1. Mr. Bunchong Chumnongsittathum (BC), Department of Fisheries, Thailand
2. Mr. Choltisak Chawpaknum (CC), Department of Fisheries, Thailand
3. Mr. Arkom Choomthi (AC), Department of Fisheries, Thailand
4. Mr. Renato F. Agbayani (RA), SEAFDEC Aquaculture Department
5. Dr. Suchart Ingthamjitr (SI), MRC-Fisheries Programme
6. Mr. Kaviphone Phouthavongs (KP), MRC-Fisheries Programme
7. Mr. Lieng Kamsivilai, Living Aquatic Resources Research Center (LARReC)

#### **The first session also had the following Training Staff:**

1. Ms. Pouchamarn Wongsanga (PW), SEAFDEC Secretariat
2. Mr. Suriyan Vichitlekarn (SV), SEAFDEC Secretariat
3. Mr. Chanthaboun Sirimanotham (CS), Department of Livestock and Fisheries (DLF), Lao PDR
4. Mr. Phantavong Vongsamphan (PV), DLF, Lao PDR
5. Mr. Bounthien Somhaboun Provincial Agriculture and Forestry Service Office (PAFSO)
6. Mr. Kamchan Sidavong Provincial Agriculture and Forestry Service Office (PAFSO)
7. Mr. Bounthong Sengrilaykham, AIT Field Coordinator, Lao PDR



## CHAPTER 2

### COMMUNITY-BASED AQUACULTURE FOR POVERTY ALLEVIATION AND SUSTAINABLE LIVELIHOOD

#### SUBJECT PLAN

<b>Subject</b>	Community-based Aquaculture for Poverty Alleviation and Sustainable Livelihood
<b>Date/Time</b>	3 July 2007, 09.00-10.30 hrs
<b>Officer-in-charge</b>	Mr. Bunchong Chumnongsittathum
<b>Objectives</b>	After the subject, The participants will be able to: <ol style="list-style-type: none"> <li>1. Understand the concept of community-based aquaculture in the rural area.</li> <li>2. Explore required information for extension works.</li> <li>3. Apply the related information and tools to succeed the project aims.</li> </ol>
<b>Topics</b>	<ol style="list-style-type: none"> <li>1. Principles of Community-based Aquaculture.</li> <li>2. Resource potential for Community-based Aquaculture.</li> <li>3. Methodology</li> <li>4. Problem identification for technology implementation</li> <li>5. Impact assessment</li> <li>6. Conclusion</li> <li>7. Self sufficient</li> <li>8. New Theory</li> </ol>
<b>Detailed Activity</b>	
<b>Time</b>	<b>Sub-activity</b>
<b>3 July 2007</b>	
<b>09.00-10.30</b>	<b>Community-based aquaculture</b> State briefly on the purposes of the program including short related topics on how to carry and hold on the project for success and sustainable livelihoods including with the sufficient economy and new theory.



## **COMMUNITY-BASED AQUACULTURE FOR POVERTY ALLEVIATION AND SUSTAINABLE LIVELIHOODS**

*Bunchong Chumnongsittathum,  
Tak Inland Fisheries and Development Center, Thailand*

Fish is a staple food for people in many parts of the world, particularly in Asia. It is an increasingly important source of protein, not only for food security but also as it is a fast renewable resource. Asia is the home of aquaculture, a practice which dates back to thousands of years. In the course of its development, the nature of aquaculture has become more intricate, intertwining with other food production sectors under the influence of political, social, economic, technological and cultural factors. With advancement of technology, the involvement of more aquatic species and farming practices has become possible, and more choices can be offered to the consumers. Population growth, economic growth and the development of disposable income and higher purchasing power, and social factors such as traditional fish consumption patterns, will shape future demand for fish and fishery products (Westlund, 1995). Issues of sustainability can also change our perception of desirable forms of aquaculture development and management (Roberts and Muir 1995). Under the evolving global trade negotiations and agreements, new ways of aquaculture may have to be adopted, so that the environmental and resource costs of production, as factors of sustainability, are kept within agreed limits. It could become increasingly difficult to pursue the traditional methods of aquaculture where a particular species is produced for a market, based exclusively on prices. Under the World Trade Organization, suppliers would have to satisfy a set of requirements to ensure sustainable development of aquaculture.

The sectoral review reveals the rapid rise of commercial aquaculture production, although the fast increase in the value of fish was attributed to a growing propensity towards high-valued commodities. Aquaculture exports have earned handsome amounts of foreign exchange for the producing countries, often at the expense of environmental degradation and loss of lives and property due to subsequent natural disasters and to resource-use conflicts. Aquaculture has been at the forefront in terms of natural resource-use conflicts, open access and weak political system, poor legislation and law enforcement. The sustainability of commercial aquaculture continues to remain in doubt as long as water pollution, environmental degradation and excessive use of finite natural resources are to be blamed on aquaculture.

As an optional food production activity, aquaculture involves various users, systems, practices and species. National planners assign a high priority in nation building to aquaculture, particularly when capture fishery is approaching its upper productive limit. Among all food production sectors, aquaculture has raised the hopes of national planners as a means to address the serious problems of hunger, poverty and unemployment.

Commercial aquaculture has little to do with food security, since it supplies food to the affluent sectors of society. Small-scale aquaculture practiced in harmony with the existing farming system makes quality daily meals more affordable for rural folk deprived by scanty infrastructure and by poverty. The synergy with other farming practices which small-scale aquaculture brings to deprived farming families translates into not only greater volumes of production but also a more balanced composition of the diet. It should become an important means to increase awareness of the value of land and water resources, for which heavy competition is in the offing.

The development of commercial aquaculture brings with it a totally different scenario and a different set of technical and socio-economic problems. The competition over common finite natural resources which commercial aquaculture will have to encounter in the future makes its development policy different from that of small-scale aquaculture. Technology will be required to maximize profits and sustainability: production of high-value commodities, measures to enhance

food safety as required by international standards, efficient use of farm inputs, biotechnology, etc. Commercial aquaculture must fend off the broadsides of environmental and consumer activists over production and trade issues.

As aquaculture continues to domesticate new aquatic organisms, the role of national research institutes must be promoted. The research areas in brood stock management, seed propagation, feed and feeding, diseases, farm management, etc, offer wide opportunities for almost any institution to participate. The promotion of aquaculture of indigenous species should be supported. Cooperation between the aquaculture industry and national research institutes needs to be strengthened, not only for the effectiveness of their endeavours but also for the safety of the consumers and the harmony of all socio-economic activities dependent on the common natural resource base.

## **COMMUNITY-BASED AQUACULTURE**

Thai DOF has been responsible for rural fisheries development since 1982 under the Fifth National Economic and Social Development Plan (1982–1986). Many important projects, such as the Village Fish Pond Development Project (VFPDP) and several projects under royal initiatives have been carried out. The VFPDP is a state-sponsored initiative in support of community fishpond development projects, which has continued to date. Its objectives are to increase fish production for local consumption to generate local employment and to reduce malnutrition and poverty. Under the VFPDP, the mandate of DOF is to (i) support the rehabilitation or construction of village fishponds (reservoirs, swamps, and tanks); (ii) train local support personnel; (iii) increase the supply of fish seed or fingerlings; and (iv) provide technical advisory services. The rationale of VFPDP stems from aims to strengthen social cohesiveness and develop community awareness, and the fishponds generally serve as core facilities that provide self-help opportunities. Apart from generating direct benefits in terms of fish production and improved water supply, the VFPDP trains villagers to be self-reliant. The dissemination of fish farming technology has resulted in the establishment of many fishponds by private individuals and communal fishponds in villages. In 2001, the Government decentralized authority for management of natural resources, including fisheries in all community waters, to the subdistrict governments, locally known as Tambon Administrative Organizations (TAOs). TAOs have become local institutions responsible for rural development. In the context of these decentralization measures, the DOF's budget for village pond construction was being progressively transferred to TAOs during 2001–2004.

Water for small-scale rural aquaculture is generally available, especially in floodplain and irrigated areas. However, the water supply for aquaculture is restricted in drought-prone areas in the northeast where there is significant poverty, and in ponds inappropriately located in hilly areas. In areas where agricultural chemicals are used intensively, water is contaminated with pesticides at low concentration. Measurements in 25 river basins, including Bangpakong, Chaopraya, Kok, Pasak, Sakakrang, Songkhla Lake, Tha Chin, and Yom, showed them to have poor average water quality in terms of dissolved oxygen (DO), biochemical oxygen demand, coliform bacteria, and ammonia-nitrogen. The average DO levels in the lower Tha Chin River were reported to be as low as 1 milligram per liter, unsuitable for fish and aquatic organism. Water quality in the main rivers in the north (Nan, Ping, Wang, and Yom) remains generally good, especially in the upstream flow from the northern mountains, and the average concentration of DO was more than 5 milligrams per liter. Nonpoint source pollution became significant in many parts of the country during the late 1990s, especially in water from agriculture areas.

In some areas, especially in the northeast, saltwater intrusion has a strong effect on freshwater aquaculture. Water temperature is also important for rural aquaculture. In the winter in the north, temperatures may drop to less than 10 degrees Celsius and cause detrimental effects on fish culture. In newly constructed ponds, water turbidity is common.



The Government has promoted aquaculture for decades, through both research and extension services. The government strategy for promoting small-scale rural aquaculture in the past included the provision of subsidized inputs. The Government has provided substantial support and incentives to farmers by providing free advisory services for the promotion of aquaculture technologies, and subsidized inputs for pond construction, seed, feed, and lime to fish farmers. The Government has, however, realized that subsidies do not necessarily lead to sustainable aquaculture development, and that it is necessary to extend adequate and appropriate information on aquaculture technologies to targeted fish farmers effectively.

DOF has played an important facilitating role in rural aquaculture development, planning, and implementation. Its services include aquaculture extension and transfer of fish farming technologies to farmers. While fisheries organizations or cooperatives may be found in areas where there are considerable aquaculture activities, the roles of these farmers' organizations are primarily related to marketing, an area of common interest among farmers. DOF has not been able to mobilize the support of these organizations to deliver its extension programs because of various shortcomings affecting the farmers' organizations and the aquaculture extension services. Privately managed cooperatives in freshwater aquaculture have generally faced financial and human resource constraints. However, community participation in aquaculture development through village committees, district councils, or subdistrict TAOs has been evident. In this context, fish farmers and villagers participate in planning and making decisions on their community resource use and conservation.

The Government is attempting to make the extension system more responsive to farmers' actual needs, particularly by providing information more appropriate to farmers' conditions. In October 2002, it reorganized the overall agricultural extension system and the central responsibilities of DOF in terms of technology development and extension. These are now limited to training functions and providing assistance in the preparation of extension materials in the newly established Bureau of Fishery Technology Transfer and Extension.

Under the new extension system, the Department of Agricultural Extension has been mandated to be the sole government agency to organize training as well as farmer selection in all agricultural disciplines, including fish farming. Under the new arrangements, all training activities are decentralized and conducted through the Tambon Technological Transfer Center, which is meant to be a one-stop service center where farmers and local residents can get advice and information, and contact experts in various disciplines.

## **COMMUNITY-BASED RURAL AQUACULTURE DEVELOPMENT**

Community-based aquaculture in Thailand has contributed to the development of selfhelp initiatives, local ownership, and decision making in the communities. DOF has promoted small-scale and community-based freshwater aquaculture for many years, including through the VFPDP, and there have been both successes and failures. The main factors that have influenced the success of community-based aquaculture are (i) the demand for and the extent of interest in fish farming; (ii) social capital, including organizational arrangements that contribute to strong community participation, sharing access to resources, and conflict resolution; and (iii) government assistance and partnerships with the communities. Drawing from experience, constraints to rural aquaculture include water shortages, unfavorable biophysical conditions, low natural productivity, and such farm management issues as stocking density, pond management, access to feed, and harvesting methods. Fish farming has also been affected by environmental degradation, limited financial and human resources, inappropriate links between extension and research, and external shocks such as the effects of the Asian financial crisis of 1997.

One of the most promising government support programs for poor communities to increase rural fish production is the School Fishpond Program (the Lunch Program) under Her Royal Highness Princess Maha Chakri Sirindhorn. The target areas are village schools, mainly primary and, to a

lesser extent, secondary schools, in remote areas. The main objective of this program is to improve the nutritional status of school children in these areas by providing fish for consumption through self-help initiatives in fish farming. The program, which began in 1992, includes construction of fishponds, aquaculture training, and provision of fish seed and technical advice to schools. The Lunch Program has also piloted an integrated fish-poultry farming project to increase fish production at low cost. Despite encouraging outcomes, constraints affecting the program include limited water supply, inadequate feed and other inputs, and limited knowledge in fish farming. There is scope for improvement and expansion to take advantage of the village schools as institutions that act as a focal point in remote areas at the grassroots level. There are opportunities for adaptive and hands-on learning in fishpond management and other aquaculture related issues. Through a series of simple activities involving village fishponds or small waterbodies, students and the communities can participate in an experiential learning process that actively demonstrates the potential benefits of improved fishpond management to livelihoods and human nutrition.

**Table 3:** Pilot Integrated Fish and Poultry Farming Project Production Statistics under the School Lunch Program in 2000

Region	Number of Schools	Chickens Layer	Number of Eggs Produced	Fish Production (kg)	Total Income (B'000)
Northeastern	4	1,250	351,852	405	598
Northern	4	900	246,145	421	459
Central	3	550	147,119	308	231
Southern	1	504	129,936	365	235
<b>Total</b>	<b>12</b>	<b>3,204</b>	<b>875,052</b>	<b>1,499</b>	<b>1,523</b>

Source: Department of Fisheries. 2002. Smallholder Aquaculture Research and Development. Bangkok, Thailand

## DEVELOPMENT POLICY FOR SMALL-SCALE FRESHWATER AQUACULTURE

National development by the Government takes place through the National Economic and Social Development Plan (NESDP). The principal strategic objective of the NESDP is to promote economic development by utilizing natural and human resources to increase production, generate employment, and increase national incomes. The direction of rural aquaculture development has developed from the fifth to the eighth NESDPs. The relevant stated goals were to (i) alleviate malnutrition (NESDP 5, 1982–1986); (ii) accelerate fish culture activities (NESDP 6, 1987–1991); (iii) increase opportunity for establishment of individual fishponds (NESDP 7, 1992–1996); and (iv) increase human resource capacity in managing integrated community fishponds (NESDP 8, 1997–2001).

Thailand's National Fisheries Policy on aquaculture aims to (i) increase fish production to meet the demand for domestic consumption; (ii) increase income for fish farmers; and (iii) raise the standard of living of small-scale fish farming households, as well as to increase fish production as export products from coastal aquaculture. Current strategies focus on (i) developing and improving aquaculture techniques by conducting research to increase fish production and to reduce production costs; (ii) conducting research on fish species with high economic potential to improve their desirable characteristics, and to develop good practices for hatcheries and aquaculture farms; and (iii) providing technical services and certifying registered hatcheries and farms.

The National Fisheries Policy hinges on the assumption that future rural aquaculture development will remain at a small-scale and subsistence level, mainly for domestic consumption and local household food security, especially for the rural poor. This limits the scope for intensifying the systems. The major role of researchers, therefore, is to find innovative and viable low-cost, low-



input technology options for such conditions. Appropriate technology options for small-scale freshwater aquaculture have been developed in Northeastern Thailand.

The Government decentralized authority for management of fishery resources in all community waters to TAOs in 2001. TAOs had previously facilitated aquaculture development in their jurisdictions by requesting government support for fishpond construction, with DOF providing technical assistance. Achievements of these fishpond development initiatives have been variable. **Principal shortcomings were inadequate fishpond management, ineffective extension services, deficient co-management mechanisms and practices for common and shared assets, and poor access at the village level to information on aquaculture.** The TAOs still have limited experience in natural resources management and need to develop their credibility and establish the trust of the communities. In the past, the communities did not have the opportunity and experience to make appropriate and enforceable resource management decisions. The TAOs can, and increasingly must, play a role in arbitrating and facilitating the management of community natural resources. There are opportunities for capacity building and for forging close partnerships between the stakeholders in the communities and government services, including fisheries officers and TAO officials, through a participatory learning process and iterative improvements.

Currently, the Fisheries Act (1947) prohibits private pond construction in the public domain. However, fish farmers have rights to construct fishponds on their own land (property). Fish farmers can also operate cage culture in public waters. Such fish cage farms have to fulfill certain requirements for obtaining government permission, such as non-obstruction of waterways or transportation, non-disturbance to the public, a suitable location, and approval by district and provincial authorities. Licenses for fish cage farming are normally granted for 5 years. At present, sub-district governments, Royal Irrigation Department, Royal Forest Department, and the Electricity Generation of Thailand are also involved in authorizing cage culture in their areas of jurisdiction.

The Fisheries Act does not require freshwater aquaculture activities operating on private property to register and obtain permission. Nevertheless, the Government requires all aquaculture operators to register with the competent authority and get permission before operating. Fish farmers have traditional rights to access a water supply from rivers and reservoirs. Changes to the Water Law are being considered, with the possible introduction of charges for water, especially for recreational use, such as watering golf courses. Fish farmers have exclusive rights to produce. The Government has no policy to regulate fish producers, unless they farm restricted species, i.e., endangered species listed by laws. However, in the future, the Government will apply concepts and practices guided by the FAO Code of Conduct for Responsible Fisheries and associated guidelines. The code puts emphasis on environmental aspects (effluents and water discharge), drugs and chemicals used in aquaculture, improvement of quality of fish products, preservation of fish products after harvesting, and quality control of fish products.

## **SAFEGUARDS FOR FRESHWATER AQUACULTURE**

### **Aquaculture Zoning**

Aquaculture zoning can serve as a tool for planning and implementing aquaculture activities to mitigate adverse environmental impacts. For example, in the absence of zoning, the rapid expansion of marine shrimp farms into freshwater areas of several provinces in Central Thailand has generated conflicts in uses of land and water resources. Salinity intrusion was attributed to shrimp farming that affected freshwater ecosystems, ricefields, and orchards. This situation led to the enforcement, from December 1997, of Article 9 of the Environmental Act of 1996 to ban low-salinity shrimp farming in freshwater areas throughout the country.

### **Integrated Agriculture-Aquaculture.**

Integrated agriculture-aquaculture has been practiced for almost a century, initially in Bangkok but at present throughout the country. The most popular systems are fish/poultry culture, fish/pig



culture, and mixed culture (fish, pig, and poultry). DOF has conducted several programs to increase fish production through integrated farming. The Bank for Agriculture and Agricultural Cooperatives (BAAC), with support from the Belgian Administration for Development Cooperation (BADC), developed guidelines for integrated fish farming in Northeastern Thailand. Integrated livestock/fish farming systems safeguard the environment because the livestock manure is used as organic fertilizer for the fish ponds, which also function as waste stabilization ponds. A technology divide has developed over the past decade in which traditional semi-intensive aquaculture using on-farm and locally available agricultural residues is being replaced by relatively high-cost intensive culture using formulated pellet feed. However, a third system—a semi-intensive system based on inorganic fertilization and supplementary feeding—can effectively intensify fish production for small-scale farmers and reduce the cost of production for large-scale producers. This system is more environmental friendly than intensive production that relies solely on pellet feed.

### **Biosafety and Disease Prevention.**

Introductions and transfers of alien aquatic species have been made deliberately and accidentally. Alien species were introduced mainly for aquaculture and the aquarium trade and in many cases were imported illegally without adequate quarantine. Freshwater aquaculture is constantly exposed to the risk of possible adverse impacts from introductions of alien species and farmed organisms, particularly from the introduction of diseases and parasites. Enforceable and effective safeguards need to be developed, taking into account practical recommendations for biosafety measures. However, the implementation of aquaculture health management guidelines for transboundary movements of live aquatic animals (such as health certification, quarantine, and diagnostic procedures) farmers, researchers, and the general public, in order to minimize preventable and potentially damaging risks from irresponsible introductions and dissemination of alien aquatic species and farmed organisms.

### **Lessons Learned**

Fish farming has developed rapidly over the last few decades, partly in response to a decline in capture fisheries and to a rising demand for fish. Small-scale farmers have benefited from the development of aquaculture, although existing data do not allow measuring the socioeconomic benefits to these farmers. Fish are an important component of the Thai diet and contribute significantly to national food security and human nutrition. Fish provide a traditional source of animal protein, fatty acids, and micronutrients. Fish marketing in Thailand is competitive and largely in the hands of the private sector. With good road networks, transportation, supporting infrastructure, and telecommunications, fish and fish products flow freely in the country. This enables Central Thailand to supply fish to deficit areas such as Northeastern Thailand where retail prices of fish are generally higher than in other parts of Thailand. Northeastern Thailand is home to the majority of small-scale farmers in the country, and these small-scale producers have faced increasing pressure to improve farm productivity and reduce production costs to remain competitive in a free market system.

The rural poor comprise producers and consumers, and suppliers of labor. In the context of small-scale aquaculture, the rising opportunity cost of labor because of rapid economic development and employment opportunities in Thailand as well as overseas has placed additional pressure on farm productivity, which must rise if fish farming is to remain an attractive livelihood option. This economic environment places restrictions on the appropriateness of technology for small-scale aquaculture. Low-cost and affordable technology does not necessarily provide high returns on labor inputs, while intensive farming can create a demand for financial and other resources that the poor do not have. In many areas of Northeastern Thailand, labor migration to urban areas, particularly to Bangkok and its vicinity, has caused farm labor scarcity. These conditions restrict farm households from adopting labor-intensive farming techniques.

DOF has played a major role in the development of aquaculture in the country over the last few decades. DOF started to promote farming of native snakeskin gourami in the 1930s, but did not



succeed due to low demand for farmed fish at that time and an abundant supply of and high demand for wild fish. Mozambique tilapia was promoted in the 1950s, but its culture did not succeed because of unfavorable characteristics that constrained on-farm productivity, and the species did not meet consumers' tastes and preferences. However, promotion of Nile tilapia since the 1960s has been a success, and it is now among the major farmed fish species in Thailand. These development milestones have emphasized the importance of demand, market conditions, and the appropriateness of the product to meet the demand. Introduction and promotion of fish species for farming require an astute demand assessment and the ability to sustain a viable supply. Nile tilapia meets the demand of Thai consumers, as well as the needs of farmers to produce fish at reasonable cost to generate attractive returns.

DOF has placed great emphasis on the development of fisheries stations, which have catalyzed the development of the private sector's dominant role in seed production and seed supply to support the increasing importance of fish farming. While the Government has played an instrumental role in placing the necessary facilities for initiating and ensuring seed supply to promote fish farming, its role has not hindered the private sector from developing and taking over the seed supply business. Overall, the private sector provides a reliable supply of seed in Thailand, with complementary development initiatives in the feed industry. Without a reliable seed supply, fish farming would not have developed into a major industry. Seed supply has been a major constraint to the adoption of aquaculture in many countries. The Government has sustained its research and development initiatives on fish breeding to maintain good quality broodstock to ensure open public access to farmed species and strains of good performance. The roles of the private and public sectors in seed production and quality assurance are complementary.

## WAYS TO BENEFIT THE POOR

DOF also currently assists the rural poor through aquaculture extension services based on the distance extension approach, **using technologies appropriate for household-level and pond-based aquaculture**. Most local communities and individual farming households have limited resources at their disposal; thus, less technical but demand-led approaches are required to reach poor target groups. Nevertheless, challenges in developing viable technology options for aquaculture continue to emerge in the rapidly changing rural economy. In responding to challenges to make aquaculture benefit small-scale farmers, several factors should be considered: (i) livelihood options of targeted groups, including existing sources of household incomes; (ii) opportunity cost of labor, employment opportunities, and labor market characteristics, including labor migration; (iii) affordability and the extent to which targeted users of technology have access to livelihood assets for fish farming; and (iv) markets and marketing of farm inputs and outputs, and their specific relevance to fish farms. Responding to the challenges requires capacity building of local government agencies and local service providers. Adaptable approaches are needed without relying on rigidly predetermined packages of technology. Analyzing the characteristics of households or small-scale farmers and assessing the specific features of their operating environment are important elements in appraising ways to make aquaculture work for small-scale farmers.

Innovative approaches to enhance learning and community participation in the planning and use of water resources for integrated aquaculture-agriculture can improve livelihood options and enhance benefits for targeted groups. DOF could support such approaches by targeting agents of learning and information dissemination, such as teachers, students, community-based organizations, village leaders, and extension officers. Understanding relevant features of water resources management and their competing and complementary uses can prevent conflicts and mitigate adverse environmental impacts. Further, addressing issues related to common property rights and access to land and water resources may ease access gaps to critical livelihood assets for the poor to engage in small-scale aquaculture.

A promising way to alleviate malnutrition among poor children in remote rural areas is the School Fishpond Program mentioned earlier. While the program provides immediate direct nutritional benefits among students of targeted schools, the benefits go beyond the school boundaries; the program serves as a catalyst in the communities to promote the use of water resources for integrated aquaculture-agriculture. The schools act as a focal point, providing outreach to students, parents, and other members of the communities, and a hub for information exchange and dissemination.

### **Self-sufficient economy**

- Attitude on the sustainable livelihoods.
- Self-sufficient economy is given by His Majesty King Bhumibol Adulyadej of Thailand.
- farmers, merchants, businessmen, government officials or others.
- means having enough to live on and to live for
- Being self-sufficient means to have enough to live on and to live for, and to refrain from leading a luxurious and extravagant life, just having enough
- Self-sufficiency, in English, means that whatever we produce, we have enough for our own use. We do not have to borrow from other people. We can rely on ourselves, like what people say, we can stand on our own legs. It means having enough and being satisfied with the situation. If people are satisfied with their needs, they will be less greedy. With less greed, they will cause less trouble to other people. Everything must be within its limits. Saying what is necessary, acting just to have enough which means being satisfied at a moderate level,

### **New Theory**

- In 1992, His Majesty introduced the "New Theory"
- to be implemented at the Royally-initiated Wat Mongkol Chaipattana Area Development Project.
- to serve as a model of land and water management for the farmers.
- Theory; the land is divided into four parts with a ratio of 30:30:30:10.
- 30% is set aside for pond and fish culture,
- 30% for rice cultivation,
- 30% for growing fruit and perennial trees,
- 10% for housing, raising animals and other activities.

### **"New Theory" consists of the three following phases.**

- **Phase 1** : To live at a self-sufficient level which allows farmers to become self-reliant and maintain their living on a frugal basis.
- **Phase 2** : To cooperate as a group in order to handle the production, marketing, management, and educational welfare, as well as social development.
- **Phase 3** : To build up connections within various occupation groups and to expand businesses through cooperation with the private sector, NGOs and the government, in order to assist the farmers in the areas of investment, marketing, production, management and information management.



### CHAPTER 3

## FRESHWATER AQUACULTURE TECHNIQUES FOR RURAL DEVELOPMENT

### Principles of Fish Farm Establishment: Site Selection, Pond/Cage Design and Development

#### SUBJECT PLAN

<b>Subject</b>	Freshwater Aquaculture Techniques for Rural Development: Principles of Fish Farm Establishment -site selection, pond/cage design and development
<b>Date/Time</b>	3 July 2007, 10.45-12.30 hrs
<b>Officer-in-charge</b>	Mr. Arkom Choomthi
<b>Objectives</b>	After the subject, The participants will be able to: <ol style="list-style-type: none"> <li>1. Understand principles of site selection for fish farm establishment</li> <li>2. Understand principles of pond and cage design</li> <li>3. Apply appropriate principles of site selection, pond and cage design for extension works</li> </ol>
<b>Topics</b>	<ol style="list-style-type: none"> <li>1. Introduction of site selection for fish farm establishment</li> <li>2. Principles of site selection for fish farm establishment</li> <li>3. Pond and cage design and construction</li> </ol>
<b>Detailed Activity</b>	
<b>Time</b>	<b>Sub-activity</b>
<b>3 July 2007</b>	
<b>10.45-11.45</b>	1. Introduction and explain of principles of site selection for fish farm establishment
<b>11.45-12.30</b>	2. Explain of pond and cage design



## **PRINCIPLES OF FISH FARM ESTABLISHMENT: SITE SELECTION, POND/CAGE DESIGN AND DEVELOPMENT**

*Arkorn Choomthi  
Department of Fisheries, Thailand*

### **INTRODUCTION**

Fish farming is the principal form of aquaculture. It involves raising fish efficiently in ponds tanks, cages or enclosures, usually for food. A facility that releases juvenile fish into the wild for recreational fishing or to supplement for culture is generally referred to as a fish hatchery. Fish are excellent animals to rear. They can convert feed into body tissue more than most farm animals, transforming about 70 percent of their feed into flesh. Fish also have excellent dress-out qualities, providing an average of 60 percent body weight as marketable product and a greater proportion of edible, lean tissue than most livestock. Fish can be intensively cultured in relatively small amounts of water. They can be farmed at densities with careful management. Increasing demands on wild fisheries by commercial fishing operations have caused widespread overfishing. Fish farming offers an alternative solution to the increasing market demand for fish and fish protein.

Fish farming is, like most other types of farming that requires special knowledge, skills, and careful considerations. Individuals with little or no experience in fish farming and few resources available can become successful fish farmers, but they should start small and expand slowly, and be willing to invest lots of time and effort. Besides knowledge and skills, one of the most important factors to consider in determining whether you should begin a fish farming in location for fish farm establishment.

To be profitable, fish farm must be sited properly and designed for efficiency. An inaccessible location, leaks in the pond, lack of good quality water will doom an fish farm to failure. Ideally, fish farm built on flat land and used ground water or surface water are more suitable for fish production.

#### **Water availability**

Water for fish farm; ponds, hatcheries or tanks can come from a variety of sources; ground water (wells), surface water (springs, streams and reservoirs) which are available in the areas. The primary criterion is that adequate water of desirable quality be available.

#### **Water quality**

Selection of the water source has many considerations, including initial cost, permit restrictions and dependable quality. Water quality is one of the most factors to succeed fish farm especially, hatchery and cage culture. The water used should be good for fish growth and avoided contamination of wild fish, parasites and diseases that could result in fish loss and other costs.

#### **Soil type**

For fish production pond (earthen pond), good quality soil containing at least 20 percent clay is necessary for building dike and spillways. This includes clay, silty clay, clay loam and sandy clay. They must be held water and prevent water seepage. Pond construction, mainly concrete tanks in lime stone areas can be especially risky because underlying cracks and sinks. Soils should be checked for their texture.

#### **Soil texture**

Texture indicates the relative content of particles of various sizes, such as sand, silt and clay in the soil. Texture influences the ease with which soil can be worked, the amount of water and air it holds, and the rate at which water can enter and move through soil.

To find the texture of soil sample, first separate the fine earth, all particles less than 2 mm, from larger particles such as gravel and stones. Fine earth is a mixture of sand, silt and clay. You must be sure to use only fine earth to perform the following field tests.

*Grain size:*

Sand 0.05 – 2.0 mm, Silt 0.002 – 0.05 mm, Clay < 0.002 mm

Opening Sizes for USA Standard Wire Cloth Sieves Conforming to American Standard Testing Materials (ASTM) Specifications E 11.

USA Standard Series, ASTM No.	Opening Size (mm)	USA Standard Series, ASTM No.	Opening Size (mm)
5	4.75	80	0.18
10	2.00	100	0.15
20	0.85	140	0.106
30	0.60	200	0.075
40	0.42	270	0.053
50	0.30	400	0.038
60	0.25		

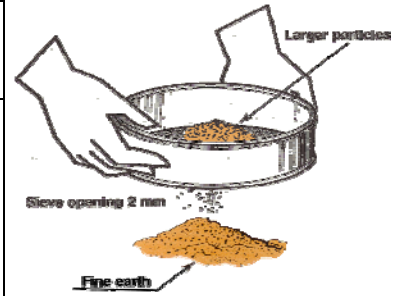

*Separation of soil particles.*

Triangular diagram of the basic soil textural classes according to USDA partical sizes

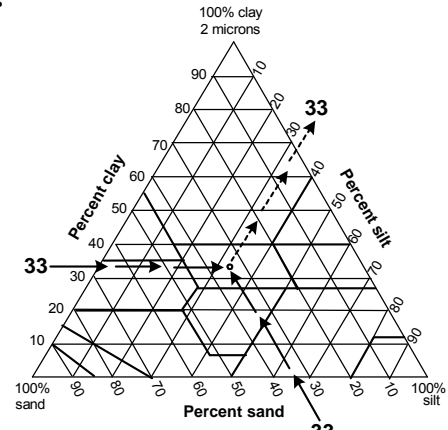
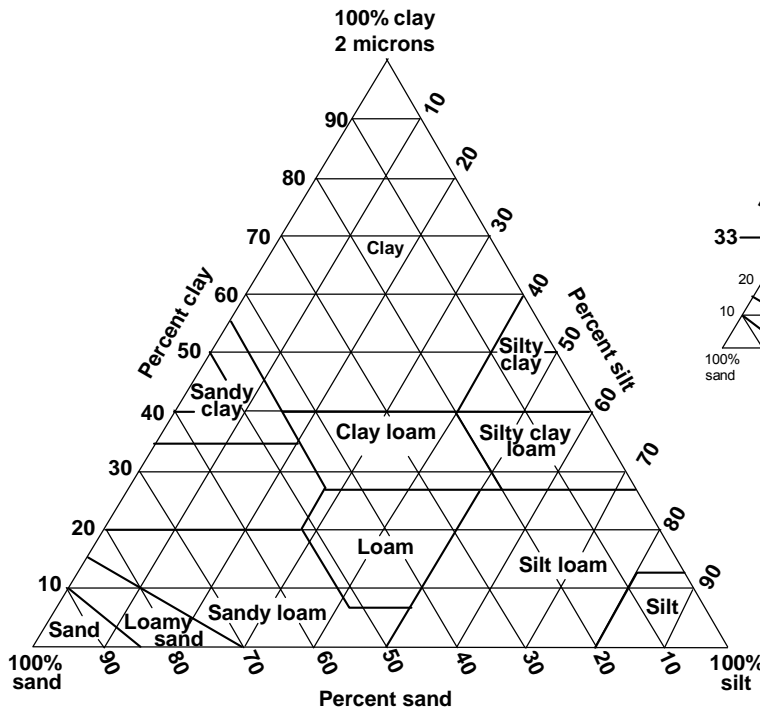

**PARTICAL SIZES (USDA)**

clay	<0.002mm
silt	0.002-0.05mm
sand	0.05 -2 mm

NOTE: The soil textural classes shown in the white portion of the large triangle are best for fish-pond construction.

*Triangular diagram of the basic soil textural classes according to USDA particle size*

USDA textural classes of soils: Soil texture (percentages, dry weight)

Common names of soils (General texture)	Sand	Silt	Clay	Textural class
Sandy soils (Coarse texture)	86-100 70- 86	0- 14 0- 30	0- 10 0- 15	Sand Loamy sand
Loamy soils (Moderately coarse texture)	50- 70	0- 50	0- 20	Sandy loam
Loamy soils (Medium texture)	23- 52 20- 50 0- 20	28- 50 74- 88 88-100	70- 27 0- 27 0- 12	Loam Silty loam Silt
Loamy soils (Moderately fine texture)	20- 45 45- 80 0- 20	15- 52 0- 28 40- 73	27- 40 20- 35 27- 40	Clay loam Sandy clay loam Silty clay loam
Clayey soils (Fine texture)	45- 65 0- 20 0- 45	0- 20 40- 60 0- 40	35- 55 40- 60 40-100	Sandy clay Silty clay Clay

The relative suitability as dike material of various types of soil.

Texture	Permeability	Compressibility	Compaction characteristics	Suitable as dike material
Clay	Impermeable	Medium	Fair to good	Excellent
Sandy clay	Impermeable	Low	Good	Good
Loam	Semi- impermeable to impermeable	High	Fair to very poor	Fair
Sandy loam	Semi- impermeable to impermeable	Medium to high	Good to very poor	Poor
Sand	Permeable	Negligible	Good	Poor
Peat				Very poor

A simple field test for estimating soil permeability

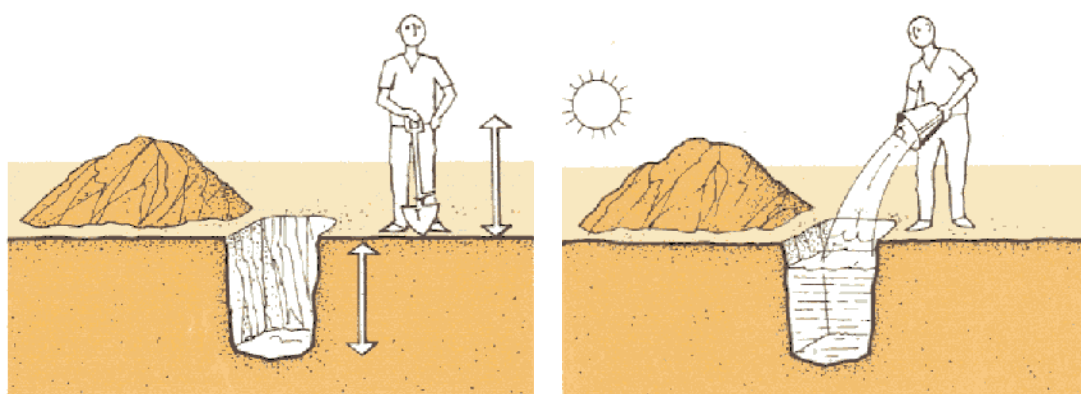

(1). Dig a hole as deep as your waist;

(2). Early in the morning, fill it with water to the top;



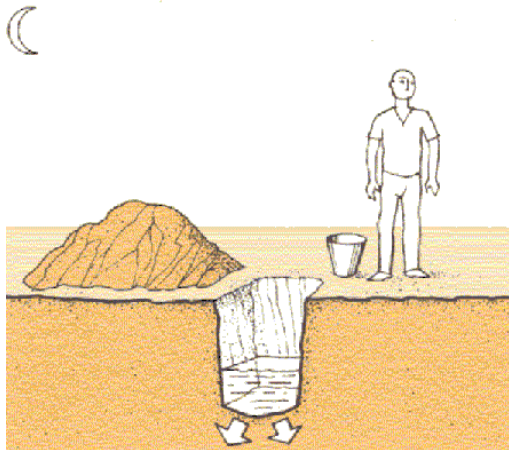

(3). By the evening, some of the water will have sunk into the soil;

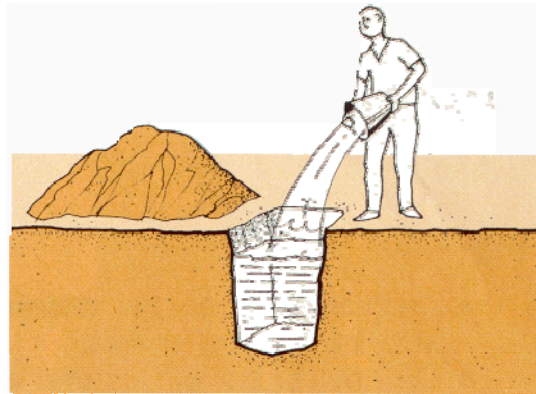

(4). Fill the hole with water to the top again, and cover it with boards or leafy branches;

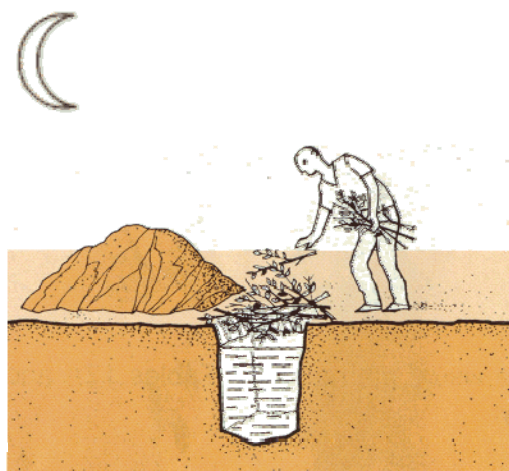

(5). If most of the water is still in the hole the next morning, the soil permeability is suitable to build a fish-pond here;

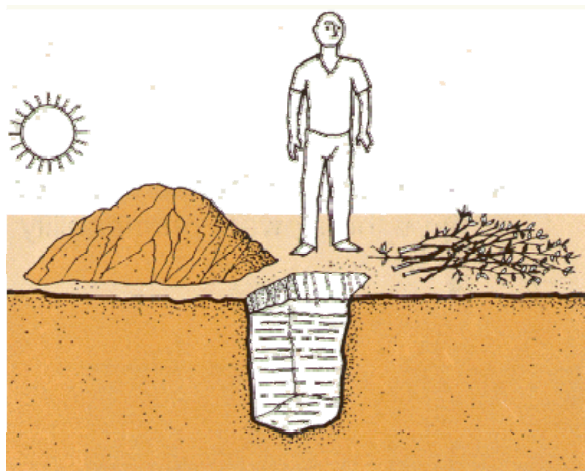

(6). Repeat this test in several other locations as many times as necessary, according to the soil quality.

### Quick field tests to determine soil texture

For fish-pond construction, it is better to have a soil with a high proportion of silt and/or clay which will hold water well. To check quickly on the texture of the soil at different depths, here are two very simple tests you can perform.

#### Throw-the-ball test

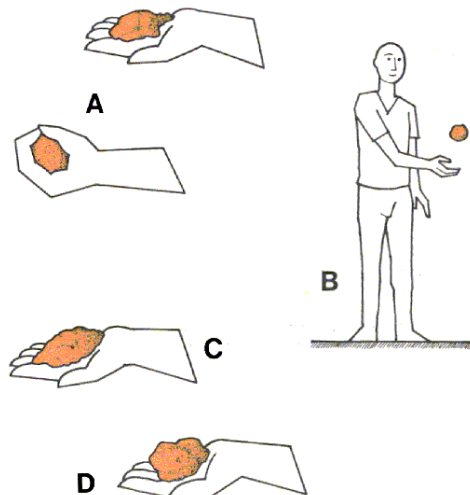

- Take a handful of moist soil and squeeze it into a ball (A)
- Throw the ball into the air (B) about 50 cm and then catch it...
- If the ball falls apart (C), it is poor soil with too much sand;
- If the ball sticks together (D), it is probably good soil with enough clay in it.

### How to find the approximate proportions of sand, silt and clay

This is a simply test which give you a general idea of the proportions of sand, silt and clay present in the soil.

#### The bottle test

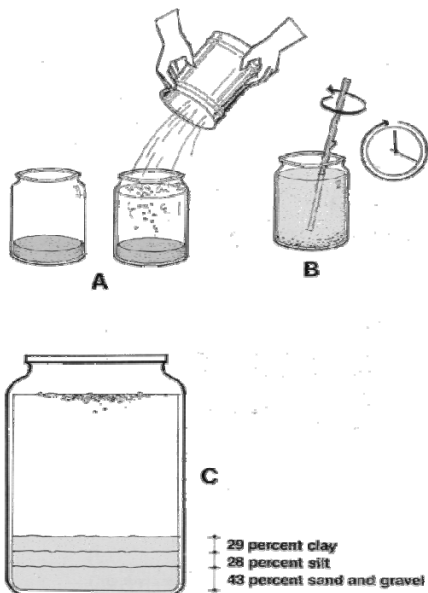

- Put 5 cm of soil in a bottle and fill it with water (A);
- Stir the water and soil well, put the bottle down, and do not touch it for an hour. At the end of an hour, the water will have cleared and you will see that the larger particles have settled (B);
- At the bottom is a layer of sand;
- In the middle is layer of silt;
- On the top is a layer of clay. If the water is still not clear, it is because some of the finest clay is still mixed with the water;
- On the surface of the water there may be bits of organic matter floating;
- Measure the depth of the sand, silt and clay and estimate the approximate proportion of each (C).

### Topography

Topography will determine the size and shape of fish farm components; hatchery or production ponds. Gently, flat land is better than sloping. However, some slope or drainage pattern is desirable for draining water from the ponds. Sites should be selected so that water outlet channels can be installed to drain the ponds completely. Floods from nearby water sources should not overflow the ponds.

### CRITICAL FACTORS FOR CAGE-SITE SELECTION

One of the most important factors to consider for cage-site selection is water quality. While many different sites are adapted to cage culture such as lakes, reservoirs, rivers and streams. To maximize good water quality, critical factors that should be considered are:

**Wind and water current.** It is important that the cage be in an area where it will receive maximum natural circulation of water through the cages. Usually, this is in an area that swept by the prevailing wind. However, the cages must be located apart from an area where risk to appear strong wind or storm.

**Water depth.** A minimum of 2 feet of water is needed under the cages to keep cages wastes away from the fish.

**Coves and weed beds.** Coves and weed beds and overhanging trees can reduce wind circulation and potentially cause problems.

**Disturbances.** Disturbances from people frequently walking on the dock, fishing or swimming near the cage, and/or from animals which frequent that area will excite the fish and can cause stress, injury, reduces feeding and secondary diseases.

## **OTHER SITE SPECIFIC CRITERIA**

After requirements for an area have been evaluated, more factors should be considered before final selection of a particular site. First consideration should be availability and second, the comparative cost for capital outlay and operations.

**Utilities.** The availability and cost of power are important factors in selection the site. Utility lines or pipelines rights of way across a potential site should be investigated.

**Accessibility.** This aspect must also be considered. Roads must accommodate vehicles that deliver feed and transport fish. If such roads are not present they must be built.

**Supplies and equipments.** Feed should be available at an economic cost. Ice may be necessary for used while harvesting and hauling fish. Equipments for pond construction and associated structures should be available.

**Labor.** Both skilled and unskilled labor are needed for all aquaculture installations. If not available locally, labor must be imported which may be a considerable cost.

**Market.** Market should be available and not so far from fish farm for transportation cost reason.

**Licenses and permits.** These vary between states and regions. Before making final site selection, contact state or government agencies for information on licenses, permits and regulations.

## **POND DESIGN AND LAYOUT**

This is important for efficient operation of any pond system. A good site survey and layout design will contain the following information:

1. Distances from water supply and access roads.
2. Location, top width, slopes, earth fill requirement, and elevation of dam
3. Emergency spillway location and size
4. Shoreline dimensions
5. Soils investigation report
6. Dimensions of the cutoff trench and core.
7. Location, dimensions and elevations of riser and barrel pipes
8. Estimate of the total cut and fill
9. Watershed area and characteristics
10. Materials needed

### **Pond size, depth and shape**

Size of production pond should be based on water supply. Water should be deep enough to compensate evaporation and seepage. Marketing strategy also influences pond size. Even during summer drought the water should be at least 1-1.2 meters. Generally, an average water depth in the production pond should be 1.2-1.5 meters. Pond shape should be based on areas, and compensated harvesting. Generally, the production pond is built in square or rectangular shapes of 800-1,600 squaremeters.

### **Pond morphometry**

- Size
- Length
- Width
- Surface area
- Depth

- Dike slope
- Volume

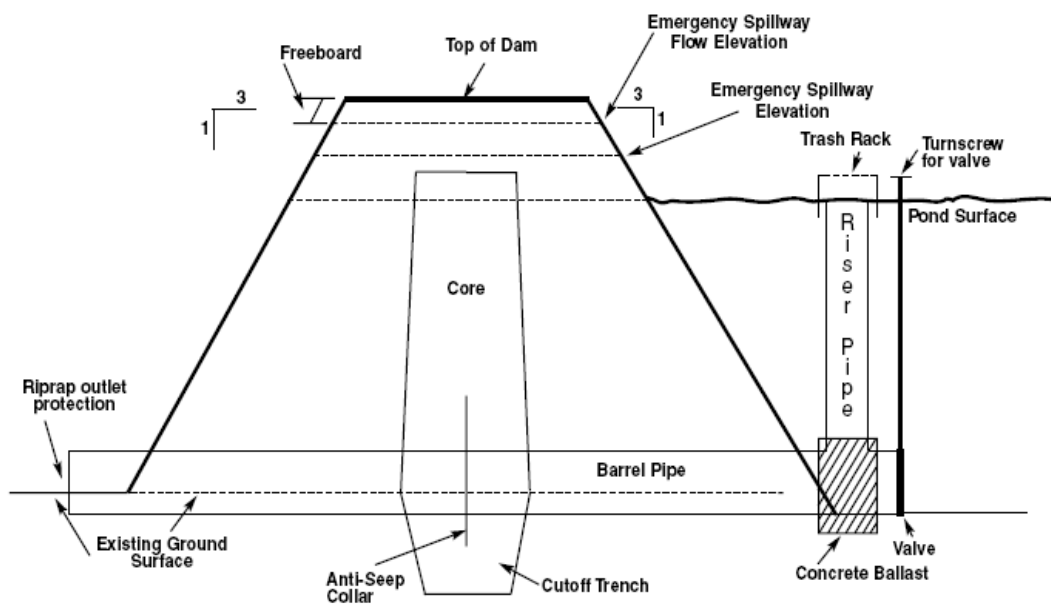
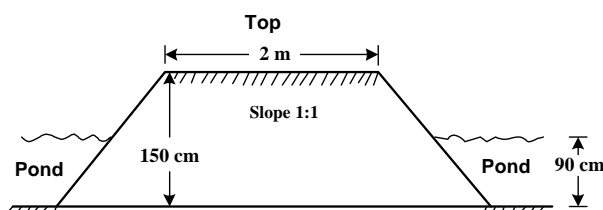
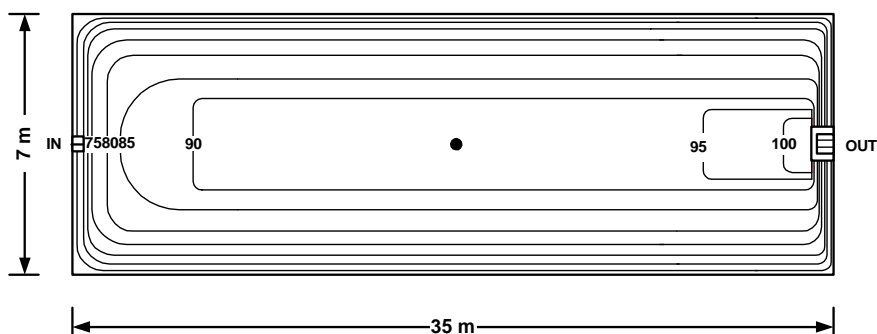

### Hydrology (water budget) of fish pond

Gains	Losses
scheduled filling (f)	scheduled discharge (d)
rainfall (r)	evaporation (e)
seepage (s)	seepage (s)
surface runoff (o)	

$$\text{Water storage} = (f + r + s + o) - (d + e + s)$$

### Equipments needed for monitoring water gains and losses

- Depth gauge
- Rain gauge
- Evaporation pan

### **Pump and water supply system**

This system must be designed based on the water supply available. Where water is plentiful low lift pumps are preferred. The pipe from the pump should be installed in the dike. Valves should open and close easily and permit water flow control to each pond.

### **Drain pipe requirements**

Design of the drain system should be adequate to handle a 20 percent pond flush and can be drained within a few day. A 1,600 squaremeters pond will require a 4 inch outlet pipe. Drain pipe should be installed at the lowest point in the pond. A barrier should be built at the opening to the drain to prevent fish from escaping.

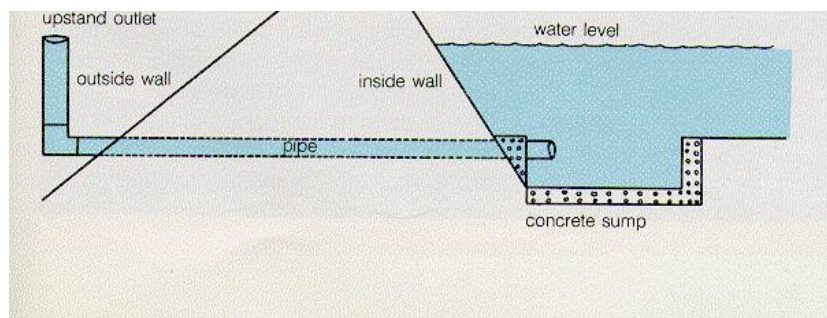

*Outlet (drain) pipe*

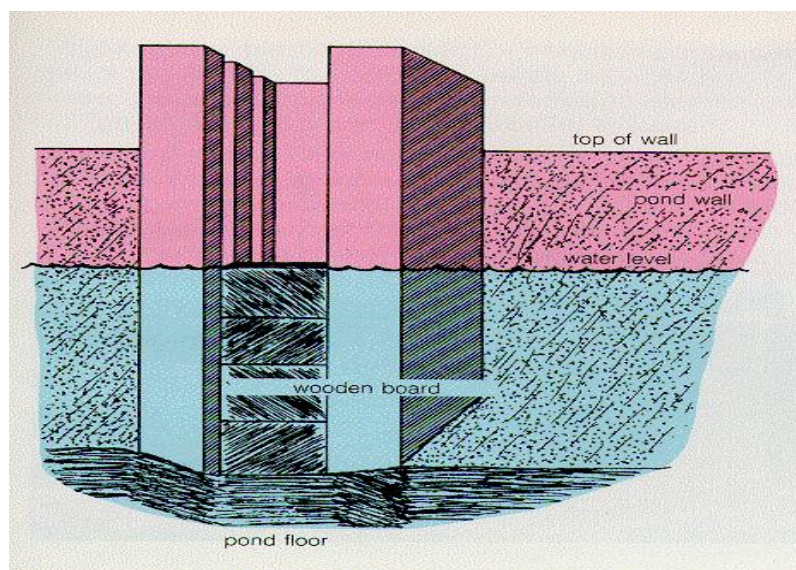

*Water gate*

### **Spillway**

Emergency spillway is required to remove large water quantity of water during heavy rainfall so that water does not flow over the top of the dike. Emergency spillway is variable in width depending on intensity and amount of rainfall, land slope and soil type. A barrier should be stood on spillway to prevent fish from escaping.

## **HATCHERY DESIGN AND COMPONENTS**

Hatchery should be located close water sources so that the distance required to pump water is kept to minimum. Sufficient area need to be available at the site of accommodate the hatchery and ancillary buildings and also to allow for any future expansion.

### Water system (Water treatment area)

High water quality is needed for hatchery. It is important to ensure that the water is treated. So, filtration system and water treatment area are required.

### Broodstock holding and spawning area

Space is required to hold and condition broodstock. The amount of space needed depends in part on the number of species being held. Space is required for spawning pond.

### Larval and juvenile culture area

Another major part of the hatchery is occupied by larval and juvenile rearing facility and dimensions of this area depend on the scale of production. The space is occupied with tanks or concrete ponds, the number needed depending on production levels and techniques used to rear larvae and juveniles.

### Other space requirement

Hatcheries dealing with broodstock from outside the immediate region or with exotic species may be required to quarantine stock and rear progeny in isolation. Other rooms including office, laboratory and storage room are also required.

### Cage design, materials and construction

Cages shape and size depend on the size of water body, the availability of aeration and method of harvest. Cages shape may be round, square or rectangular. Shape does not appear to affect production.

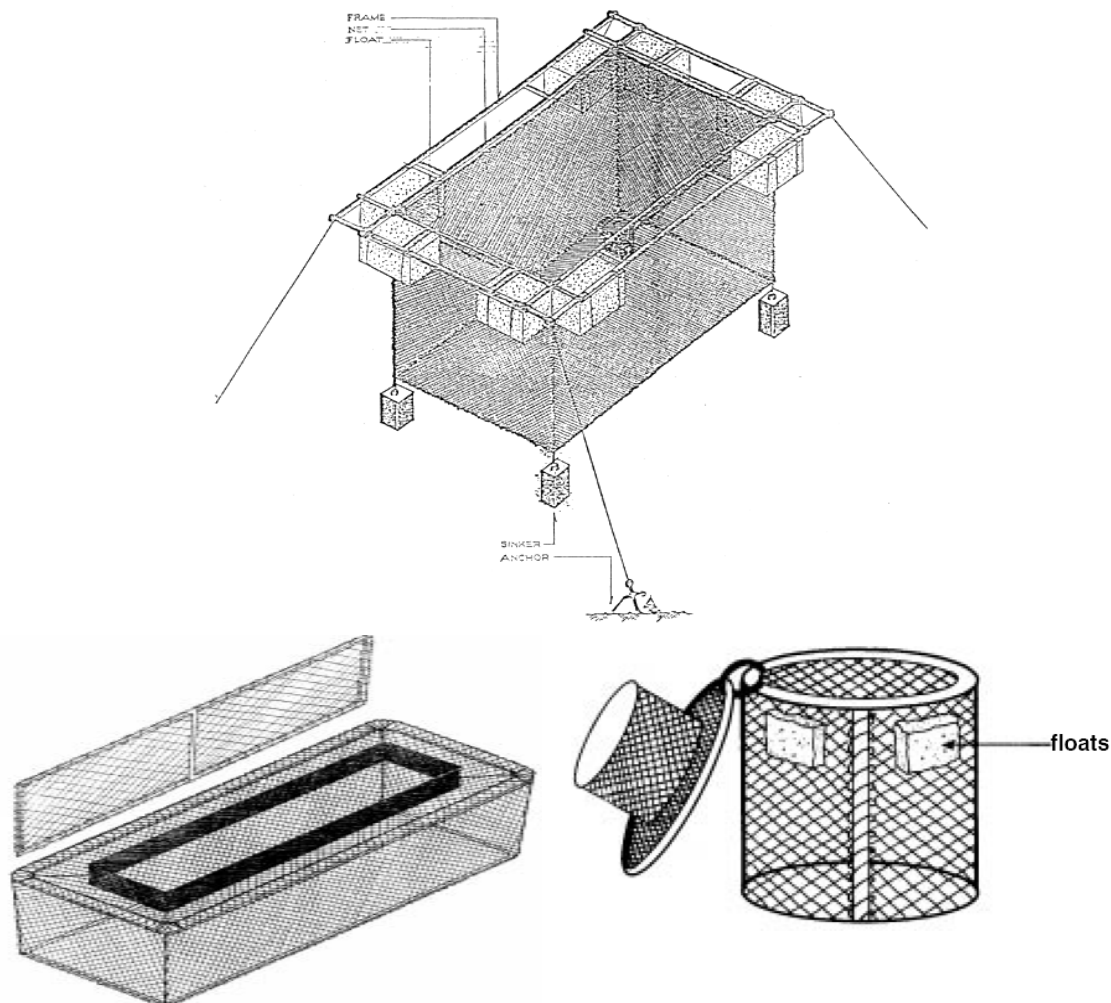

Cages for fish culture have been constructed from a variety of materials. Basic cage construction requires that cage materials be strong, durable, and non-toxic. Cage components consist of frame, mesh or netting, lid and floatation. The frame of the cage can be constructed from wood, iron, steel, aluminum, fiberglass or PVC. Frames of wood, iron, steel should be coated with a water-resistant substance like epoxy or swimming pool paint. Bolts or fasteners used to construct the cage should be of rust-resistant materials. Mesh or netting that can be used include plastic coated weld wire, solid plastic mesh and nylon netting (knotted or knot-less). Mesh size should be suitable for fish size and good water circulation through the cage. All cages should have lids to assure that fish do not escape and that predators do not have access to the cages. All cages also need feeding rings to keep floating feed inside the cages.



## FRESHWATER AQUACULTURE TECHNIQUES FOR RURAL DEVELOPMENT

### Water Management (Supply and Quality)

#### SUBJECT PLAN

<b>Subject</b>	Freshwater Aquaculture Techniques for Rural Development: Principles of Fish Farm Establishment -site selection, pond/cage design and development
<b>Subject</b>	Water Management (Supply and Quality)
<b>Date/Time</b>	3 July 2007, 1330-1500
<b>Officer-in-charge</b>	Dr. Suchart Ingthamjitr
<b>Objectives</b>	One and a half hour lecture will enable participants to understand more on the importance of water for aquaculture, fish pond dynamic, water qualities variation and management for high production and good quality of the culture fish.
<b>Topics</b>	<ol style="list-style-type: none"> <li>1. Introduction of water and aquaculture</li> <li>2. Pond dynamics</li> <li>3. Water quality</li> <li>4. Fertilization and off-flavor</li> </ol>
<b>Detailed Activity</b>	
<b>Time</b>	<b>Sub-activity</b>
<b>3 July 2007</b>	
<b>1330-1350</b>	<p><b>1. Introduction of water and aquaculture</b> Water, the water cycle, water in and on earth as well as some common substances in surface water will be introduced. Aquaculture definition and aquaculture system related to water utilization will be elaborated.</p>
<b>1350-1410</b>	<p><b>2. Pond dynamics</b> Some main factors affecting on changes of water in fish pond such as solar radiation, wind, temperature and water supply will be discussed.</p>
<b>1410-1440</b>	<p><b>3. Water quality</b> Important water qualities of fish pond such as transparency, turbidity, alkalinity, pH, dissolved oxygen and nutrients will be discussed. The optimal value of these parameters to be maintained to keep good fish production will be elaborated.</p>
<b>1440-1500</b>	<p><b>4. Fertilization and off-flavor</b> Relationship of fertilization and fish yield as well as affect on water quality will be explained. Cause and technique to overcome problem of off-flavor will be introduced.</p>



## WATER MANAGEMENT (SUPPLY AND QUALITY)

Suchart Ingthamjitr  
MRC Fisheries Programme

### 1. INTRODUCTION

Water is vital for sustaining life and well being of people. It is also essential for the production of goods and services. People's quality of life, therefore depend on the availability of water.

**1.1 Water:** Water (H<sub>2</sub>O, HOH) is the most abundant molecule on Earth's surface, composing 70-75% of the Earth's surface as liquid and solid state in addition to being found in the atmosphere as a vapor. It is in dynamic equilibrium between the liquid and vapor states at standard temperature and pressure. At room temperature, it is a nearly colorless, tasteless, and odorless liquid.

Many substances dissolve in water and it is commonly referred to as *the universal solvent*. Because of this, water in nature and in use is rarely clean, and may have some properties different than those in the laboratory. However, there are many compounds that are essentially, if not completely, insoluble in water. Water is the only common, pure substance found naturally in all three state of matter.

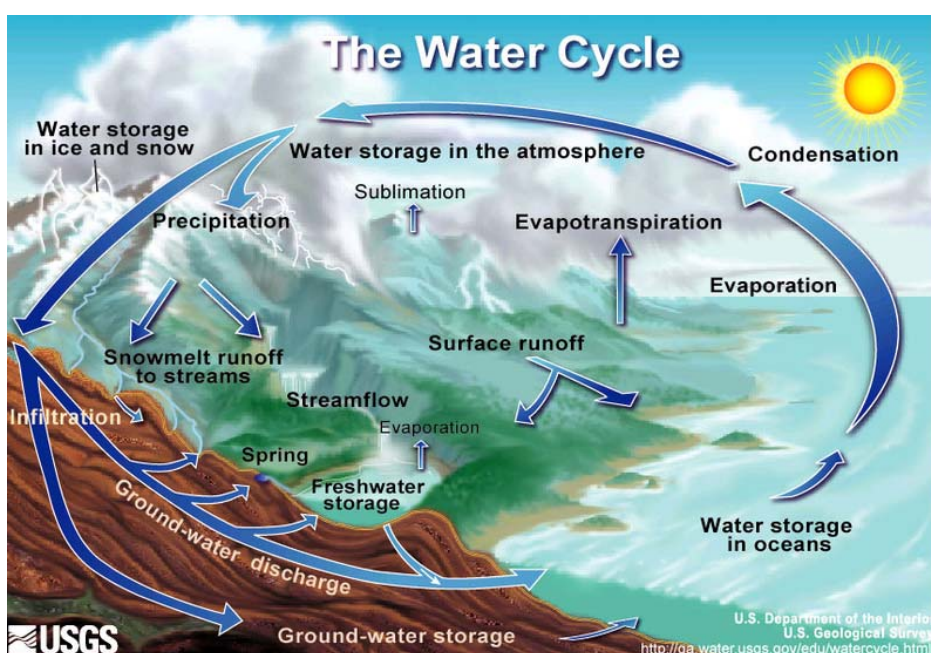

**1.2 Water cycle:** The water cycle has no starting point. But, we'll begin in the oceans, since that is where most of Earth's water exists. The sun, which drives the water cycle, heats water in the oceans. Some of it evaporates as vapor into the air. Ice and snow can sublimate directly into water vapor. Rising air currents take the vapor up into the atmosphere, along with water from evapotranspiration, which is water transpired from plants and evaporated from the soil. The vapor rises into the air where cooler temperatures cause it to condense into clouds. Air currents move clouds around the globe; cloud particles collide, grow, and fall out of the sky as precipitation. Some precipitation falls as snow and can accumulate as ice caps and glaciers, which can store frozen water for thousands of years. Snow packs in warmer climates often thaw and melt when spring arrives, and the melted water flows overland as snowmelt. Most precipitation falls back into the oceans or onto land, where, due to gravity, the precipitation flows over the ground as surface runoff. A portion of runoff enters rivers in valleys in the landscape, with stream flow moving water

towards the oceans. Runoff, and ground-water seepage, accumulate and are stored as freshwater in lakes. Not all runoff flows into rivers, though. Much of it soaks into the ground as infiltration. Some water infiltrates deep into the ground and replenishes aquifers (saturated subsurface rock), which store huge amounts of freshwater for long periods of time. Some infiltration stays close to the land surface and can seep back into surface-water bodies (and the ocean) as ground-water discharge, and some ground water finds openings in the land surface and emerges as freshwater springs. Over time, though, all of this water keeps moving, some to reenter the ocean, where the water cycle ends

**1.3 Water on Earth:** The water cycle (known scientifically as the hydrologic cycle) refers to the continuous exchange of water within the hydrosphere, between the atmosphere, soil water, surface water, groundwater, and plants.

Earth's approximate water volume (the total water supply of the world) is 1,360 million km<sup>3</sup>. Of this volume:

- 1,320 million km<sup>3</sup> (97.2%) is in the oceans.
- 25 million km<sup>3</sup> (1.8%) is in glaciers, ice caps and ice sheets.
- 13 million km<sup>3</sup> (0.9%) is groundwater.
- 0.250 million km<sup>3</sup> (0.02%) is fresh water in lakes, inland seas, and rivers.
- 0.013 million km<sup>3</sup> (0.001%) is atmospheric water vapor at any given time.

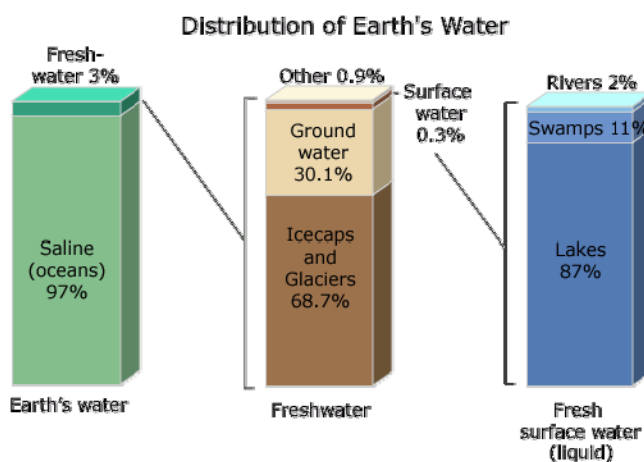

**How much of Earth's water is usable by humans?**

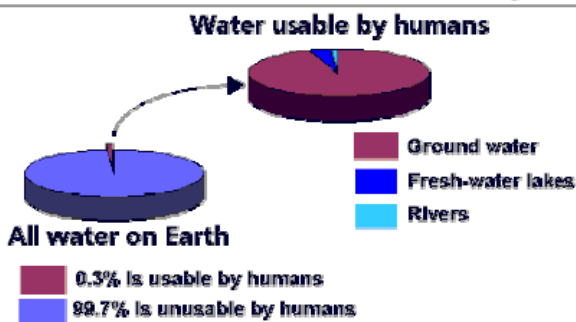

Where is Earth's water located and in what forms does it exist? You can see how water is distributed by viewing these bar charts. The left-side bar shows where the water on Earth exists; about 97 percent of all water is in the oceans. The middle bar shows the distribution of that three percent of all Earth's water that is freshwater. The majority, about 69 percent, is locked up in glaciers and icecaps, mainly in Greenland and Antarctica. You might be surprised that of the remaining freshwater, almost all of it is below your feet, as ground water. No matter where on Earth you are standing, chances are that, at some depth, the ground below you is saturated with water. Of all the freshwater on Earth, only about 0.3 percent is contained in rivers and lakes—yet rivers and lakes are not only the water we are most familiar with, it is also where most of the water we use in our everyday lives exists.

## **2. AQUACULTURE**

**2.1 Definition:** Aquaculture is the farming of aquatic organisms, including fish, molluscs, crustaceans and aquatic plants. Farming implies some form of intervention in the rearing process to enhance production, such as regular stocking, feeding, protection from predators, etc (Pullin, 1993).

The decline of fish communities in inland water due to pollution was particularly marked during the phase of industrialization in the temperate zone and resulted in the disappearance of many species. This tendency has continued into newly industrialize nations, and many of the river countries by a combination of falling water quality and environmental modification.

It has been suggested that aquaculture will expand to compensate for shortfalls from catches. Certainly, the present trend, with aquaculture as the only fishery sector to be increasing, would appear to support this contention. The continuing rise in production from aquaculture is paralleled by a diversification of the sector, with more and more species entering culture systems.

Aquaculture, like all food production by farming, has large effects on the environment, many of which can be negative: occupation and fragmentation of former natural habitats; reduction of the abundance and diversity of wildlife and changes in soil, water and landscape quality. Because farming will remain the mainstay of most developing country economies for the foreseeable future and will cause much environmental change, it is essential that the potential negative effects of further development of aquaculture be thoroughly appraised. Environmental protection and nature conservation now have much higher profiles in the political arena, mass media and public awareness than before. Environmental impacts at the relatively new frontier of aquaculture need very careful attention (Pullin, 1993).

Intensive aquaculture (in effect, using the feedlot principle) usually poses much greater threats to the environment than does extensive or semi-intensive aquaculture. Intensive fish farms are often heavy users of antibiotics and disinfectants and their operators need to be aware of the dangers of release of such chemicals to the natural environment including the possibilities of producing drug-resistant. Pollution by intensive aquaculture is well known. Fish fecal wastes and uneaten food in effluents from fish farms and in settlement from cages have high biological oxygen demands (BODs) and contain large quantities of particulate matter and nutrients (Pullin, 1993).

### **2.2 Intensity of Farming Systems** (Selected from Edwards, 1993)

a). Extensive Systems rely on natural feed produced without intentional inputs. By definition they are excluded from integrated farming systems except for integrated rice fish farming in which fish may derive benefits from inputs added solely for rice.

b). Semi-intensive systems depend on fertilization to produce natural feed in situ and/or on feed given to the fish, supplementary feed, to complement the natural feed which develops. A significant amount of the fish nutrition is derived from natural feed. Integrated crop-livestock-fish farms and wastewater-fed fishponds have semi-intensive pond systems.

c). Intensive systems depend on nutritionally complete feeds, either in moist formulations or in dried pelleted form, with fish deriving little to no nutrition from natural feed produced in situ.

The degree of intensification is defined according to feeding practice but intensification may be accompanied by increasing amounts of capital, labor and mechanization. Intensive aquaculture has the highest nutrient conversion efficiencies because feed is ideally formulated according to the nutritional needs of the target species. Nutrient conversion efficiencies in term of nutrient inputs and nutrients in fish range of 21-53% for N and 11-28% for P with food conversion ratios (FCR) of 1.0-2.5, respectively. Nitrogen and phosphorus conversion efficiencies of semi-intensive systems are 5-25% and 5-11%, respectively (Edwards, 1993).

The estimated volume of water need for extensive, semi-intensive and intensive culture system assume mean pond depth of 1 m

System	Production(t/ha/year)	Water (m3/t)
Extensive	0.3-0.8	44,000-233,000
Semi-intensive	1.0-5.0	7,000-70,000
Intensive	3.0-8.0	4,000-23,000

### 3. FISH POND DYNAMICS

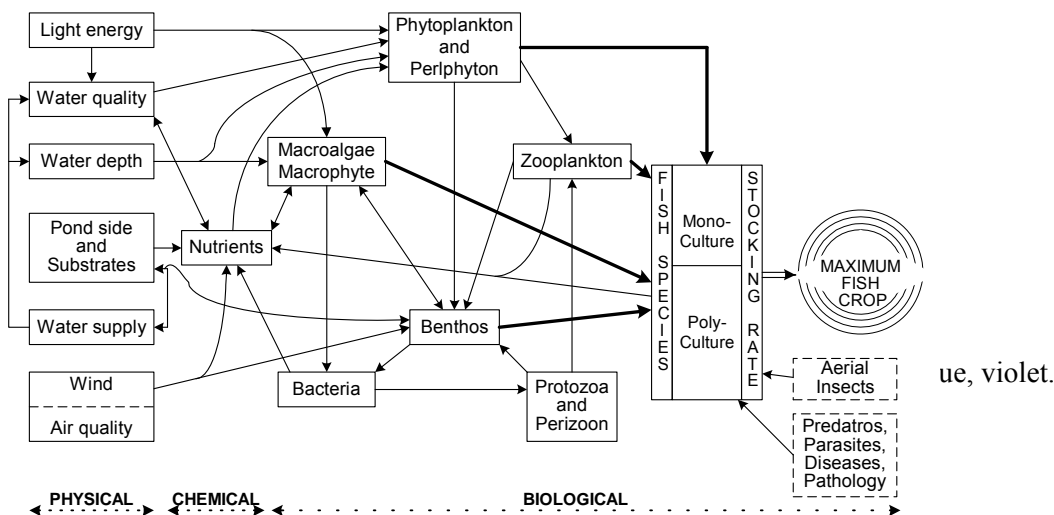

#### 3.1 Light energy

Spectral distribution: Ultraviolet, visible and infrared

Visible region: 400 - 700 nm, including red, orange, yellow, green, blue, violet.

Photosynthetic active radiation (PAR)

$$\text{Light penetration} = \text{Incident light} - (\text{reflection} + \text{absorption} + \text{scatter})$$

**Reflection:** Direct solar radiation reaching the water surface varies with the angular height of the radiation and, therefore, with time of day, season, and latitude. A significant portion of the light is reflected by the surface of the water.

**Absorption:** Diminution of light energy with increasing depth by transformation to heat. Influenced by the molecular structure of water itself, by particles suspended in the water, and especially by dissolved organic compounds. Over half of the solar radiation that penetrates into water is absorbed and dissipated as heat.

**Scatter:** Composite of reflection from a massive array of angles existing internally within a water. The extent of scattering in a specific volume of water varies greatly with the distribution of inorganic and organic suspended matter and proximity to sediments.

Measurement is done by using visibility or transparency with a Secchi disc or by using underwater photometer.

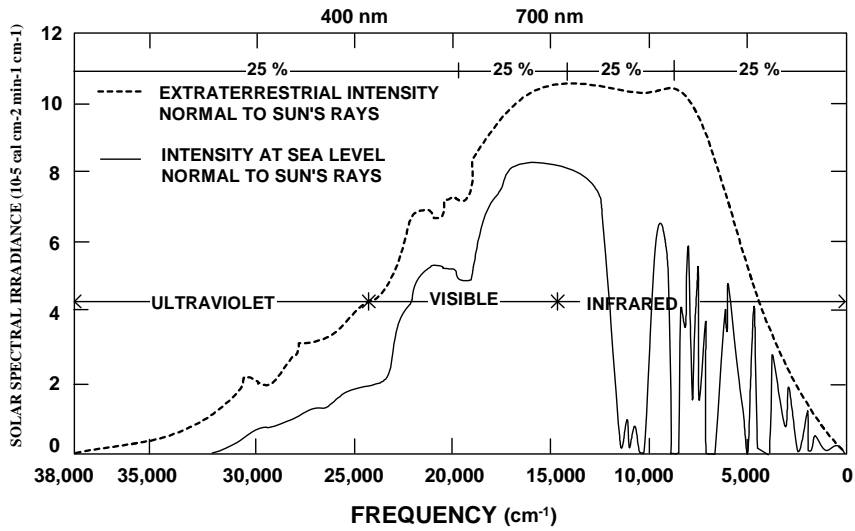

### 3.2 Wind and air quality

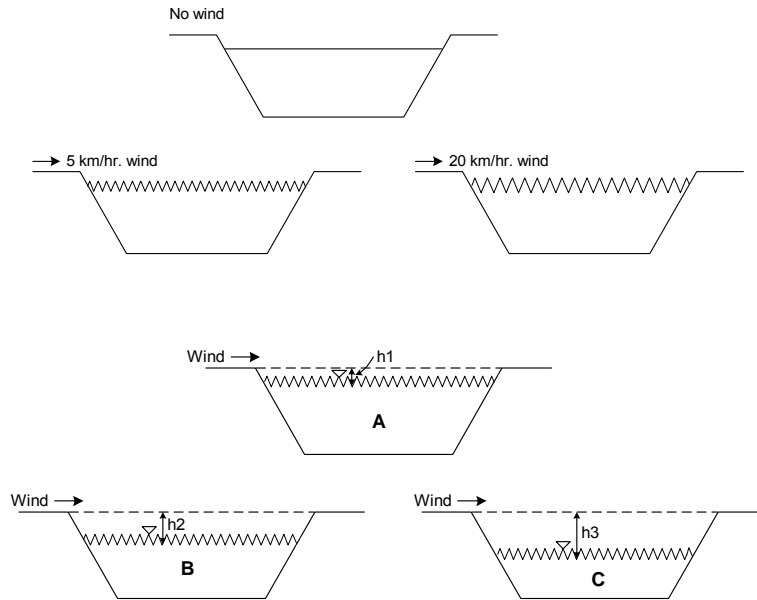

Wind effect A>B>C



Credit: Tennessee Valley Authority (TVA)

Pure water has a pH of 7, and, generally, rainfall is somewhat on the acidic side (a bit less than 6). But, acid rain can have a pH of about 5.0-5.5, and can even be in the 4 range in the northeastern United States, where there are a lot of industries and cars.

Acid rain is a uniquely human-related phenomenon. The burning of fossil fuels (coal and oil) by power-production companies and industries releases sulfur into the air that combines with oxygen

to form sulfur dioxide (SO<sub>2</sub>). Exhausts from cars cause the formation of nitrogen oxides in the air. From these gases, airborne sulfuric acid (H<sub>2</sub>SO<sub>4</sub>) and nitric acid (HNO<sub>3</sub>) can be formed and be dissolved in the water vapor in the air. Although acid-rain gases may originate in urban areas, they are often carried for hundreds of miles in the atmosphere by winds into rural areas. That is why forests and lakes in the countryside can be harmed by acid rain that originates in cities.

### 3.3 Water supply



Source: <http://www.archives.gov>

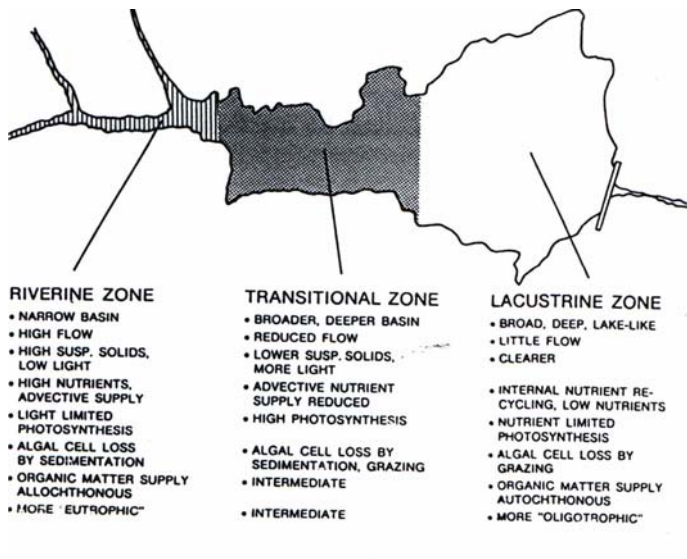

#### 3.3.1 Pond side and substrate

##### Source of nutrients

- Source water: waters with high alkalinity normally possess, greater concentrations of dissolved minerals.
- Sedimentary regeneration
- Artificial fertilization

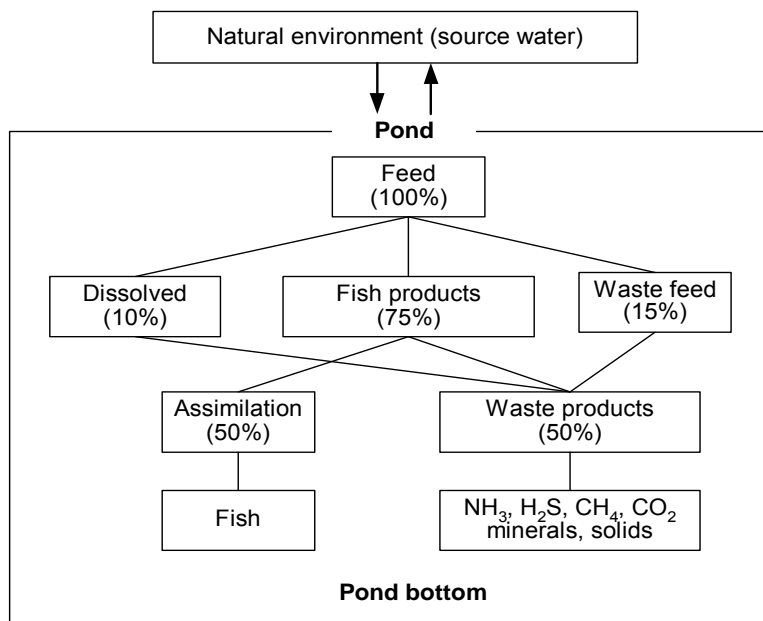

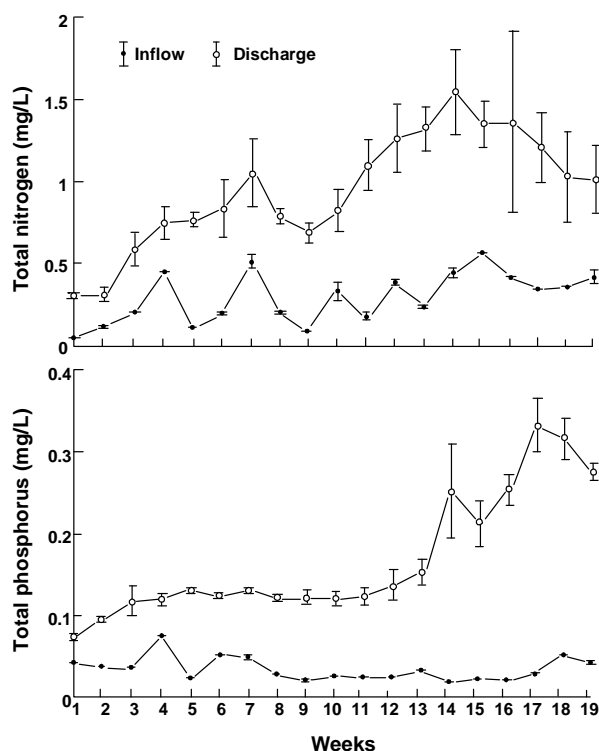

*Change in P and N concentrations in intensive shrimp ponds.*

**Uneaten Foods:** In both semi-intensive and intensive aquaculture, food is provided. A proportion remains uneaten because of quantities and quality are often inappropriate and because aquaculture systems and their management tend to confound optimization of ingestion. Study indicates that the proportion of uneaten food varies from around 1% to as much as 30% and confirms that system, type of feed and management are important determinants of wastage. Available data suggest that feed losses associated with pelleted feed are less than for trash fish (although if the dry matter content of feeds is taken into account, the significance of these differences is negligible) and that the proportion of uneaten food in cages is considerably greater than those from tanks or ponds.

**Excreta:** The undigested fraction of feed, together with mucus, sloughed intestinal cells and bacteria, is voided as feces whilst the digested portion is absorbed and metabolized. Nutrients absorbed in excess to requirements may be excreted together with end-products (ammonia and urea) derived from the catabolic breakdown of protein for energy purposes.

It is possible to estimate the fecal production associated with a diet from digestibility data on the principal constituents. Although this approach necessarily ignores the effects of variables such as temperature, body size, health, feeding rate and the synergistic/antagonistic effect of one dietary component on the digestibility of another, such estimates have been found to approximate those obtained by direct measurement.

### **Artificial fertilization**

**Fertilization:** To stimulate phytoplankton production, thereby increase fish food organisms and fish yield.

**Fertilizers:**

- Inorganic fertilizers stimulate primarily autotrophs and related food chain organisms
- Organic fertilizers act on heterotrophs and autotrophs

Inorganic fertilizers supplement to organic fertilizers: As animal wastes often contain nitrogen and phosphorus concentrations that are not in balance as required for optimal phytoplankton production, it is necessary to supplement the manures with inorganic fertilizer source (N/P) to make the more desirable ingredients.

Fertilizer application rate and frequency:

As the complication relating to the effectiveness of fertilization discussed above, it is difficult to offer a set of quantitative formula for fertilization rate applicable to all situations. In general, to maintain a level of phytoplankton production at 20-40 cm. Secchi disc depth (@80-300 mg chl a / m<sup>3</sup>), the total P and N concentrations in the water column should be kept at a range of 0.2-0.5 mg P/L and 1-3 mg N/L, with a N:P ration of 5-10:1. In principle, greater frequency of fertilization gives greater stability of nutrient concentration level in water thus maintain even stable biological productivity. In practice, twice per week to weekly application is adequate frequency.

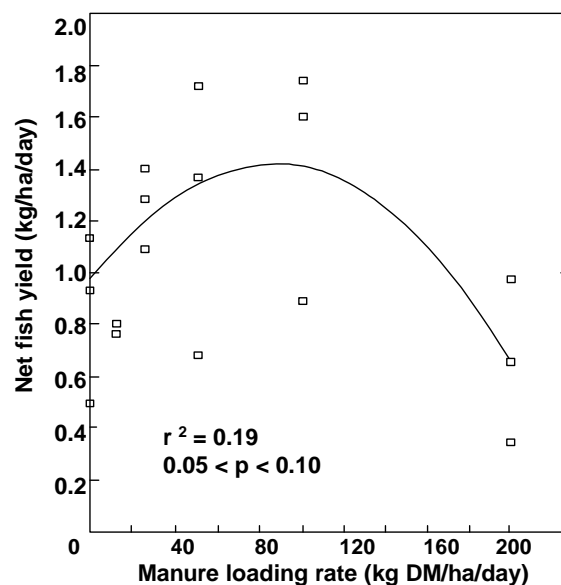

### Off-Flavor

Off-flavor fish make taste muddy, weedy, or rancid, making fish product unmarketable or offered at low price.

Chemical compounds cause off-flavor:

- Geosmin (C<sub>12</sub>H<sub>22</sub>O),
- Methyhsobomeol (MIB, C<sub>11</sub>H<sub>20</sub>O),
- Mucidone (C<sub>16</sub>H<sub>18</sub>O<sub>2</sub>)
- Threshold concentration for off-flavor is <1 µg/kg fish

The compounds may occur in the water, mud, microorganisms, and fish; can be extracted by distillation and separated by methylene and analyzed by gas-liquid chromatography. Fish take up the off-flavor compounds from gills and transferred to blood throughout the body, or from food ingestion.

Organisms produce off -flavor substances:

- Blue-green algae: *Anabacna scheremetievi*, *Lyngbya best*, *Oscillatoria agardhii*, *O. bornetii fa.* *Tenuis*, *O. cortiana*, *O. prolifica*, *O. simplicissima*, *O. splendida*, *O. tenuis*, *O. variabilis*, *Schizothrix muelleri*, *Symplow muscorum*, *Lyngbya cryptovaginata*, *Oscillatoria curviceps*, *O. tenuis* var. *levis*
- Fungi: (Actinomycetes - *Streptomyces* spp.)



### Environmental conditions influence off-flavor organism growth

- High organic matter in the ponds that provide substrate for fungal growth.
- *Streptomyces* spp. can be inhibited by low D.O. content in the ponds
- The walking catfish and snakehead grown in low D.O. with little phytoplankton growth seldom have off-flavor problem.
- The optimal temperature for off-flavor causing organisms ranged from 25-30°C
- Alkaline water and soil favor growth of off-flavor organisms.

### Preventive measures for off-flavor problems

- Avoid accumulation of organic in the pond bottom.
- Prepare pond bottom by removing excessive organic matter and through sun dry.
- Chemical compounds to control off-flavor organisms - CuSO<sub>4</sub>, Simazine.
- NaCl (10 mg/L) inhibits *Streptomyces* growth.
- Sea fish have few off-flavor incidence.

### 3.3.2 Water depth

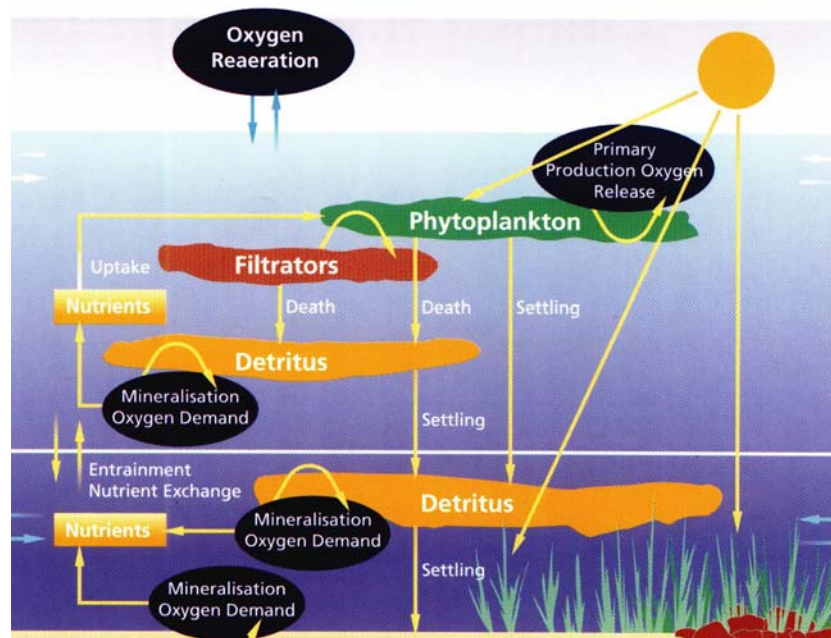

### 3.3.3 Water quality

#### a) Temperature

Temperature affects on feeding, reproduction, immunity, and the metabolism of aquatic animals. Drastic temperature changes can be fatal to aquatic animals. Not only do different species have different requirements, but optimum temperatures can change or have a narrower range for each stage of life.

All species tolerate slow seasonal changes better than rapid changes. Thermal stress or shock can occur when temperatures change more than 1-2 °C in 24 hours. The heat capacity of water is very high, making it resistant to changes in temperature. This moderates the daily and seasonal climatic changes in temperature. But cooling is often impractical and heating is possible but costly. Water temperature is an important variable in many chemical tests and electronic measures for water quality. Many determinations require adjustment for the temperature or noting the temperature at the time of sampling.

Water temperature affects many biological chemical processes. Spawning is triggered by temperature. Temperature differences between the surface and bottom waters help produce vertical current moving nutrients and oxygen throughout the water column. Temperature influences the solubility of oxygen and the percentage of unionized ammonia in water.

**Gains:** solar radiation + water inflow + geoheat

**Losses:** reflection + evaporation + water outflow + substrate

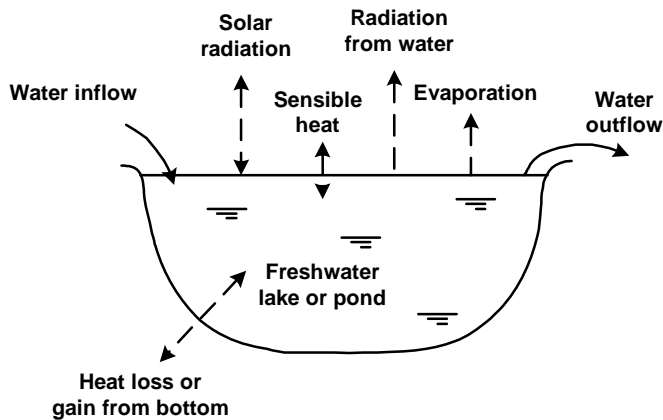

*Thermal energy flow in aquatic environment*

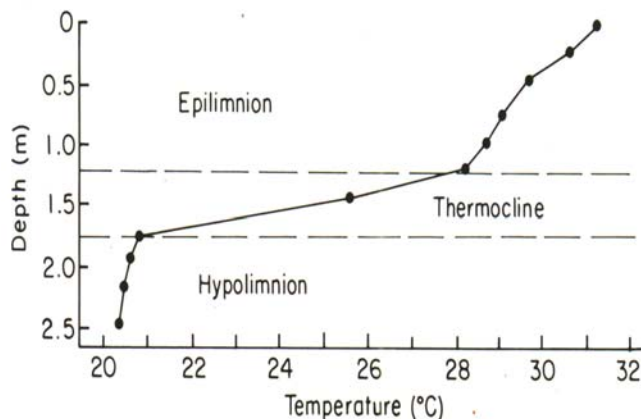

**b) Transparency**

Although the measurement of extinction coefficients and spectral characteristics of underwater irradiance is commonly done with photometer, an approximate evaluation of transparency of water can be made with a Secchi disc. The Secchi disc is a weighted white disc, 20 cm in diameter.

Transparency, estimated in this way, is the mean of the depths at which the Secchi disc disappears when viewed from the shaded side of the boat and at which it reappears upon rising after it has been lowered beyond visibility.

Secchi disc transparency is basically a function of reflection of light from the surface of the disc and is therefore affected by the absorption characteristics of the water and of dissolved and particulate matter contained in the water.

High concentrations of organic matter decrease transparency in a nonlinear way as measured with Secchi disc, reduction in light transmission as evaluated by the disc is influenced strongly by increased scattering of light by suspended particulate matter.

**c) Alkalinity and Hardness** (Selected from Parker, 1995)

This is a measure of the basic substances of water. Because in natural water these substances are usually carbonate and bicarbonate the measurement is expressed as mg/L of equivalent calcium carbonate. In some cases, such as many groundwater and western ponds, sodium carbonate is the predominant basic substance. These basic substances resist change in pH (buffering) and where an abundance of calcium and magnesium bicarbonate is dissolved the pH will stabilize between 8 and 9. Some laboratory forms report carbonate ( $\text{CO}_3^{2-}$ ) and bicarbonate ( $\text{HCO}_3^-$ ) in addition to total alkalinity. These are typically derived from alkalinity measurement by multiplication by standard conversion factors.

Total hardness is the measure of the total concentration of primarily calcium and magnesium expressed in milligram per liter (mg/L) of equivalent calcium carbonate ( $\text{CaCO}_3$ ). Calcium and magnesium are usually present in association with carbonate as calcium carbonate or magnesium carbonate. Total hardness relates to total alkalinity and indicates the water's potential for stabilizing pH. Water can be high in alkalinity and low in hardness if sodium and potassium are dominant. Table below lists water hardness classifications as mg/L of  $\text{CaCO}_3$ .

Water Hardness Levels (Parker, 1995)

Water hardness	mg/L $\text{CaCO}_3$
Soft	0-20
Moderately soft	20-60
Moderately hard	61-120
Hard	121-180
Very hard	>180

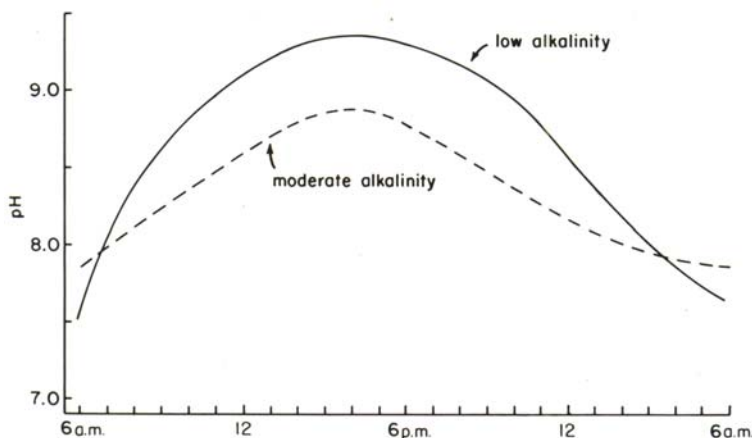

**d) pH**

The pH is one of the most common water tests-is a measure of hydrogen ions in the water. The pH scale spans a number of ranges of 0-14 with the number 7 being neutral. The pH scale is logarithmic, so every one-unit change in pH represents a ten-fold change in acidity. Measurement above 7 is basic and below 7 is acidic. The farther a measurement is from 7, the more basic or acidic is the water. Acid and alkaline (basic) death points for fish are approximately pH 4 and 11. Growth and reproduction can be affected between pH 4-6 and 9-10 for some fishes. Also, pH affects the toxicity of other substances, such as ammonia and nitrite.

The pH of some ponds may change during the course of a day and is often between 9 and 10 for short periods of afternoons. Fish can usually tolerate such rises that result when carbon dioxide, and acidic substance, is used up by plants in photosynthesis. The most common pH problem for

pond fish is when water is constantly acidic. The nature of the bottom and watershed soil is usually responsible. Water with a stable and low pH is only correctable with liming.

**e) Dissolved Oxygen (D.O.)** (Selected from Parker, 1995)

Aquatic life requires D.O. It varies greatly in natural surface water and is characteristically absent in ground waters. Most aquatic animals need more than a 1 mg/L concentration for survival. Depending on culture circumstances, aquatic animals need 4-5 mg/L to avoid stress. Concentrations considered typical for surface water are influenced by temperature but usually exceed 7 to 8 mg/L. In ponds, dissolved oxygen fluctuates greatly due to photosynthetic oxygen production by algae during the day and the continuous consumption of oxygen due to respiration. D.O. typically reach a maximum during the late afternoon and a minimum around sunrise. Cloudy weather, rain, plankton die-off, and heavy stocking and feeding rates result in low levels of dissolved oxygen, which can stress or kill fish.

Oxygen is only slightly soluble in water. Water may be frequently supersaturated with oxygen in ponds with algae blooms. For example, at sea level at temperature of 77.F (25.C), pure water contain about 8 mg/L of oxygen when 100 percent saturated, but during the afternoon hours, levels of 10 to 14 mg/L in ponds with healthy algae blooms are not uncommon.

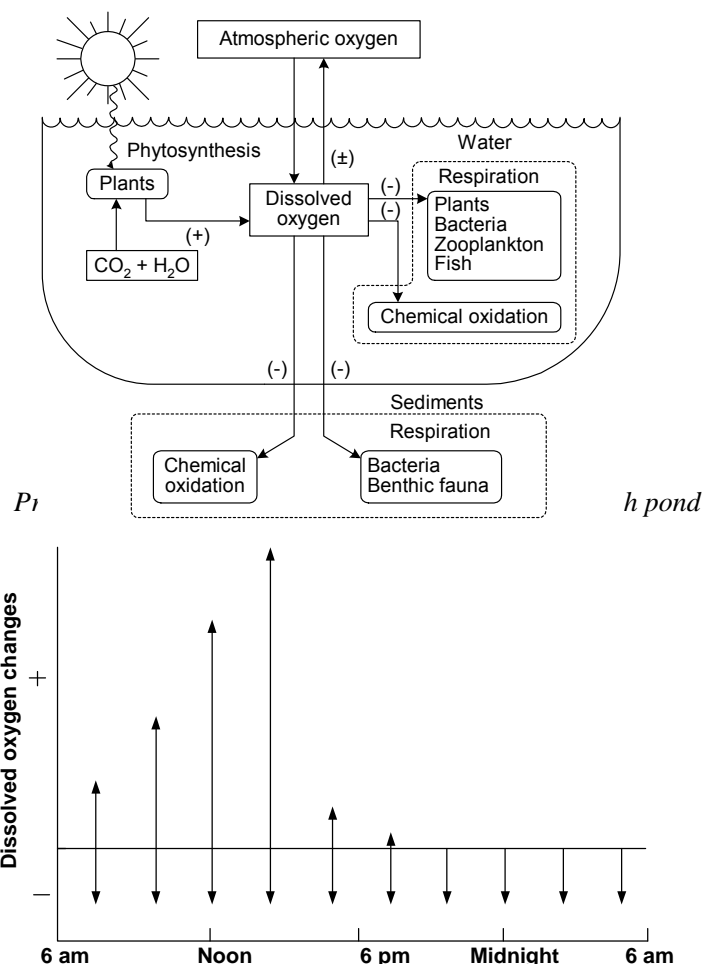

As water warms, is raised to higher altitudes, become more saline, its oxygen holding capacity declines. Water saturated with oxygen at 59.F (15.C) contains about 9.8 mg/L, while water at 86.F (30.C) is saturated at about 7.5 mg/L.

Guidelines for oxygen management usually report that oxygen levels should be maintained above 4 mg/L to avoid stress. Most warmwater fish experience significant oxygen stress at levels of 2 mg/L, and that levels of less than 1 mg/L may result in fish kills. While these guidelines are accurate, fish actually respond to the percent saturation of oxygen rather than the oxygen content in water. A reading of 1 mg/L at 30.C (13.3 percent saturated) is a higher concentration than 1 mg/L at 15.C (10.2 percent saturated) and represents more available oxygen.

If dissolved oxygen reaches low levels, fish will show signs including;

- Not eating and acting sluggish
- Gaspings for air at the surface
- Grouped near water inflow pipe
- Slow growth
- Outbreaks of disease and parasites.

Proper water management prevents the problems from depletion of dissolved oxygen. Management techniques include;

- Monitoring dissolved oxygen at critical times
- Avoiding overfeeding
- Proper stocking level
- Avoiding over-fertilization
- Controlled plant growth
- Some form of aeration
- Keeping water circulation

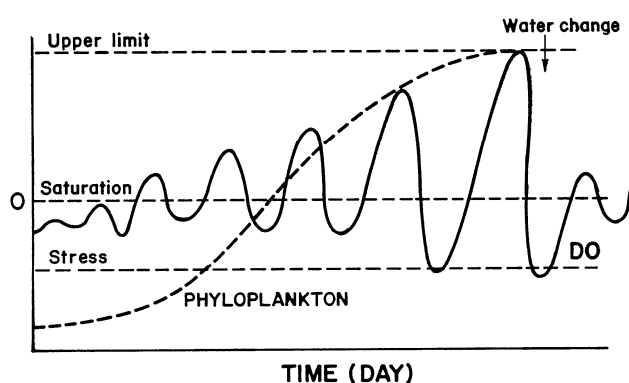

**f) Carbon dioxide (CO<sub>2</sub>)** (Selected from Parker, 1995)

Carbon dioxide (CO<sub>2</sub>), a minor component of the atmosphere, is slightly soluble in water. Most carbon dioxide in pond water occurs as a result of respiration. Levels usually fluctuate inversely to dissolved oxygen, being low during the day and increasing at night, or whenever respiration occurs at a greater rate than photosynthesis.

Carbon dioxide is present in surface water at less than 5 mg/L concentrations but may exceed 60 mg/L in many well waters and 10 mg/L where fish are maintained in large numbers. Some aquatic animals, including fish can endure stress and survive at up to 60 mg/L. If oxygen is lowered into its stress-causing range, carbon dioxide limitation is reduced to 20 mg/L.

Carbon dioxide interferes with the ability of the aquatic animals to extract oxygen from water, contributing to stress of fish during periods of low oxygen. Aerating water to improve its oxygen content drives off excess carbon dioxide.

Adding quick lime, Ca(OH<sub>2</sub>) to water rapidly removes carbon dioxide without affecting oxygen content. This improves the ability of fish to use the available oxygen. Carbon dioxide acts as an acid in water, lowering pH as it increases in concentration. Carbonate buffers in water neutralize carbon dioxide and stabilize pH fluctuations within the range tolerated by fish. Water low in

alkalinity and hardness may experience extremes of pH due to its poor buffering against changes in carbon dioxide concentrations.

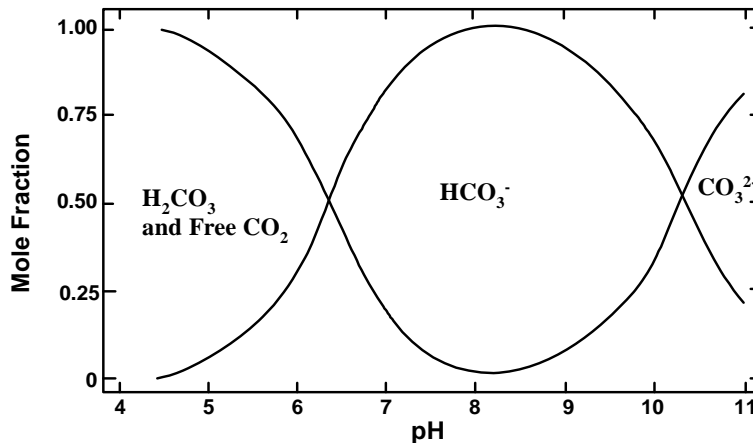

*Effect of pH on the relative proportion of H<sub>2</sub>CO<sub>3</sub> and free CO<sub>2</sub> (total CO<sub>2</sub>), HCO<sub>3</sub><sup>-</sup>, and CO<sub>3</sub><sup>2-</sup> (Boyd, 1988).*

#### g) Hydrogen Sulfide (H<sub>2</sub>S) (Selected from Parker, 1995)

Hydrogen Sulfide, rotten-eggs gas, is present in some well waters but is so easily oxidizable that exposure to oxygen rapidly converts it to harmless form. Its toxicity depends on temperature, pH, and dissolved oxygen. Any measurable amount after providing reasonable aeration could be considered to have potential to harm fish life.

Hydrogen sulfide occurs in ponds as a result of the anaerobic decomposition of organic matter by bacteria in mud. Hydrogen sulfide is toxic to fish and interferes with normal respiration. Toxicity is increased at higher temperatures and a pH less than 8 when the largest percentage of hydrogen sulfide is in the toxic unionized form. Vigorous aeration or splashing is usually sufficient to remove hydrogen sulfide from well water.

In ponds, hydrogen sulfide can be released from anaerobic mud when the bottom is disturbed by seining and harvest activities. Liming ponds raises mud pH and reduces the potential for the formation of H<sub>2</sub>S. Potassium permanganate at 2 to 6 mg/L removed H<sub>2</sub>S from water and reverses the effects of its toxicity to fish.

#### h) Ammonia (NH<sub>3</sub>) (Selected from Parker, 1995)

Ammonia is present in slight amounts in some well and pond waters. As fishes become more intensively cultured or confined, ammonia can reach harmful levels. Any amount is considered undesirable, but stress and some death loss occurs at more than 2 mg/L, and at more than 7 mg/L fish loss increases sharply.

Ammonia is waste product of protein metabolism by aquatic animals. In water, ammonia occurs either in the ionized (NH<sub>4</sub><sup>+</sup>) or unionized (NH<sub>3</sub>) form, depending on pH. Unionized ammonia is considerably more toxic to fish and occurs in greater proportion at high pH and warmer temperatures. For example, at 82.4.F (28C) and pH 8,

6.55 percent of the total ammonia is present in ionized form. At pH 9, 41.23 percent of the ammonia is unionized. Unionized ammonia is stressful to warm water fish at concentrations greater than 0.1 mg/L and lethal at concentrations approaching 0.5 mg/L. Concentrations of 0.0125 mg/L cause reduces growth and gill damage in trout. Algae use ammonia as a nitrogen source for making proteins. Concentration usually remains low in ponds with phytoplankton blooms. The greatest concentration of ammonia often occurs after phytoplankton die-offs, at which time pH is

low due to high levels of carbon dioxide, and the majority of ammonia is present in the relatively nontoxic ionized form.



## FRESHWATER AQUACULTURE TECHNIQUES FOR RURAL DEVELOPMENT

### Natural Food and Fish Feeds

#### SUBJECT PLAN

<b>Subject</b>	Natural Food and Fish Feeds
<b>Date/Time</b>	3 July 2007, 14.45-16.30 hrs
<b>Officer-in-Charge</b>	Choltisak Chawpaknum
<b>Objectives</b>	After the subject, The participants will be able to: <ol style="list-style-type: none"> <li>1. Understand principles of Natural Food preparation in pond</li> <li>2. Understand principles of Fish nutrition and feed formulation</li> </ol>
<b>Topics</b>	<ol style="list-style-type: none"> <li>1. The important of Natural Food for fish fry</li> <li>2. The fertilizers for fish pond</li> <li>3. Fundamental of Fish nutrition</li> <li>4. Principle of Feed formulation</li> </ol>
<b>Detailed Activity</b>	
<b>Time</b>	<b>Sub-activity</b>
<b>3 July 2007</b>	
<b>14.45-15.00</b>	<b>1. The important of Natural Food for fish fry</b> Biological characteristics of fish fry and fingerling are the basic knowledge for nursing and growth out, especially in feeding habits. They are needed to get natural food for height survival rate.
<b>15.00-15.30</b>	<b>2. The fertilizers for fish pond</b> The main of natural food are phytoplankton, zooplankton and small aquatic animal. The fertilizers are supplier of nutrients for photosynthesis in phytoplankton. The several kinds of manures and methods of application.
<b>15.30-15.50</b>	<b>3. Fundamental of Fish nutrition</b> The macro nutrients for fish are protein, fat and carbohydrate and micro nutrient are mineral and vitamin. It's should be suitable in quality and quantity
<b>15.50-16.30</b>	<b>4. Principle of Feed formulation</b> The rural aquacultures are lack to be get good quality ingredient for feed mixed. They can use local ingredient and calculate by square method for feed formulation.



## NATURAL FOOD AND FISH FEEDS

*Choltisak Chawpaknum*  
*Inland Fisheries Research and Development Bureau*  
*Department of Fisheries, Thailand*

### THE IMPORTANT OF NATURAL FOOD FOR FISH FRY

Rearing fry and fingerlings is to nurture 3 or 4-day-old postlarvae, which start to eat food, into fingerlings for stocking in grow-out ponds. It is generally divided into two stages: at the first stage, fry are cultured for 18–25 days to a body length of 3 cm. At the second stage, fry are reared for another 3-5 months to fingerlings with a body length of 8-20 cm. Most of the grow-out ponds are stocked with fingerlings, but sometimes with some two-year-old fingerlings.

At fry and fingerling stage, especially at fry stage, fish are not only delicate and small, but their power of movement and their ability to feed are weak. Their diet is restricted to a number of items and they have very low adaptive power to changes in environmental conditions and have little power to escape from enemies. They, on the other hand, have a high metabolism. Careful management should therefore be performed to raise the survival rate of fry and fingerlings and to produce healthy and desirable-sized fingerlings.

### BIOLOGY OF FRY AND FINGERLINGS

Fish have a fast growth during fry and fingerling stage and their biological characteristics are different from that of the adults, especially in feeding habits, growth and habitus.

#### 1. Food intake

Because of fry and fingerling are changes their feeding organs, feeding patterns and food composition All in all, animal feedstuff is considered to be of great importance for fry and fingerlings. They have a higher metabolic intensity, faster growth and greater food intake, but all these are relatively declining with the increase of their body weight. The amount of their food intake varies with kinds of food and water temperature, etc. at different developmental stages. Under the optimum temperature, the maximum daily food intake of Grass carp fingerlings comes to 49.9% of its body weight, but only 16.8% and 16.4% for Silver carp and Bighead respectively. It is reported that the daily food intake of juvenile Grass carp is 32-71% and the diurnal variation of food intake is as follows: juvenile Grass carp have a maximum food intake at 8:00 and 16:00 and it increases in the evening while the maximum food intake of Silver carp and Bighead fingerlings is between 12:00-20:00 and it declines after 20:00. Silver carp and Bighead stop eating between 24:00 and 06:00 and the intensity of food intake is rising obviously after 08:00. The retention time of food in the gut of fry and fingerlings is related to the water temperature. It is shown by the experiment that rotifera and *Daphnia* *Bosmina longirostris* fed to Grass carp fry and fingerlings remain in the gut for an hour and a half to three hours and twenty minutes at water temperature of 20–22°C. When the water temperature reaches to 30–32°C, foods are digested in less than one hour. The food in Silver carp's gut is digested in one hour and twenty minutes at water temperature of 22–26°C and even within one hour when the water temperature is 30°C.

#### 2. Growth rate

Fry and fingerlings of various species have different growth rates. Even the same species also have different growth rates at different developmental stages. At fry and fingerling stage, Black carp, Grass carp, Silver carp and Bighead all have a high growth rate, but from fry to summerlings, their relative growth rate is at its maximum, which is the peak in their life span. Particularly, the relative growth rate is much higher between 3 and 10 days after stocking and the daily growth rate is 15-

25% in length and 30–57% in weight. Based on the measurement, within 10 days after being stocked in ponds, the body weight of fry would be double 6 times for Silver carp and 5 times for Bighead. On an average, it is double the previous weight every two days. But fish during this period are small in size and therefore, the absolute increase of their body weight is rather low. The average daily increase in body weight is only between 10 and 20 mg and the average daily increase in body length is 0.71 mm for Bighead and 1.2 mm for Silver carp. (Table 1)

**Table 1.** Growth Rate of Silver carp and Bighead Fry

Species	Bighead		Silver carp	
	Age	Body length	Body weight	Body Length
2	8.1	4	7.2	3
4	8.5	12	8.1	10
6	11.6	27	10.7	21
8	11.8	54	13.3	40
10	13.0	90	18.8	94
12	15.2	134	19.2	188

At the fingerling stage, the relative growth rate conspicuously decreases, compared with the fry stage. Within the rearing period of 100 days, the body weight of fish is double 9-10 times. On an average, it doubles every 10 days, which is 5-6 times less than that at the fry stage. However, the absolute increase in weight is remarkable. (Table 2)

**Table 2.** Growth Rate of Silver carp, Bighead and Grass carp Fingerlings Unit: mm & g

Species	Silver carp				Bighead				Grass carp				
	Age (day)	Total body length	Body weight	Average daily increment		Total body length	Body weight	Average daily increment		Total body length	Body weight	Average daily increment	
				Body length	Body weight			Body length	Body weight			Body length	Body weight
20	47	1.08	3.1	1.4	435	0.9	5.0	5.16					
27									57	1.48	3.4	3.8	
60	173	55.3	2.4	6.78	242	207.5	2.3	7.1					
74									216	157	2.6	8.4	
120	318	420			376	633							
134									372	661			

In accordance with the observation during the cultivation, the fry of four species collected from rivers and polycultured in a manured pond have different growth rates. After being stocked for 1--4 days, the growth of Grass carp is the fastest; Silver carp and Bighead the second. However, after the 8th day of rearing, Silver carp always come in first; Bighead the second; Grass carp the third and Black carp always the last. This remains until the fry reach to summer fingerlings. Apart from heredity, the growth rate of cultivated fish is closely related to the ecological conditions such as nutrition, stocking density, water quality and temperature, etc.

### 3. Distribution and environmental requirements

Fry are more or less evenly distributed in the pond shortly after stocking. When fry reach a body length of about 1.5 cm, their distribution follows the change of their feeding habits. Grass carp and Black carp start to move to the middle and bottom layers of water body and most of them live in the shallow places around pond dikes where there are more macro-zooplankton and benthos; whereas Silver carp and Bighead gradually leave pond banks and move to the central area and stay in the upper and middle layers of water body. Fry and fingerlings have a much higher metabolic rate, particularly at the fry stage. For example, the oxygen consumption rate and energy demand of Silver carp fry is 5-10 times as much as that of summer fingerlings and it is even much higher than that of two-year-old fingerlings. The status of other species is similar to the above; therefore, high dissolved oxygen and abundant food supply should be ensured for rearing fry and fingerlings. The

optimum pH value in nurturing ponds is around 7.5-9. Fry can tolerate salinity of 4-5%. Its growth however, is retarded when the salinity reaches 3%.

## **DIGESTION IN TELEOST FISHES**

### **Definition of the Gut and its Subdivisions**

The gut is a tubular structure beginning at the mouth and ending at the anus. It is commonly divided into four parts. The most anterior part, the head gut, is most often considered in terms of its two components, the oral (buccal) and gill (branchial, pharyngeal) cavities. The foregut begins at the posterior edge of the gills and includes the oesophagus, the stomach, and the pylorus. In fish, such as the cyprinus, which lack both a stomach and pylorus, the foregut consists of the oesophagus and an intestine anterior to the opening of the bile duct. This posterior demarcation is arbitrary and primarily for convenience during gross dissection and may have little relation to the functional aspects. The midgut includes the intestine posterior to the pylorus, often with no distinct demarcation posteriorly between it and the hindgut. The midgut often includes a variable number of pyloric caecae (pyloric appendages) near the pylorus, although pyloric caecae are always absent in fishes which lack stomachs. The midgut is always the longest portion of the gut and may be coiled into complicated loops (often characteristic for each species) when longer than the visceral cavity. In some fish, the beginning of the hindgut is marked by an increase in diameter of the gut. The posterior end of the hindgut is the anus. Only rarely is there a hindgut caecum in fish comparable to that found in mammals. A cloaca (a chamber common to anal and urogenital openings and formed from infolded body wall) never occurs in teleost fish, except the Dipnoi, although it is universal in sharks and rays.

### **Evolution and Ontogeny of the Digestive Tract**

The gut of protochordates consists of a simple, straight tube through which food is propelled by ciliary action. An early elaboration of the gut is seen in lampreys where an infolding (typhlosole) of the gut wall presumably increases the absorptive area of the gut. A similar, but spiral, infolding of the hindgut occurs in sharks, rays, and the coelocanth (*Latimeria*) in the form of the spiral valve (spiral intestine). The gut wall in lampreys also contains diagonal muscle fibres, although true peristalsis (travelling wave of contraction) is thought not to occur. Teleost fish have a gut which is typical of the higher vertebrates in many respects, although the midgut villi (absorptive papilli) of mammals are absent in fish.

The gut forms very early during embryological development (ontogeny) and shows some of the same stages of development as in the evolution of the vertebrate gut, some larval fish having portions of their gut which are ciliated, for example. The general character and even the length of the gut may change during development. The gut appears to shorten, for example, in fish in which the larval stage is herbivorous and the adult stage is carnivorous. In other fish the gut length remains relatively constant in proportion to body size throughout life.

### **Generalizations**

A number of generalizations about the gut of fishes have been attempted, many of them extrapolated from terrestrial vertebrates. The commonest of these, the observation that herbivores have longer guts than carnivores, appears only partially true in fish. While this may be true in limited groups of fish, it is not universal in teleosts as a whole. Gut lengths have been listed as 0.2-2.5, 0.6-8.0 and 0.8-15.0 times body length in carnivores, omnivores, and herbivores, respectively. Thus, the longest guts are found in herbivores, but not all herbivores have long guts; i.e., the gut lengths of some herbivores are shorter than those of some carnivores. Part of the explanation lies in the fact that many fish eat a variety of food, sometimes ingested with considerable indigestible material (e.g. mud) which often influences gut length. The size of the food particles - from submicroscopic plankton to whole fish - may also influence gut configuration.

One generalization so far appears to have no exception. In fishes having no stomachs, no acid phase of digestion occurs, even when the midgut develops stomach-like pouches anteriorly. Although gut tissues exhibit great versatility, the midgut appears unable (or does not need) to duplicate the stomach functions.

In general, most studies relating food habits to gut morphology show considerable relationship between the two. However, the gut also retains considerable reserve ability to respond to new foods, new environments, and new opportunities. This versatility has been demonstrated in a number of cases in which a single genus has adapted to new niches and evolved whole new modes of feeding and digestion to utilize otherwise unexploited food resources and done so over rather short evolutionary periods of time.

At the same time, there are usually severe constraints on adaptations to new food. As long as swimming continues to be important to a fish's lifestyle, any major change in body shape, such as a bulging visceral mass resulting from enlarging the stomach or lengthening the midgut, must extract a penalty in terms of increased effort needed for swimming. Feeding mechanisms must not interfere with the respiratory functions of the gills and *vice versa*. All in all, "packaged" so that any major change in the digestive system would call for major compromises in many other systems. Perhaps the best generalization is that teleost fish maintain an intimate relationship between the form and function of their gut and their food resource. In the final analysis, all of the other life processes continue to function only when sufficient materials and energy are obtained and assimilated via the gut.

## **Anatomy and General Physiology of the Gut**

### ***Functional Anatomy of the Gut***

The mouth exhibits a variety of fascinating adaptations for capturing, holding and sorting food, ratcheting it into the oesophagus and otherwise manipulating it prior to entry into the stomach. Only two which have possible relevance to digestion will be discussed.

In milkfish (*Chanos*), the gill cavity contains epibranchial (suprabranchia) organs dorsally on each side, consisting either of simple blind sacs or elaborate, spirally-coiled ducts. The organs occur in several relatively unrelated families of lower teleosts and apparently relate to the kind of food eaten. Those fish with simple ducts all eat macro-plankton and those with the larger ducts microplankton. Although their function is unknown, concentrating the plankton has been suggested as a possibility.

The common carp provides an excellent example of non-mandibular teeth being used as the primary chewing apparatus. Pharyngeal teeth occur in the most fully developed forms of the Cyprinidae and Cobitidae, although many other groups also show some degree of abrading or triturating ability with some part of the gill bars. In carp, the lower ends of the gill bars have a well developed musculature which operates two sets of interdigitating teeth so as to grind plants into small pieces before swallowing them. The grinding presumably increases the rather small proportion of plant cells which can otherwise be successfully attached by digestive enzymes.

Many fish which chew their food have some ability to secrete mucus at the same time and place. This would have some apparent benefit when ingesting abrasive food. Although one might be tempted to equate such secretions with saliva, enzyme activity in the mucus does not appear to have been demonstrated, so the mucus is only partly comparable to saliva.

The oesophagus, in most cases, is a short, broad, muscular passageway between the mouth and the stomach. Taste buds are usually present along with additional mucus cells. Freshwater fishes are reputed to have longer (stronger?) oesophageal muscles than marine fish, presumably because of the osmoregulatory advantage to be gained by squeezing out the greatest possible amount of water

from their food (i.e., marine fish would be drinking seawater in addition to that ingested with their food and freshwater fish would have to excrete any excess water).

The oesophagus of eels (*Anguilla*) is an exception to this general pattern. It is relatively long, narrow, and serves during seawater residence to dilute ingested seawater before it reaches the stomach. A possible conflict between the osmoregulatory and digestive roles of the gut in marine fish in general will be discussed later (Section 3.5).

Fish stomachs may be classified into four general configurations. These include (a) a straight stomach with an enlarged lumen, as in *Esox*, (b) a U-shaped stomach with enlarged lumen as in *Salmo*, *Coregonus*, *Clupea*, (c) a stomach shaped like a Y on its side, i.e., the stem of the Y forms a caudally-directed caecum, as in *Alosa*, *Anguilla*, the true cods, and ocean perch, and (d) the absence of a stomach as in cyprinids, gobiids, cyprinodonts gobies, blennies, scarids and many others, some families of which only one genus lacks a stomach.

The particular advantage of any configuration seems to rest primarily with the stomach having a shape convenient for containing food in the shape in which it is ingested. Fish which eat mud or other small particles more or less continuously have need for only a small stomach, if any at all. The Y-shaped stomach, at the other extreme, seems particularly suited for holding large prey and can readily stretch posteriorly as needed with little disturbance to the attachments of mesenteries or other organs. Regardless of configuration, all stomachs probably function similarly by producing hydrochloric acid and the enzyme, pepsin.

The transport of food from the stomach into the midgut is controlled by a muscular sphincter, the pylorus. The control of the pylorus has not been demonstrated in fish, but the best guess at this time is that it resembles that in higher vertebrates. The pylorus is developed to various degrees in different species for unknown reasons, in some species even being absent. In the latter case, the nearby muscles of the stomach wall take over this function, which may also include a grinding function by the roughened internal lining. In fish which lack a stomach, the pylorus is absent and the oesophageal sphincter serves to prevent regress of food from the intestine, i.e., in fish lacking a stomach and pylorus, the midgut attaches directly to the oesophagus.

The digestive processes of the midgut have not been studied extensively, except histo-chemically (see Section 4 for details on enzymes), but so far as known resemble the higher vertebrates. The midgut is mildly alkaline and contains enzymes from the pancreas and the intestinal wall, as well as bile from the liver. These enzymes attack all three classes of foods - proteins, lipids, and carbohydrates - although predators such as salmonids may be largely deficient in carbohydrases. The pyloric caecae attached to the anterior part of the midgut have attracted considerable attention because of their elaborate anatomy and their taxonomic significance. Histological examination has proved them to have the same structure and enzyme content as the upper midgut. Another suggestion was that pyloric caecae might contain bacteria which produce B-vitamins as in the rodent caecum. When tested, this hypothesis had no factual basis either. Pyloric caecae apparently represent a way to increase the surface area of the midgut and nothing more. This still leaves an interesting question of how food is moved into and out of the blind sacs which are often rather lone and slim: e.g., in salmonids.

The demarcation between midgut and hindgut is often minimal in terms of gross anatomy, but more readily differentiated histologically - most secretory cells are lacking in the hindgut except for mucus cells. The blood supply to the hindgut is usually comparable to that in the posterior midgut, so presumably absorption is continuing similarly as in the midgut. Formation of faeces and other hindgut functions appear to have been studied minimally, except histologically.

### ***Peristalsis and its Control***

Peristalsis consists of a travelling wave of contraction of the circular and longitudinal layers of muscle in the gut wall such that material inside the gut is moved along. The pharmacology of this

system has been investigated in isolated trout intestine demonstrating that an intrinsic nerve network exists to control peristalsis; i.e., cholinergic drugs stimulated and adrenergic drugs inhibited peristaltic movements. The oesophagus and stomach are also innervated extrinsically by branches of the vagal (cranial X) nerve. No studies appear to have been made so far concerning details of food transport through the teleost gut except for measurements of gastric evacuation time and total food passage time, although gut stasis has been hypothesized to occur in the Pacific salmon, as in domestic animals.

### ***Gastric Evacuation Time and Related Studies***

Many studies have been performed relating to developing an optimum feeding schedule, mostly for salmonids, but also including a number of other cultured fish. Variables considered with feeding rate and gastric evacuation time included temperature, season, activity, body size, gut capacity, satiety, and metabolic rate. A relatively consistent finding has been that gastric emptying rate declines more or less exponentially (sometimes linearly) with time. Larger meals first are often, but not always, digested at a faster rate than small meals and the amount of pepsin and acid produced was somewhat proportional to the degree of distension of the stomach. Stomach mobility often increases with the degree of stomach distension also. The appetite, digestion rate, and amount of secretions produced all decreased with decreased temperature, but the secretions also decreased if tested at temperatures in excess of the acclimation temperature. Appetite, i.e., the amount of food eaten voluntarily at one time, appears to be the inverse of stomach fullness, although this does not explain the entire appetite phenomenon. Appetite continues to increase for a number of days after the stomach is empty, indicating that additional metabolic or neural mechanisms are operating. Data on gastric emptying time, digestion rate, and temperature for sockeye salmon have been shown to reflect the underlying phenomenon. Direct comparison of data on digestion among different workers is difficult, because of differences in species, food and methods used.

The total time for passage of food through the gut until the non-digestible portions of a meal are voided as faeces has not commonly been measured. Gastric emptying time and total passage time in skipjack tuna at 23-26 C was about 12 hours with the intestine being maximally filled about five hours after eating and empty after about 14 hours. Defaecation often occurred 2-3 hours after a meal, presumably being material from a previous meal. After a single meal, faeces were found 24, 48 and even 96 hours after the meal. Thus, there is considerable variation in food passage time, presumably relating to the digestibility of the food. Magnuson (1969) commented that the passage rates in skipjack tuna were at least twice as fast as known for any other fish.

The obvious importance of food passage time becomes apparent when one wishes to analyze faeces resulting from ingestion of a specific meal. If one waits to feed a test meal until the gut is completely empty, then the digestion processes observed will be typical only of starved fish. If one feeds the test meal as part of a regular feeding programme, then the problem is to mark the food for appropriate faecal analysis. Thus the problem is not as simple as it might appear at first.

## **THE FERTILIZERS FOR FISH POND**

### **Fertilization**

In general it is believed that both phosphorus (P) and nitrogen (N) are required in minimum quantities for optimum primary production in fish ponds. The favorable action of potassium (K) has not been clearly demonstrated. Since the required quantities of these minerals are not always available in ponds, it has become a necessity to add them in order to establish an optimum standing crop of zooplankton. This can be achieved by adding minerals either directly (chemical fertilizers) or indirectly (organic fertilizers).

Fertilization means to supply phytoplankton with nutrients for photosynthesis and to promote the growth of phytoplankton, by which zooplankton and other aquatic animals are fed on for their

growth and propagation. Fish feed on plankton and other hydro bios. Pond fertilization lies in cultivation of various food organisms and their propagation in large quantities in fish ponds to provide fish with abundant natural feeds, by which they can grow faster. The yield of fish pond may be raised thereby.

Among the fish food organisms in ponds, there are a series of interrelations between the predator and the prey. The biological term is “food chain”. Fish is the last link of the food chain of hydro bios in ponds.

- e.g. phytoplankton→Silver carp
- phytoplankton→zooplankton→Bighead
- aquatic plant→Grass carp
- plankton→benthos→Black carp

Usually, animals could use only 5–20% energy of both animal and plant feeds. Utilization of energy is related to the length of food chain. The shorter the food chain is, the higher the rate of energy transfer will be, in other words, the higher the utilization rate of energy transfer is, the higher the fish production will be.

The hydro bios in ponds are in a constant progress of growth and death. The dead bodies of organisms will turn from complex organic materials into simple inorganic materials through decomposition by bacteria, and then dissolve in water, which can again be utilized by phytoplankton to produce new individuals. Hence, the materials in ponds are in a constant state of circulation mainly through the food relationship between living organisms. This kind of circulation is called pond material circulation.

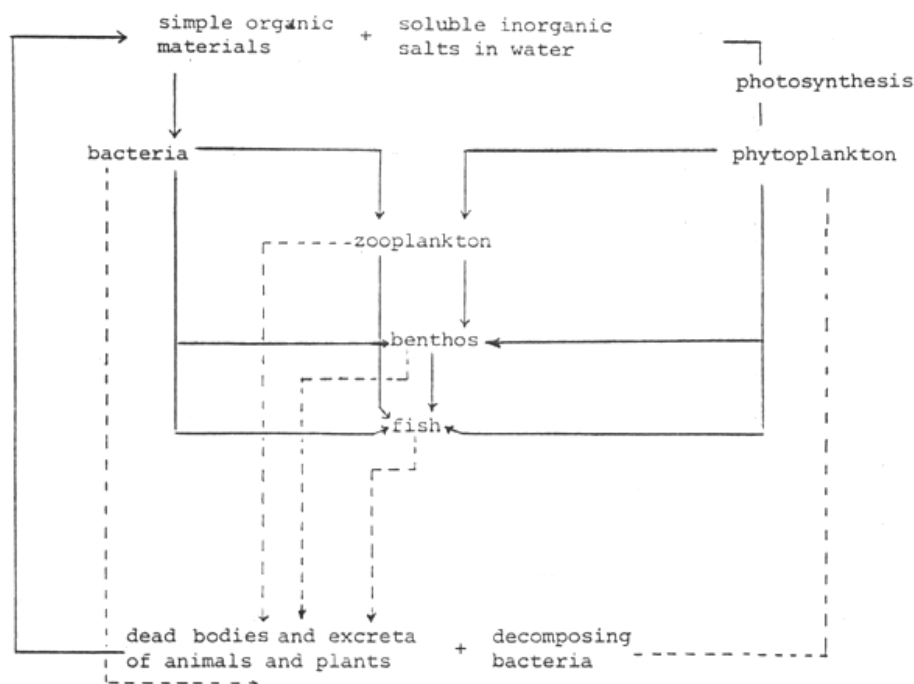

Fig 1 A diagram of material circulation in ponds

The process of pond material circulation is just that of the production of fish and their food organisms in ponds. The circulation originates from the soluble minerals in water. Under certain conditions of light and heat, the propagation of phytoplankton depends upon the amount of nutrients in water. In turn, the production of all food organisms depends upon the proliferation of phytoplankton. Fertilization is just to enhance the quantity of nutrients and to nurture food organisms in ponds so as to create favorable conditions for raising fish yield.

## Chemical fertilizers

In general the mineral composition of chemical fertilizers is expressed either as a percentage of equivalent N, P<sub>2</sub>O<sub>5</sub> or K<sub>2</sub>O. In practice, the main fertilizers used are: super phosphate (containing about 20% P<sub>2</sub>O<sub>5</sub>), triple super phosphate (containing about 45% P<sub>2</sub>O<sub>5</sub>), urea (containing about 45% N) and NPK 15:15:15 (15% N, 15% P<sub>2</sub>O<sub>5</sub>, 15% K<sub>2</sub>O).

### (1) Kinds of inorganic manures and methods of application

Inorganic manures mean chemical fertilizers. According to the composition, the chemical fertilizers can be divided into three groups, that is, nitrogenous, phosphoric and potash fertilizers. The advantages of inorganic fertilizers are exact constituents, fast effect, and slight pollution, no consumption of dissolved oxygen in water, small application amount and convenient operation. However, when chemical fertilizers are applied in ponds, the first link of the food chain in ponds is principally phytoplankton which, if taken as food for zooplankton, is nutritionally not as nice as bacteria. Therefore, the zooplankton amount in ponds applied with inorganic manure often lags far behind that in ponds applied with organic manure. Moreover, in most ponds applied with chemical fertilizers, the predominant species of phytoplankton are Chlorophyta, which is nutritionally worse than the predominant species in ponds applied with organic manure, such as Chrysophyceae, Bacillatiophyceae and Cryptophyceae. In addition, the manure effect is rather short and it is difficult to control the water quality, therefore, the result of the application of chemical fertilizers there is not better than that of the application of organic fertilizers.

#### (i) Nitrogenous fertilizers

- A. Liquid ammonia: Molecular formula, NH<sub>4</sub>OH or NH<sub>3</sub> x H<sub>2</sub>O, with a nitrogen content of 12-16%. It is a water solution of ammonia, which is an important product of small-scaled nitrogenous fertilizer factory with simple synthesizing procedure and low cost. Ammonia is in an unsteady state when in water, easy to volatilize, so it could almost lose its effect through the volatilization if it is exposed to the air for a long period of time.
- B. Ammonium sulphate: Molecular formula, (NH<sub>4</sub>)<sub>2</sub>SO<sub>4</sub>, with a nitrogen content of 20-21%. It is produced from the liquid ammonia directly neutralized with diluted sulphuric acid. It is white crystals when pure, apt to dissolve in water. 100 kg of water can dissolve 75 kg of ammonium sulphate. With a little absorption of moisture, it is convenient to preserve and apply.
- C. Urea: Molecular formula, Co(NH<sub>2</sub>)<sub>2</sub>, with a nitrogen content of 44-46%. Ammonia and carbon dioxide are interacted and synthesized into urea under high heat & pressure. It is white crystals with a strong absorption of moisture. After dissolution in water, urea does not turn out ions and is unable to be absorbed directly by plants. It can be utilized by plants only after it is decomposed by urease excreted by urea-decomposing bacteria and transformed into ammonium carbonate. The conversion rate of urea is related with the temperature. It can be totally transformed into ammonium carbonate in 4-5 days at 20°C and in 2 days at 30°C.

#### (ii) Phosphoric fertilizers

Calcium superphosphate: Main contents, Ca(H<sub>2</sub>PO<sub>4</sub>)<sub>2</sub> H<sub>2</sub>O with 12-18% of P<sub>2</sub>O<sub>5</sub>; subsidiary-contents, CaSO<sub>4</sub>. 2H<sub>2</sub>O, about 50%. Usually, it is white powder. It is corrosive, and is apt to absorb moisture, smelling acidic since there is some free acid in the products.

### (2) Methods of the application of inorganic manure

Nitrogen is one of the essential nutritional elements in a plant. It is also the principal content in protein, and can accelerate the formation of plant chlorophyll and strengthen photosynthesis. For this reason, the nitrogen content is one of the decisive factors of phytoplankton production.



Nitrogen is always short in pond water, so the application of nitrogenous fertilizer may achieve better results.

Nitrogenous fertilizer is generally better to be used as an additive because of its quick-effectiveness, and the nitrogenous fertilizer with ammonium content must not be mixed with strong-alkaline materials lest it should convert into gas and lose effect through volatilization. In the utilization of nitrogenous fertilizer in ammonium form, due attention must be paid to toxicity of ammonia. Either ammonium or liquid ammonia will become ionic  $(\text{NH}_4)^+$  and nonionic  $(\text{NH}_3)$  once they are placed in water. This phenomenon may be expressed in the following formula:

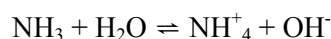

In an acidic state, the balance inclines to the right side with the concentration of ammonium ions enhancing; and in an alkaline state,  $\text{NH}_3$  concentration will raise high. As water temperature comes up to  $25^\circ\text{C}$  with pH6, the concentration of  $\text{NH}_3$  holds 0.05% in total nitrogen; pH7, 0.49%; pH8, 4.7%; pH9, 32.9%.

$\text{NH}_3$  is toxic to fish. It poisons juvenile rainbow trout at 0.3-0.4 mg/L. The Chinese carp have a higher toleration to ammonia anyhow; ammonia inhibits the growth of fish. The mortal concentration is beyond 13 mg/L. The highest concentration permitted in the water body for fish farming is 0.1 mg/L. For this reason, the amount must be strictly controlled in one application. What is more, caution must be given to pH value to avoid being applied in strong alkaline water (e.g. just after pond clearing with lime) since liquid ammonia is alkaline itself. Besides, the amount of nonionic ammonia is rising with the increasing of water temperature, so special care is needed when nitrogenous fertilizer in ammonia form is used in hot summer and autumn.

The application amount of nitrogenous fertilizer depends upon the nitrogen content of the fertilizer applied. In a pond with the area of  $1000 \text{ m}^2$  and the water depth of about 1.5 m, 2.5-3 kg may be given as base manure. From then on, the additive of the fertilizer is applied 3-4 times monthly with  $0.75 \text{ kg}/1000 \text{ m}^2$  each time. For example, if nitrogen content in ammonium sulphate is about 20% and 2 kg are given to  $1000 \text{ m}^2$  as base manure, the amount of ammonium sulphate needed is 10 kg.

$$2 \text{ kg} \times 100/20 = 10 \text{ kg}$$

Applying method: make a solution of it and spread it near the dikes. In case of liquid ammonia, put the container with ammonia under water and then open the lid so as to let liquid ammonia diffuse out slowly. By this way, the volatilization can be avoided during the operation on the bank.

Most waters are lacking phosphorus, so it is important to apply phosphoric fertilizer, which can accelerate the reproduction of a zotobacteria, and enrich nitrogenous fertilizer in water.

The application amount of phosphoric fertilizer is calculated in accordance with the content of phosphoric acid applied. If  $0.75\text{-}1.5 \text{ kg}/1000 \text{ m}^2$  is used as base manure the annual amount might be about 5 kg. The method of calculation and application is the same as above.

Potassium is also one of the principal nutritive elements for plants, but usually it is plentiful in water. There is no particular need to apply potash fertilizer in aquaculture.

### **Organic fertilizers**

The most commonly used organic fertilizers are poultry manure, duck manure, pig dung, sheep dung and cow dung. In general, the fertilizing value of manure depends upon the C:N ratio in increasing order from cow and sheep manure followed by a grouping of pig, chicken and duck manure. The quantity of organic and inorganic fertilizers required varies from place to place and from pond to pond. In the catfish nursing ponds were fertilized with dry chicken manure at a rate of  $50 \text{ kg}/100 \text{ m}^2$  one week prior to stocking. This resulted in a good phytoplankton bloom, the

pond water containing about 1.5-2 ml of plankton per 100 litre of water and having a secchi disk reading of 20-25 cm

### (1) Kinds of organic manures and methods of application

Organic manures mainly refer to excrements of farm animals. It is a general term of manures containing organic matter. Nowadays, manures applied in fish ponds are mainly organic manures. In production, the following are often used, faeces and urine of livestock and poultry, night soil, green manure, compost and silkworm faeces etc. Only through decomposition by microorganisms, organic manures may be converted to nutrients, which plants can absorb, and then, organic manures are full of nutritional elements with long effects.

#### (i) Faeces and urine of livestock and poultry

A. *Pig manure* Composition and characteristics: pig manure includes much organic matter and other nutritional elements like nitrogen, phosphorus and potassium and is a kind of fine, complete manure. Pig faeces are delicate, containing more nitrogen with a c/n proportion of 14/1, smaller than that of other livestock faeces, so they are easy to rot. The major portion in pig urine is nitrogen in urea form. It is easy to decompose. See Table 3 about pig faeces elements.

**Table 3.** Nutritional elements in pig manure

Elements Kind	Moisture	organic matter	N	P <sub>2</sub> O <sub>5</sub>	K <sub>2</sub> O
Faeces	85	15	0.6	0.5	0.4
Urine	97	2.5	0.4	0.1	0.7

Excretory amount: The excretory amount of pig is greatly associated with its body weight and food intake. From the measurements, a pig of 50 kg in body weight discharges about 10 kg per day, about 20% of body weight. A pig offers 1000 kg of faeces, 1200 kg of urine in the culturing period of 8 months from pigging to the adult Pig's daily excretory amount is less than cow's or horse's. But, pigs have the merits of faster growth, shorter fattening period, and suitability for pen culture, whereas the scale of pig rising is much larger; so it is more beneficial to collect their manure.

B. *Cattle manure* Composition and characteristics: The elements are similar to those in pig manure, but cattle are ruminants and the food-stuffs are repeatedly masticated, so that the excrement is delicate. There is less nitrogen in the composition of cattle manure. The C/N proportion is 25:1. The cattle urine contains more nitrogenous element in hippuric acid form, (C<sub>6</sub>H<sub>5</sub>CONHCH<sub>2</sub>COOH), so that cattle excreta are slow to decompose.

**Table 4.** Nutritional elements in cattle excrement (%)

element Item	Moisture	organic matter	nitrogen	P <sub>2</sub> O <sub>5</sub>	K <sub>2</sub> O
Faeces	85	14	0.3	0.2	0.1
Urine	93	2.3	1.0	0.1	1.4

Excretory amount: The average daily excreta is 25 kg each, in which the ratio of faeces and urine is about 3:2. The yearly total amount of excrement for each is 9000 kg.

*C. Poultry manures* Composition and characteristics: Poultry manures include faeces of chicken, duck and geese, which contain much more nutrients. For the nutritional elements in poultry manures.

**Table 5.** Average amount of nutrients in poultry manures

element Kind	Moisture	organic matter	nitrogen	P <sub>2</sub> O <sub>5</sub>	K <sub>2</sub> O
chicken faeces	50.5	25.5	1.63	1.54	0.85
duck faeces	56.6	26.2	1.10	1.40	0.62
goose faeces	75	23.4	0.55	0.50	0.95

Poultry manures are easy to rot and the nitrogen in poultry manures is chiefly in uric acid form, which could not be absorbed directly by plants, accordingly, poultry manures are better to be used after fermentation.

Excretory amount: As for each fowl, the yearly amount of excrement is not large, chicken 5-5.7 kg; duck 7.5-10 kg and goose 12.5-15 kg. Though the excretory amount of each is small, the quantity of poultry culture is often great; therefore, every fowl faece is one of manure sources. The total amount is quite a lot.

**(ii) Night soil**

Composition and characteristics: The composition of night soil is greatly dependent on the food, with a larger quantity of nitrogen, of which 70-80% is in urea form. It is apt to be absorbed with good effect. C/N proportion of human excreta is three to one. They are easy to ferment. The nutritional elements in human excreta are listed in Table 6

**Table 6.** Nutritional elements in human excreta (% in wet weight)

Element Kind	organic material	N	P <sub>2</sub> O <sub>5</sub>	K <sub>2</sub> O
Human excreta	5-10	0.5-0.8	0.2-0.4	0.2-0.3
Human faeces	20	1.0	0.5	0.37
Human urine	3	0.5	0.13	0.19

Excretory amount: Night soil is a popularly-applied manure. From the measurements, a yearly amount from an adult is shown in Table 7

**Table 7.** Yearly amount of an adult's excreta (kg)

Item Kind	Excretory amount	Equivalent		
		(NH <sub>4</sub> ) <sub>2</sub> SO <sub>4</sub>	calcium superphosphate	potassium sulphate
Human faeces	90	4.5	2.25	0.7
Human urine	700	17.5	4.55	2.8
total	790	22	6.8	3.5

Night soil, used as manure has to be fermented before application. It can be rotten under anaerobic conditions in storage for 2-4 weeks. The decomposition of human waste produces ammonia. Under airtight conditions, after reaching to a certain concentration, ammonia can sterilize human waste. 1-2% quicklime or 0.1-0.2% formalin can also kill harmful insects and bacteria in night soil.

### (iii) Silkworm dregs

Composition and characteristics : Silkworm dregs are composed of the faeces and sloughs of silkworm as well as mulberry residues. Silkworm dregs are full of organic matter. Dried ones contain 87% organic materials and 3% nitrogen. They are also good feeds for fish. 8 kg of silkworm dregs can produce 1 kg of fish.

### (iv) Green manures

All wild grasses and cultivated plants, if used as manure, are called green manures, which are apt to rot and decompose, providing ideal environments for bacteria propagation, so they are good for application in ponds. A few common green manures are listed in Table 8

**Table 8.** Nutritional elements in green manures (% wet weight)

Plant	N	P <sub>2</sub> O <sub>5</sub>	K <sub>2</sub> O
stems and leaves of broad bean <u>Vicia faba</u>	0.55	0.12	0.45
Rape <u>Brassica napus</u>	0.43	0.26	0.44
Alfalfa <u>Medicago falcate</u>	0.54	0.14	0.40
wild grass	0.54	0.15	0.46
barnyard grass <u>Echinochloa crusgalli</u>	0.35	0.05	0.28
water peanut <u>Alternanthera philoxeroides</u>	0.20	0.09	0.57
water hyacinth <u>Eichhornia crassipes</u>	0.24	0.07	0.11
water lettuce <u>Pistia stratiotes</u>	0.22	0.06	0.10

### (v) Compost

Mixed compost is made of green manures and animal wastes. The mixture of several manures may make the ingredients of manure all the more suitable to the reproduction of plankton. The ratio of the constituents of manures depends upon the local sources of manures. From experiments, the following proportion of the ingredients of compost is suitable for plankton reproduction.

A. Green grass 8:cattle faeces 8: human excreta 1:lime 0.17.

B. green grass 1:cattle faeces 1:lime 0.02

There are two methods to make compost, that is, heaping and soaking. Heaping method: The manure heap is to be made under aerobic conditions. Spread one layer of green grass, then sprinkle some lime on it. Then add another layer of faeces manure and do it again, layer by layer up to 1.5-2 m. At last, cover the heap with 5-6 cm thick of mud. The ingredients of the compost will rot and decompose. After 3-4 weeks the compost can be used.

Soaking method: dig a pit near fish ponds, put in green grass, lime and faeces one layer after another and then add some water to soak all manures with no leakage at all. The use of lime is to neutralize the organic acids turned out in the process of rotting & decomposition of the compost so that they could not attenuate the activities of microorganisms, whereas they could promote the decomposition of organic materials. The compost can be taken out for use after 10-20 day's fermentation at a temperature of 20°-30°C.

## (2) Methods of the application of organic manures

### (i) Application of Dacao:

Dacao is habitually used to fertilize pond water. The so-called Dacao means several composite plants. In reality the grass is not limited to composite plants; some gramineous plants and leguminous plants are sometimes used as well. In application, Dacao is just heaped at a corner of pond and is turned once every other day or every two days. The rotten part will go spreading in water and at last, the roots and stems which are hard to rot, will be dredged up out of ponds. The decomposition of green manure in water consumes a great amount of oxygen. In light of

experiments, if 1500 kg of grasses are applied in a pond of 1000 m<sup>2</sup> with a water depth of one meter, all fish may die of lacking oxygen as the pond is in a state of no oxygen from the second day to the sixth day. The peak of oxygen consumption is on the second and third day. And it will be reducing later on. It is appropriate to apply green manures frequently in a small amount, or to pour fresh water into ponds or adopt aerators, in order to guarantee plenty of oxygen in pond water.

**(ii) Application of night soil.**

Night soil is applied in fish ponds and the application amount varies with fish sizes. Before application, one portion of night soil is diluted with double portions of water. The dilution is then sprayed along the pond dikes. It is added once a day and the added amount is dependent on the fertility of water.

**(iii) Application of livestock manures**

The application of livestock manure as base manure is similar to that of green manures: heap the manures at a corner of pond or put them in small heaps in shallow water with a sunny exposure so as to make them decompose and spread gradually in water. If the manure is used as an additive, it is added in small heaps every 7-10 days.

**(iv) Application of mixed compost**

After fermentation, the compost is taken out, and given a flush. The liquid is collected and the residues are removed away. Spray the liquid evenly into ponds. In case the area of the pond is rather big, you may load the needed amount of manure on a boat, flush it with pond water in batches and then spray the liquid evenly in ponds. The manure dregs can be used to fertilize crops. For small ponds, there is no need to use a boat. The liquid is spread round the dikes. Another method is to put one side of the compost to the other in the pit and expose the liquid and then the manure liquid can be ladled out and spread into ponds according to the required amount.

The nutrients of the compost can be quickly absorbed by phytoplankton once the compost is applied in ponds. It consumes less dissolved oxygen in ponds since the organic materials are already decomposed after full fermentation.

**(3) Effects of manure application on food organisms**

First of all, the application of organic manure causes the propagation of bacteria in large quantities. On one hand, the bacteria decompose organic materials, mineralizing them into nutritional inorganic materials, which can be utilized by phytoplankton; on the other hand, they themselves take part of the nutrients as their own structural materials, reproducing a large population of bacteria.

After organic manure being applied, the organic detritus in water is increasing in quantity. The organic detritus carries dense bacteria on its surface; which are the important food for lower aquatic animals and filtering fish.

After manuring, the predominant species of plankton at their initial appearance in water depend closely on the properties of the manure. If organic manure is applied, those that are fond of organic materials will show the first population bloom phytoplankton: Ochromonas spp. Cryptomonas; zooplankton: Urotrichia spp. etc. For inorganic manure, the predominant species which will be seen at first are centric diatoms Centrales and Scenedesmus acuminatus. There is a close relationship between the amount of manure applied and the plankton community. Huge amount of manure will lead to the presence of some species of green algae Chlorophyta and blue algae Cyanophyta while small amount of manure will lead to the presence of Navicula rostellata and Cyclotella stelligera etc.



After each application, the nutrient content in the water increases, resulting in a planktonic peak. Phytoplankton which is easily digested by silver carp reach a peak after 4 days, whereas those that are not so easily digested will attain a climax in 5-10 days. Zooplanktons reach a peak in 4-7 days.

Protozoan will be the first zooplankton to reach a peak, followed by rotifers, cladocerans, and finally copepods. Since protozoan multiply by binary fission, by which the population increases very rapidly, it will, therefore, be the first to reach a peak. Rotifers undergo parthenogenesis under normal condition. The eggs produced are not very many, with an average of 10-20 eggs during their life span. Thus, the rotifer population reaches a peak slightly later than the protozoan. Cladocerans also reproduce parthenogenically, but the span between hatching and sexual maturity is longer. So the cladoceran peak appears later than that of the rotifer. The timing of manure application is most important. Ideally, the peak should appear at a time

## FUNDAMENTAL OF FISH NUTRITION

### Significance of food application

In addition to the fertilization in ponds for proliferation of natural food organisms for fish, artificial feeds must be supplemented to meet the demands of various species of fish. Fish feeds are the prime material base of high-density fish culture. Applying artificial feeds in fish pond can raise the per-unit yield by a big margin. Take common carp as an example. The output does not exceed 25--30 kg/mu in extensive culture, whereas in intensive culture the output will be as high as 200--250 kg/mu. The rapid increase of yield comes from the direct effect of artificial feeding, the so-called fish yield of artificial feeding; however, the plankton-eater output is also enhanced. Especially in the system of polyculture in China, the consequence of feeding is more conspicuous. Because the food applied can be directly taken in by the so-called feed-eaters, in turn, the excreta of which can fertilize the pond water, multiplying the natural food for the plankton-eaters. In such a culture system, the yield of these species often occupies  $\frac{1}{3}$  of the total fish output.

### Fish requirements for different nutrients

The nutrients that fish require are the same as the other animals. They can be sorted into five kinds: protein, carbohydrates, fats, vitamin and minerals. The demands of fish for these nourishing elements are the fundamental basis for selection and preparation of fish feeds.

Basis for selection and preparation of fish feeds.

#### (1) Protein

Protein is the basis of all living things. Just as other animals, from food, fish take in protein which's decomposed into amino acid through enzyme in the digestive organs. The amino acid is absorbed internally and synthesized into fish protein for growing mending tissues and maintaining life activities. It is used as energy for fish activities when fats and carbohydrates are not sufficient. One gram of protein can supply 4 kilo calories.

The demand of fish for protein contents in feeds is generally 25---40%. It is higher than the demand of terrestrial animals like chicken or pig or cattle, that is 12---17%. Since fish are cold-blooded animal without need of maintaining body temperature, they require lower energy comparatively. Different fish have different feeding habits, so do their requirements for protein contents in feeds. Carnivorous fish like rainbow trout and eel demand higher protein contents, while herbivorous fish lower.

The nutritional value of food depends not only on the quantity of protein but also on the quality of it, namely, the compositions of amino acids. Amino acid is the elementary unit, of which protein is constructed. The researches have proved that several amino acids are essential to fish growth. Therefore, they must be fully prepared into the feeds. These amino acids are termed essential

amino acids while the other amino acids, which may not exist or may be just a little in feeds, are called dispensable amino acids because they are needed only in small amounts or can be synthesized internally.

The following ten amino acids are essential amino acids to fish: isoleucine, leucine, lysine, methionine, phenylalanine, threonine, tryptophan, valine, arginine, and histidine. These ten must be included in fish feeds so that they can satisfy the nutritional requirements of fish and guarantee the normal development and growth. Besides, the proportion between different essential amino acids in protein must conform to the nutritional requirements of fish, which is dependent on the composition of amino acids in fish protein, so the proportion of all essential amino acids of fish may be referred to the composition of fish body protein. From the above-mentioned factors, we can arrive at a conclusion that the nutritional value of protein is determined mainly by the completeness of the sorts of essential amino acids and the equilibrium of specific value between all essential amino acids to the fish you feed. As for the incomplete and unbalanced protein, we can still raise its nutritional value greatly by way of supplementing those amino acids it lacks.

### *(2) Carbohydrates*

carbohydrates are also called saccharide, in other words, the chief source of energy. Through digestion, they are decomposed into monosaccharide absorbed and utilized by fish body. In the organic body, part of them is decomposed through oxidization into carbon dioxide and water, releasing energy. Applicable heat is 4 kilocalories each gram of carbohydrate; part of them is conveyed into livers and muscles as glycogen to be preserved for the time being and the remaining part may be converted into fats, to be cumulated for life maintenance in case of shortage of food or stoppage of food-taking.

Cellulose is also a kind of carbohydrates, the major component of plant cell wall. Among the cultivated fish, only a few species like Tilapia and milk-fish can digest cellulose at a rather low utilization rate. It is believed that Cyprinids lack the cellulolytic enzyme. In consequence, they are unable to utilize cellulose, and neither are Grass carp, the typical herbivorous fish. An appropriate amount of crude fibers in fish feeds can stimulate the digestive movements of the intestinal tracts so as to promote the digestion and absorption of other nutrients.

### *(3) Fats*

Fats are also a source of energy. Every gram of fats deliver 9 kilocalories of applicable heat. Fats are decomposed in digestive tracts into fatty acid and glycerol which can be absorbed. After absorption, the body fats are synthesized from the excessive fatty acid and glycerol, storing in subcutaneous tissues, muscles, spaces between connective tissues and the abdominal cavity.

Fats are apt to deteriorate through oxidization, bringing about toxic substances like aldehyde and ketone etc, which are detrimental to fish and destroy Vitamin E in fish feeds. If fish take in too much deteriorated fish meal and silkworm pupae, they will suffer from thin-back disease, muscular atrophy, losing weight and higher mortality.

### *(4) Vitamins*

Vitamins are organic trace elements indispensable for fish. There are so many sorts of these substances with various physiological functions; however, all of them are indispensable to keep fish fit with a normal growth.

A number of Vitamins take part in the process of metabolism: e.g. Vitamin B1 of body carbohydrates; Vitamin B6, of proteins; Vitamin C, that of the synthesis of body protein of animal; And Vitamin D, of the normal metabolism of calcium and phosphorus, promoting the formation of skeleton.

As it is, it is not easy to determine the exact amount of various Vitamins required by fish. On the basis of the practical state and the characteristics of the cultivated species in China, fresh feeds are added to make up the deficiency of Vitamins. If pellet feeds are applied in farming Grass carp, green grass may be supplied at intervals so as to replenish the Vitamins the fish lack and the effect is desirable.

#### *(5) Minerals*

Minerals are essential elements of fish body composition. Without minerals, the organic bodies are unable to retain normal physiological functions. Phosphorus and calcium are the important components of skeleton. The deficiency of the two substances will affect the skeleton development with a result of deformity.

The minerals demanded by fish come basically from feeds and part of them directly from environmental water. Fish absorb the calciferous and phosphorous salts and the ions of chlorine and sodium through their gill rakers and skin.

Minerals in diet may enhance the utilization of carbohydrates by fish, accelerate the growth of fish tissues like skeleton and muscles, improve their appetite and speed up the growth of fish body, and therefore, in the preparation of fish feeds, the minerals must be taken into consideration. As a whole, some additives like bone powder and table salt in fish feeds are enough for the pond fish.

### **4. Principle of Feed formulation**

The process of determining the right kind and amounts of ingredients to be mixed together to produce a nutritionally adequate diet for a species is referred to as diet formulation. Data on nutrient requirements and various information on feed ingredients are needs.

The three mathematical methods commonly used in balancing diets are: the square method (or Pearson's square), algebraic method, and the computer method of least-cost formulation.

#### *A. Square method*

This is the simplest method in formulating diets, particularly supplemental, without resorting to trial and error. The method works only when the desired level of nutrient in the diet is between the levels found in the ingredients. It balances the diet with respect to one nutrient at a time.

#### *B. Algebraic method*

The use of algebraic equation solved simultaneously is convenient for more complicated problems such as those involving many ingredients, fixed components and certain dietary restrictions.

#### *C. Computer method of Least-Cost Feed Formulation*

The nutrient requirements, nutrient composition of feedstuffs, digestibility, cost of ingredients, and dietary restriction (maximum or minimum levels of incorporation) are among the information needed in feed formulation with the aid of a computer. Linear programming is a mathematical technique using a computer to check all possible combinations of ingredients that would meet the desired levels of nutrients in the diet being formulated. Theoretically, there can be several solutions to a given problem, but as soon as the cost factor is considered, there will only be one least-cost formulation. The computer output has to be examined in order to produce a more realistic ration. Computer formulations have to be reviewed and revised from time to time as more information on nutrient requirements and digestibility become available or when there are changes in the nutrient composition and price of feedstuffs.



**FOR RURAL DEVELOPMENT**

**Principles of Fish Seed Production**

**SUBJECT PLAN**

<b>Subject</b>	Principles of Fish Seed Production
<b>Date/Time</b>	4 July 2007, 09.00-12.00 hrs
<b>Objectives</b>	After the subject, The participants will be able to: 1. Understand principles of fish reproduction 2. Understand principles of hormone used for induced spawning
<b>Topics</b>	1. Brood stock development including species selection 2. Seed collection 3. Fish Breeding
<b>Detailed Activity</b>	
<b>Time</b>	<b>Sub-activity</b>
<b>4 July 2007</b>	
<b>09.00-09.30</b>	<b>1. Brood stock development including species selection</b> The management of brood stock in captivity is necessary procedure for produce mature brooder.
<b>09.30-10.15</b>	<b>2. Seed collection</b> Egg incubation and Hatchery system
<b>10.30-12.00</b>	<b>3. Fish Breeding</b> Gonadal development and Hormone function. Type of hormone and hormone used.



## PRINCIPLES OF FISH SEED PRODUCTION

*Naruepon Sukumasavin, Ph.D.*  
*Technical Group, Inland Fisheries Research and Development Bureau,*  
*Department of Fisheries, Thailand.*

*Lectured by Choltisak Chawpaknum*

### BACKGROUND

Induced fish breeding has been practised in Thailand since 1933, when the Thai Department of Fisheries successfully induced natural breeding in the common carp. In 1958, the technique of using pituitary hormones to induce spawning in fish was introduced to Thailand. This technique has been used effectively to induce spawning in several fish species: i.e., striped catfish, *Pangasianodon hypophthalmus* (Boonbrahm, 1959), walking catfish, *Clarias macrocephalus* (Tongsanga, 1961) and tawes, *Barbodes gonionotus* (Sidthiimunka, 1962). Recently, the technique of using gonadotropin releasing hormone analogues (GnRHAs), and a dopamine antagonist such as domperidone has been developed for fish species indigenous to Thailand (Sukumasavin and Leelapatra, 1988). This has proven to be very effective. Now, more than 20 species, which could not be effectively induced by pituitary gland extract, have been successfully induced to spawn using the GnRHA and domperidone approach.

### BROODSTOCK MANAGEMENT

Teleosts are poikilothermic animals whose sexual maturity depends on water temperature. Under tropical conditions, most fishes become sexually mature within the first year (Horvath *et al.*, 1984). For example, *Barbodes gonionotus* matures sexually at the age of 8 months, when the length is only 8.5 cm (TL) and the weight 9 g (Paohorm, 1969). Although the fish is mature, the fertility of the eggs is poor. Thus, a low survival rate of the larvae has been reported from female *B. gonionotus* weighing 100 g. Therefore, the appropriate size of this species for breeding purposes is about 200 g (Joragun, 1978). In some tropical freshwater species, sexual maturation takes longer than one year: for example, 2 years in *Morulius chrysophekadion* (Unsrisonong *et al.*, 1990), 3 years in *Osphronemus gouramy* (Pasukdee, personal communication), 4 years in *Probarbus jullieni* (Rodrarung *et al.*, 1990) and more than 10 years in *Pangasianodon gigas* (Sukumasavin, personal observation).

In hatchery operations, large broodstock are difficult to handle and require a longer period for adapting to captive conditions. Horvath *et al.* (1984) have suggested the following guidelines for the management of broodstock in captivity:

1. Select healthy fish with good physical characteristics.
2. Feed them with good quality food of the correct dietary composition.
3. Keep the broodstock at a low stocking density.
4. Identify the sex of the broodstock and keep separately if possible, because mixed stocks are inclined to spawn naturally.
5. Replace unspawned broodstock because the broodstock should not only tolerate but actually respond positively to induce spawning.
6. Keep spent (spawned) fish separately from the other broodstock and feed with protein-rich feed at 2-5% body weight per day, in order to promote recrudescence of eggs and sperms.
7. Produce natural feed by adding fertilizers regularly.
8. Select deep ponds for keeping broodstock and supply with adequate water, in order to ensure favourable water quality and to stimulate gonadal development.
9. Before each spawning season, add some trash fish into the feed, in order to promote gonadal development as well as recovery.
10. Stock new spawners with old spawners, for the replacement of broodstock.

## FISH BREEDING

Fish reproduction is generally initiated by environmental factors (Fig.1 and Fig. 2), for example: temperature, rainfall, water quality, photoperiod, and food quality as well as food availability. The fish receives these signals through the brain and interprets them, in order to determine whether the environmental conditions are suitable for spawning. The message is then sent to the hypothalamus, which produces gonadotropin releasing hormone (GnRH). This is passed to the pituitary gland, which is located underneath the brain. The pituitary gland then produces gonadotropins (GtHs). Both GnRH and GtHs cause tiny incipient gonads to develop, mature and finally release gametes at the end of the process. This is a slow and long process, influenced by environmental temperature. In tropical countries, the process is faster than in temperate areas, where yolk formation slows down or almost stops during the winter season (Harvey and Carolsfeld, 1993).

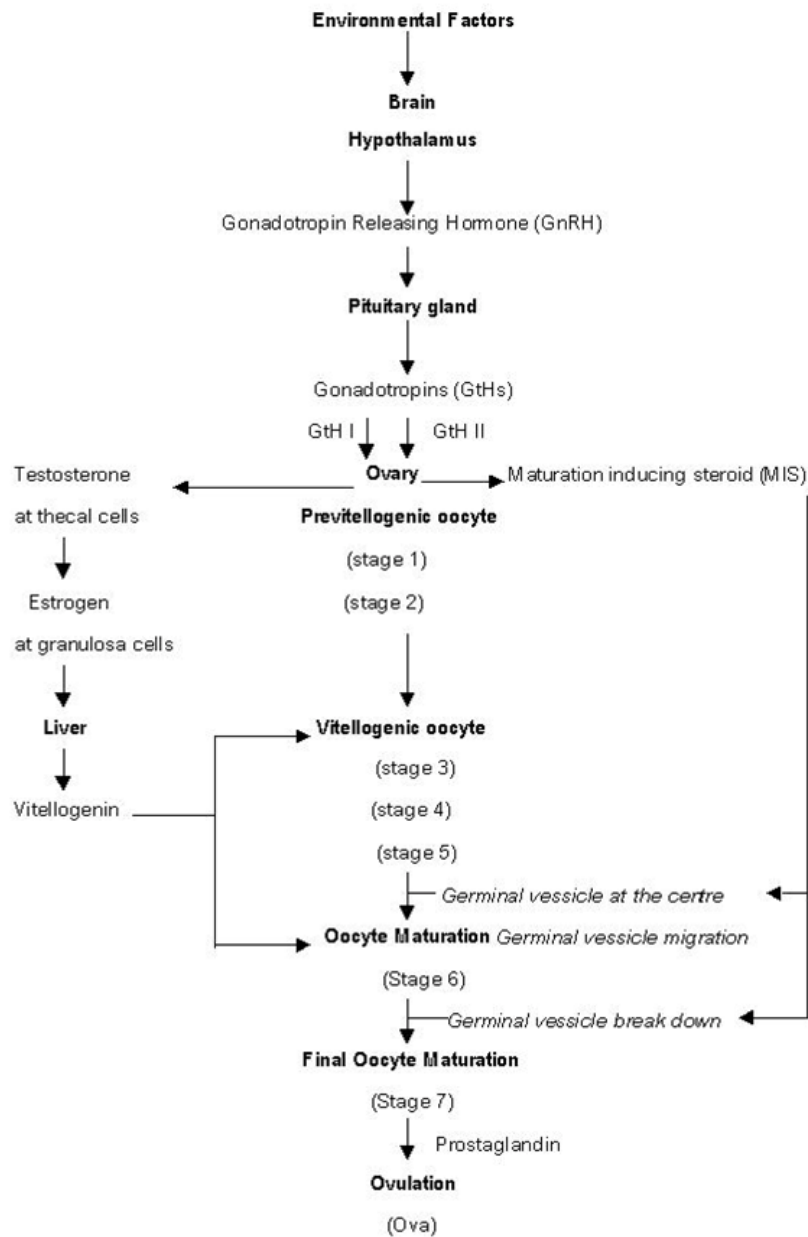

Figure 1: Events in the reproductive endocrine control of maturation and ovulation, amongst female teleosts

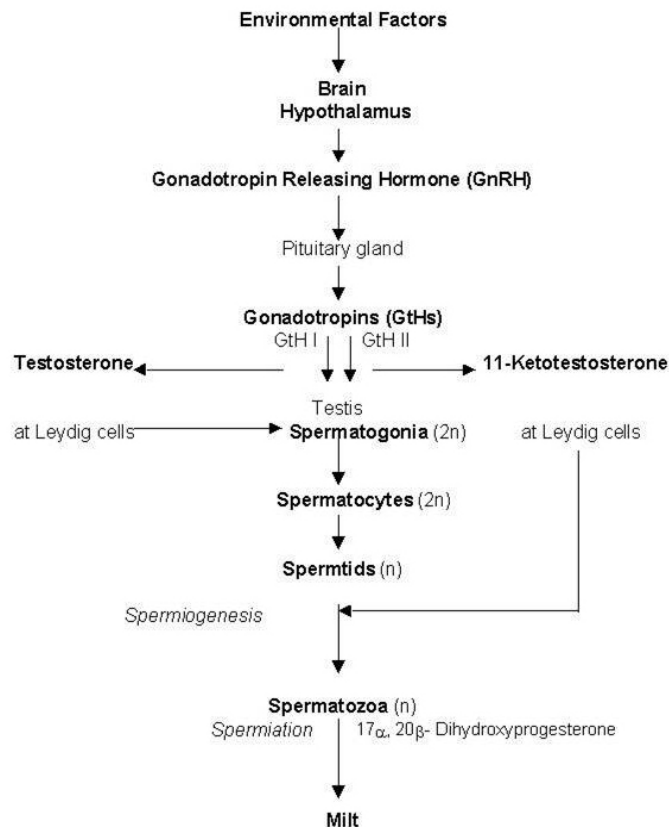

Figure 2: Events in the reproductive endocrine control of maturation and spermiation, among male teleosts

### Female gonadal development

In the female, GtH I stimulates steroidogenesis in the ovary to produce testosterone in the theca cells, where it is then converted to estrogen by the granulosa cells of the oocyte follicle. The estrogen triggers the liver to start producing vitellogenin (yolk protein), which is sent via the blood and deposited in oocytes. The oocytes then develop slowly until mature. At that stage, the concentration of GtH I peaks. The ovary stops producing estrogen and instead starts producing a maturation-inducing steroid (MIS), under the control of GtH II. The MIS stimulates the germinal vesicle of the mature oocyte to migrate to the periphery of the oocyte and then break down at final oocyte maturation. Next, prostaglandin causes ovulation that result in free ova (Fig. 1). This process is called oogenesis and is similar in most teleosts. However, details may vary considerably in different species.

During oogenesis, oocytes are divided into various stages depending on the morphology of the nucleus, cytoplasm and follicle. These stages may be grouped into the previtellogenic, vitellogenic, maturation, and atresia phases. Details of each stage are completely documented in Selman and Wallace (1989).

**Previtellogenic phase:** Oogonia undergo mitotic proliferation and enter the first meiotic division. The nucleus of the oocyte contains only one nucleolus (primary oocyte, stage 1). The primary oocyte is arrested in the ovary until it enters a growth phase (stage 2). The stage 2 oocyte increases in size progressively, surrounded by a layer of granulosa cells. The nucleus has several nucleoli at this stage, which are positioned in the peripheral region of the nucleus. RNA and mRNA of the oocytes are transported from the nucleus into the oocyte cytoplasm. They are called yolk nuclei or Balbiani bodies. The Balbiani bodies, which cause the oocyte cytoplasm to be stained basophilic, are initially located at the nuclear membrane (stage 2a) and subsequently migrate through the

periphery of the cytoplasm (stage 2b, 2c). During this growth phase, the volume of the oocyte increases about one thousand-fold. Ovaries in this stage contain immature oocytes and have a gonadosomatic index (GSI) of less than 2% (Selman and Wallace, 1989).

**Vitellogenic phase:** The oocytes increase in size due to endogenous and exogenous vitellogenesis. At the end of endogenous vitellogenesis, the Balbiani bodies disappear from the oocyte cytoplasm completely (stage 3). Next is a presentation of cortical alveoli at the oocyte cytoplasm (stage 4). The cortical alveoli are carbohydrate vesicles that stain for proteins and carbohydrates: for example; alcian blue, toluidine blue and periodic acid & Schiff reagents. The staining with the periodic acid & Schiff reagents results in pink cortical alveoli (stage 4) at the oocyte cytoplasm. However, the cortical alveoli are difficult to preserve. Thus, they lose their staining properties and assume a vacuolar appearance (Wallace *et al.*, 1987). Subsequently, the oocytes develop through exogenous vitellogenesis (stage 5), which is a long growth process under the control of pituitary gonadotropins. The enlargement of the oocytes is mainly due to accumulation of yolk that contributes 80-90% of egg dry weight (Wallace *et al.*, 1987). During stage 5, there is an increase of hepatic synthesis and a secretion of vitellogenin, lipophosphoprotein, and yolk protein precursor in response to the circulation of estrogen. The vitellogenin is delivered to the oocytes and forms yolk bodies by micropinocytosis. The yolk bodies accumulate in yolk globules and form yolk pellets. The nucleus of the stage 5 oocyte is reduced in size but still located at the centre of the oocyte.

**Maturation phase:** The nucleus of the vitellogenic oocytes starts migrating to the animal pole (germinal vesicle migration; GVM; stage 6). Next, the nuclear envelope of the oocyte breaks down (GVBD; stage 7). The oocytes have then reached the final maturation phase. The process of oocyte maturation is usually rapid and accomplished within 24 hours (Selman and Wallace, 1989). Finally, the mature oocytes are hydrated and released into the ovarian cavity (ovulation).

**Atresia:** Atresia is a degenerative process in which the oocytes at various stages stop growing and undergo rupture and resorption *in situ* by granulosa cell phagocytosis. Yolks are liquefied, forming irregular drops and staining acidophilic. Yolk residual may be seen as brown or black bodies. Atresia commonly occurs in fish ovaries during all development phases. In fact, there is no difference between the sizes of developing and atretic oocytes. Thus, fecundity estimates based on oocyte size may be affected by atresia (Macer, 1974). Female gonadal maturation may occur only once or else several times a year, depending on the species (reproductive cycle) and on environmental conditions (season, water and food).

### **Male gonadal development**

Male gonadal development is called spermatogenesis. The process involves mitotic proliferation to produce large numbers of sex cells and meiotic division to generate genetic diversity and half the chromosome number. The process is initiated by environmental factors. The brain receives the signals and sends them to the hypothalamus. The hypothalamus releases GnRH to the pituitary gland, resulting in the production of GtHs. Initially, GtH I stimulates the Leydig cells of the testis to produce testosterone. The testosterone causes spermatogonia (2n) to undergo mitotic division to primary spermatocytes (2n). The primary spermatocyte enlarges in size and reduces the chromosome by half at the first meiosis, which results in secondary spermatocytes (n). The secondary spermatocytes then develop into spermatids at the end of the meiotic division. Next, GtH II peaks and stimulates the Leydig cells to produce 11-ketotestosterone, which induces spermatids to form a tail and become spermatozoa. The process is called spermatogenesis. The spermatozoa are the mature sperms in the lumen of the testis. A steroid called 17 $\alpha$ , 20 $\beta$ -dihydroprogesterone, which stems from GtH II, causes the spermatozoa to dilute with seminal fluid and results in a sperm suspension called milt. This process is called spermiation. In nature, mature males with ripe gonads can be found over a longer period than mature females with ripe gonads. The spermatozoa may be ready for several weeks during the spawning season (Fig. 2).

## **Staging of gonadal development**

The staging of gonadal development is necessary for propagation by hormonal administration. Effective hormone treatment requires the correct gonadal stage, which depends on the reproductive characteristics of the sex and species.

### **Staging of the female gonad**

Gonadal development can be staged by various methods. Some methods may be quick and easy while other methods may be complex, expensive and time-consuming. Each method has some advantages as well as disadvantages. Female gonadal development can be staged in the following way.

#### ***External appearance of abdomen***

In the female, a large, soft belly and swollen genital papilla indicates readiness for hormonal induction. External examination requires skill and experience for good results. Selection of broodstock based on these characteristics is fast, easy and causes little stress. However, the method is less useful for inexperienced farmers, and for the examination of new fish species, which might have different abdominal appearances.

#### ***Ovarian biopsy***

Biopsy techniques can be used to sample eggs for staging by size (diameter) and appearance (color). The biopsy techniques are:

- 1) cannulating gonoduct with a fine polyethylene tube and aspirating a few dozen oocytes by mouth or by using a syringe. It is necessary to sample oocytes from the same part of the ovary in each fish to reduce sampling bias. This technique works in carps, catfish, milkfish, mullet, rabbitfish, seabass and grouper etc (Harvey and Carolsfeld, 1993).
- 2) puncturing the abdominal wall with a hypodermic needle and withdrawing some oocytes. The technique is effective and quick in less ripe gonads and in some species with fragile oviducts. The technique is less damaging than cannulation.
- 3) incising the abdominal wall and removing ovarian tissue. The technique is applied to large fish where the other biopsy techniques do not work. The sampled oocytes are cleared with clearing solution (40% formalin, 40% ethanol and 20% glacial acetic acid) to find the position of the germinal vesicle or nucleus of the oocytes, which may be classified into central (stages 2-5), migrating (stage 6) and peripheral (stage 7) germinal vesicles. Readiness for hormonal induction is indicated when one third of the oocytes have germinal vesicles in migrated and peripheral stages, while the rest have a central nucleus. Using clearing solution, it takes 1-2 minutes to clear up the oocyte yolk. The nucleus will only be visible for 4-5 minutes (Harvey and Carolsfeld, 1993).

#### ***Oocyte diameter and distribution***

The diameter of the oocytes can be measured by expelling the sample into a fixative solution of 5% phosphate-buffered formalin placed in a petri-dish. Using a microscope with an ocular micrometer, about 50 oocytes are measured. The average oocyte diameter as well as the size distribution can be used to predict the appropriate timing for hormonal induction, when compared to a reference. In milkfish for example, an average oocyte diameter of 750µm or more is the critical size for GnRH<sub>a</sub> treatment. Diameter distribution is useful in species where the diameter of the oocyte does not significantly increase after the completion of vitellogenesis (Harvey and Carolsfeld, 1993).

#### ***Ovary weight and oocyte morphology***

The technique needs a representative sample of the broodstock. Thus, a few fish (3-5) are sacrificed and ovaries dissected. The ovaries are weighed for calculation of the gonadosomatic index (GSI (%) = ovary weight/body weight x 100) and then processed for histological sectioning.

The GSI can be used to predict the gonadal stages of the fish, when compared to a reference. The histo-morphological structure of oocytes in the ovary is the most accurate method for oocyte staging. However, there are many oocytes in an ovary. Thus, the average oocyte stage is required to decide the ovarian stage. The stereological method is based on the Delesse Principle, which assumes that a random 2-dimensional section (histological slide) can be used to quantify the composition of a 3-dimensional object (ovary). Thus, the stereological method presents a composition of the ovary, which is occupied by oocytes at each stage. Although the method is effective, it requires expensive equipment, knowledge of stereology and is time-consuming. The method has been used to quantify ovarian composition and the maturity of some aquatic animals (Lowe *et al.*, 1982; MacDonald and Thompson, 1986).

### **Staging of the male gonad**

The staging of the male gonad is simpler and easier than the female. The ripe male can be staged in the following ways.

#### ***Secondary sexual characteristics***

Mature males show secondary sexual characteristics such as:

- 1) pearl organs on the bodies and pectoral fins of cyprinids,
- 2) distinct body colors, like dark and bright colors on the chins of tilapias or black spots on the pectoral fins of Giant gourami (Srisakultiew *et al.* 1994),
- 3) protruding genital papillae in *Clarias* spp.

#### ***Spermiating male***

Males generally produce milt in captivity. The spermiating male has sperm in the lumen of the testis and sperm duct. During the final stage of maturation in the male (hydration), seminal fluid is released in the lumen. The volume of sperm increases dramatically, and sperm become more fluid and diluted. The male may remain in this condition for several months without spawning (Harvey and Carolsfeld, 1993). Ripe males are easily distinguished by the release of milt, when the belly is pressed or squeezed.

### **Breeding Techniques**

Some cultured species spawn in captivity easily but some may not spawn at all. For those that do spawn, it may be asynchronously, or in a season not necessarily desired by the farmer for optimal management. Thus, breeding techniques play an important role for large-scale fry production. Breeding techniques can be divided into 2 categories.

#### ***Natural spawning***

Males and females are released together in a spawning pond where external cues are manipulated, (e.g. temperature, water exchange, water quality, photoperiod and presence of the nest), to stimulate the fish into spawning naturally. The spawners may be left to incubate their eggs, or else they may be separated, depending on their brooding behaviour. In Thailand, there are approximately 11 species where natural spawning is used (Table 1). This technique is also called uncontrolled breeding or semi-controlled breeding.

**Table 1.** Freshwater species that are reproduced by natural spawning

Common name	Scientific name	References
Giant gourami	<i>Osphronemus gouramy</i>	Srisakultiew <i>et al.</i> , 1994
Nile tilapia	<i>Oreochromis niloticus</i>	Pongsuwan and Sithimungka, 1989
Catfish	<i>Clarias macrocephalus</i>	Pongsuwan and Sithimungka, 1989
Catfish	<i>Clarias batrachus</i>	Pongsuwan and Sithimungka, 1989
Royal featherback	<i>Chitala blanci</i>	Supachalust, 1988
Spotted Featherback	<i>Chitala ornata</i>	Rodrarung and Meewan, 1996
Swamp eel	<i>Monopterus albus</i>	Kwanmuang <i>et al.</i> , 1993
Freshwater Garfish	<i>Xenentodon cancila</i>	Juntubtim, 1996
Drumfish	<i>Boesemania microlepis</i>	Pimolbutr and Pasugdee, 1994
Sand Goby	<i>Oxyeleotris marmorata</i>	Amatayakul <i>et al.</i> , 1995

### ***Hormonally induced spawning***

A hormone is administered, in order to stimulate the fish to spawn either naturally or artificially. This method is usually applied to cultured fish that have matured but lack the ability to spawn in captivity. However, the technique has become routine practice on fish farms because it is relatively easy, efficient and practical. The hormones used for manipulating fish maturation and ovulation include pituitary extract, HCG, and GnRH/LHRH plus their analogues, in combination with dopamine antagonist. Details of the hormones used in aquaculture are explained below.

#### *Fish pituitary extract (hypophysation)*

This method was established in 1931 by Houssay, who used fish pituitary extract or hypophysation to induce fish spawning (Harvey and Hoar, 1979). Fish pituitary glands are obtained from sexually maturing or mature donors either of the same or of a different species. The gland may be used fresh or stored in absolute alcohol or acetone. General computation of the hypophysation working dose is based on the fresh weights of the donor and the recipient:

$$\text{Working Dose} = \frac{\text{Weight of Donor Fish (kg)}}{\text{Weight of Recipient fish (kg)}}$$

Fish are induced to spawn by administering the working dose once or twice (Table 2, p 16). For example, a single injection, of 1.4-2.0 times the working dose of the hypophysation, induced *B. gonionotus* to spawn 4-6 hours after administration (Tavarutmaneegul *et al.*, 1992). This method is practical in the field, because simple equipment and small amounts of materials are needed. The whole pituitary gland contains other pituitary hormones in addition to the gonadotropins, which may increase the efficacy of hypophysation (Donaldson, 1986).

The method however, has some disadvantages:

- Many donor fish have to be killed to obtain pituitary glands.
- The pituitary extract is unreliable, due to poor standardization.
- In China, there is some evidence that fish may develop an immune reaction to repeated injections.
- When fresh pituitary extract is used, the donor fish may transmit a disease to the recipient.
- The weight of the donor fish may be unknown, when stored or dried pituitary glands are used.

Using dried pituitary glands, Rowland (1983) reported that a very low dose (1 mg. carp pituitary gland per kg. of the recipient) induced oocyte maturation without ovulation in the golden perch (*Macquaria ambigua*), whereas a somewhat higher dose (5 mg/kg) induced 100% ovulation. However, the fertilization rate was more variable at 5 mg/kg than at the relatively high dose of 10 mg/kg. On the other hand, a really high dose (15 mg/kg recipient) reduced hatchability when compared to 10 mg/kg, which appeared to be the optimal dosage for the species.



Although the method solves the problem of the unknown weight of the donor, it requires a fine electrical balance for weighing the gland to the nearest milligram. The technique has been improved by using a lyophilised pituitary powder, which is a crude preparation of fish gonadotropin. This powder is more stable, as well as having a longer shelf life and known potency of the gonadotropin content, than the fresh pituitary gland of either a carp or a salmon (Yaron and Levavi-Zermonskey, 1986). Induced spawning with a lyophilised pituitary gland is quite expensive and only efficient when used with closely related species. Furthermore, the hypophysation approach may later face problems as new fish species are introduced to aquaculture, and closely-related fish pituitaries are difficult to obtain (Yaron and Zohar, 1993)

#### *Human Chorionic Gonadotropin*

Human Chorionic Gonadotropin (HCG) is extracted from the urine of pregnant women. This gonadotropin is a complicated glycoprotein, with a molecular weight of about 30,000 Dalton. It is uniform in a given batch and can therefore be standardized. HCG is also available as a pharmaceutical product. The use of HCG eliminates the need for killing fish and the whole pituitary preserving process (Donaldson, 1986). However it works in some fish gonadotropin receptors, but not in others. Sometimes, the HCG may work on the male but not the female. In addition, the effective dosage of HCG may vary from species to species, depending on how closely related the fish endogenous gonadotropin is to HCG (Lam, 1982). Nonetheless, HCG alone, or in combination with hypophysation, has efficiently induced ovulation in a number of fish species. The method is common practice on many fish farms, despite the fact that HCG is a relatively expensive product.

#### *Gonadotropin-Releasing Hormone, or luteinizing hormone-releasing hormone, their analogues and dopamine antagonists*

The gonadotropin-releasing hormone (GnRH), or the luteinizing hormone which releases another hormone (LHRH), is a short peptide hormone, composed of 10 amino-acids. The peptide is similar in most teleosts and mammals (Donaldson, 1986). Analogues (GnRH<sub>a</sub> or LHRH<sub>a</sub>) are molecules in which some amino-acids have been substituted, in order to increase the half-life of the molecule in the fish and so increase its capacity to bind with GnRH receptors in the pituitary gland. Thus, the efficacy of the GnRH<sub>a</sub>/LHRH<sub>a</sub> will be higher than that of natural forms of the GnRH/LHRH. The use of either GnRH/LHRH or GnRH<sub>a</sub>/LHRH<sub>a</sub> for spawning induction has several advantages over the traditional hypophysation technique. The GnRH/LHRH or GnRH<sub>a</sub>/LHRH<sub>a</sub> is a small peptide molecule. Thus, it can be synthesized into its native form and also into altered forms (analogues), with a slow rate of degradation. Therefore, lower doses are required when using analogue forms (Zohar *et al.*, 1989). GnRH/LHRH and its superactive analogues (GnRH<sub>a</sub>/LHRH<sub>a</sub>) are unlikely to elicit immunological responses, like some heterologous gonadotropins (hypophysation and HCG) do, and are therefore potentially less harmful to the recipient fish. In addition, GnRH/LHRH (GnRH<sub>a</sub>/LHRH<sub>a</sub>) stimulates the secretion of the fish's own GtHs. This means that it is not species-specific and can be successfully applied to a great variety of fish species.

Studies on the brain's regulation of hypophysial function by Peter *et al.* (1986) revealed the presence of two hypothalamic hormones that control the release of GtHs from the pituitary gland. The first is GnRH, which stimulates GtHs release. The second is dopamine, an amine which antagonises the release of the GnRH in most teleosts, and thus reduces the production of GtHs from the pituitary gland. Therefore, injecting either GnRH/LHRH or GnRH<sub>a</sub>/LHRH<sub>a</sub> alone is generally ineffective in inducing ovulation in cultured fish, due to the strong inhibitory effect of dopamine on GtHs secretion. This has been found to be the case with goldfish, common carp and Chinese carps (Peter *et al.*, 1986; Lin *et al.*, 1986). Lin and Peter (Peter *et al.*, 1988) developed the "Linpe method", by injecting a combination of a GnRH<sub>a</sub>/LHRH<sub>a</sub> and a dopamine antagonist (domperidone, pimozide or metoclopramide), in order to induce the ovulation and spawning of cultured fish. The Linpe method has been widely and effectively applied in many cultured fishes throughout the world (Lin and Peter, 1996). In Thailand, the Linpe method has also been used

successfully in many fish species, as shown in Table 2, p.16. However, it is important to note that the dopamine antagonists vary in their efficacy amongst different fish species (Zohar, 1988; 1989).

In some cases, GnRH $\alpha$  is used in combination with carp pituitary extract or HCG, in order to induce the ovulation and spawning of cultured fish species (Peter et al., 1988a; Table 2). In addition, the sustained release of GnRH from slow-releasing vehicles (cholesterol, cholesterol-cellulose or biodegradable polymers), has been successfully used to induce continuously high GtHs levels and/or ovulation in salmonids (Crim and Glebe, 1984), goldfish (Sokolowska et al., 1984), milkfish (Marte et al., 1987), sea bass (Almendras et al., 1988) and gilthead sea bream (Zohar, 1988). The rate of GnRH release can be determined by altering the proportion of cellulose in the cholesterol pellet (Sherwood et al., 1988).

## Embryogenesis

Many fish species require that their embryos (eggs) incubate and hatch in open water. Eggs are broadcast in the water column and either float or sink; adhesive eggs may attach to plants or hard substrates (rock or gravel). Eggs from other fish are laid in a nest, and parent(s) provide a constant water flow by fanning their fins. Some fish also incubate eggs in their mouths where movement of the gill plates provides both gentle tumbling and water circulation. Artificial incubation and hatching of fish embryos simulate these natural processes. In the wild, eggs (or egg masses) are susceptible to predation, and are easily damaged by the continual change of the natural environment. The advantage of man-made hatcheries is that the environment can be controlled and manipulated.

Developing embryos and newly-hatched larvae (fry) are the most sensitive and delicate of the stages in the life history of a fish. Therefore, great care must be taken to provide them with the proper incubating and hatching environment. Water temperature, light, water quality, water flow, shock prevention, and type and size of the egg are very important considerations.

**Embryogenesis** is the process by which the embryo is formed and develops. It starts with the fertilization of the ovum, egg, which, after fertilization, is then called a zygote. The zygote undergoes rapid mitotic divisions, the formation of two exact genetic replicates of the original cell, with no significant growth (a process known as cleavage) and cellular differentiation, leading to development of an embryo. It occurs in both animal and plant development, but this article addresses the common features among different animals.

**The zygote:** The egg cell (and hence the fertilized egg) is always asymmetric, having an "animal pole" (future ectoderm and mesoderm), two of three primitive tissue types, and a "vegetal pole" (future endoderm), it is also covered with different protective envelopes. The first envelope, the one which is in contact with the membrane of the egg, is made of glycoproteins and is called vitelline membrane. Different taxa show different cellular and acellular envelopes.

**Cleavage:** The zygote undergoes rapid cell divisions with no significant growth, producing a cluster of cells that is the same size as the original zygote. The different cells derived from cleavage, up to the blastula stage, are called blastomeres. Depending mostly on the amount of yolk in the egg, the cleavage can be holoblastic (total) or meroblastic (partial).

**2-cell stage:** The first cleavage furrow, ending the first zygotic cell cycle, is vertically oriented, as is usual until the 32-cell stage. The furrow arises near the animal pole and progresses rapidly towards the vegetal pole, passing through only the blastodisc and not the yolky region of the egg. Near the bottom of the blastodisc the furrow changes to a horizontal orientation to undercut the blastodisc, but still leaves the cells only partly cleaved from the underlying yolky region. The two blastomeres are of equal size and appear otherwise undistinguished from one another. The following several cleavages are strictly oriented relative to the first one. However, the eventual

axes of body symmetry (i.e. the dorsal-ventral and anterior-posterior axes) apparently cannot be predicted with any certainty from the orientation of the cleavage.

**4-cell stage:** The two blastomeres cleave incompletely and in a single plane that passes through the animal pole at right angles to the plane of the first cleavage. Hence, cycle 3 begins with 4 blastomeres in a 2x2 array. A view from the animal pole reveals that the blastodisc is ellipsoidal in shape. The second cleavage plane is oriented along the longer axis.

**8-cell stage:** Cleavages ending cycle 3, still incomplete, occur in two separate planes, parallel to the first one, and on either side of it. They cut the blastodisc into a 2x4 array of blastomeres. As the dechorionated embryo usually lies in a dish, the 4-cell aspect, rather than the 2-cell aspect, faces the observer. This "face" view is along the odd numbered cleavage planes (furrows 1 and 3 are visible;). The dechorionated embryo tends to lie in the same orientation through late blastula stages (through the high stage).

**16-cell stage:** The fourth set of cleavages also occur along two planes, parallel to and on either side of the second one, and produces a 4x4 array of cells. Use care to distinguish this stage from the 8-cell stage, because they look similar in face. For the first time some of the cells now become completely cleaved from the others. These 'complete' cells are the 4 most central blastomeres, the quartet that is entirely surrounded by other cells. Their complete cleavage occurs near the end of the 16-cell stage because of the way the cleavage furrows undercut the blastodisc from the center, going outwards towards the blastodisc margin. Indeed, the undercutting furrows still do not reach the margin, and the 12 cells surrounding these 4 central ones, the so-called marginal blastomeres, remain connected to the yolk cell by cytoplasmic bridges. From this stage onwards until the midblastula period the cleavages completely partition most or all of the nonmarginal blastomeres, but still incompletely partition the marginal ones.

**32-cell stage:** The cleavages ending cycle 5 often occur along four parallel planes, rather than two, lying between those of the first and third cycles. However, oblique orientations of the furrows are now common. Frequently the 32 blastomeres of this stage are present in a 4x8 array, but other regular patterns, as well as irregular ones involving one or more of the blastomeres also occur. In a side view one usually sees two **tiers**, or horizontal rows, of blastomeres between the margin and the animal pole. This is because the plane of the blastodisc is curved; marginal cells are more vegetal, and they lie partly in front of the nonmarginal ones positioned closer to the animal pole.

**64-cell stage:** Cleavages ending the sixth cycle pass horizontally, so that in an animal polar view the blastomere array may look similar to the 32-cell stage, although the cells entering cycle 7 are smaller. From the side the cell mound looks distinctly higher. For the first time some of the blastomeres completely cover other ones. The buried cells, or deep cells, each arise as one of the two daughters of the 4 central blastomeres that were present at the 32-cell stage. The other daughter remains superficial, in the top-most tier of what is now the enveloping layer (EVL) of the blastodisc. During the same cleavage the horizontal divisions of marginal blastomeres present at cycle 6 produce two EVL sister cells, and in a face view of the 64-cell stage one sees three tiers of EVL cells.

**Morula** The morula is produced by embryonic cleavage, the rapid division of the zygote. After reaching the 16-cell stage, the cells of the morula differentiate. The inner blastomeres will become the inner cell mass and the blastomeres on the surface will later flatten to form the trophoblast. As this process begins, the blastomeres change their shape and tightly align themselves against each other to form a compact ball of cells. This is called compaction and is likely mediated by cell surface adhesion glycoproteins.

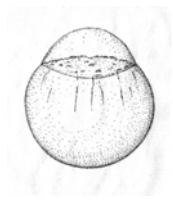

Zygote

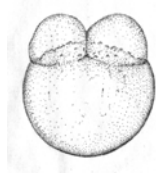

2 cell

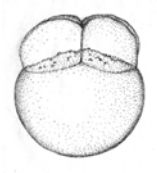

4 cell

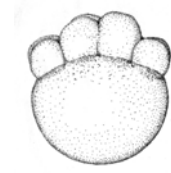

8 cell



16 cell



32 cell

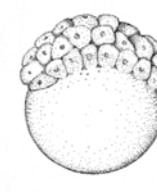

64 cell

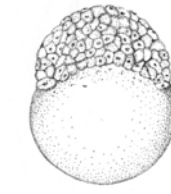

Early blastula

————— Morula stage —————

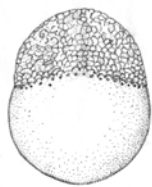

Late blastula

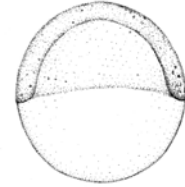
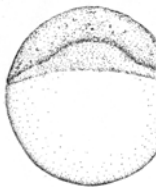

Gastrula stage

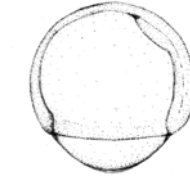

Organogenesis



Morphogenesis

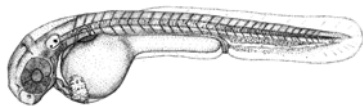
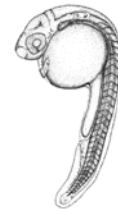

Hatch Out



Larva or Fry

**Blastula and Gastrula** After the cleavage has produced over 100 cells, the embryo is called a blastula. The blastula is usually a spherical layer of cells (the blastoderm) surrounding a fluid-filled or yolk-filled cavity (the blastocoel).

During gastrulation cells migrate to the interior of the blastula, consequently forming two (in diploblastic animals) or three (triploblastic) germ layers. The embryo during this process is called a gastrula. The germ layers are referred to as the ectoderm, mesoderm and endoderm. In diploblastic animals only the ectoderm and the endoderm are present.

The first stage of gastrulation begins with the epiboly of the EVL and the deep cells over the YSL. This epiboly is driven by the migration of nuclei and cytoplasm in the YSL and attachments between the YSL and the EVL. Intercalation of the deep cells with the EVL help drive this movement. At about 50% of epiboly, a fate map similar to that of the *Xenopus* can be derived. The EVL develops into an extraembryonic membrane and does not contribute to the embryo.

The second stage of gastrulation occurs when the leading edge of the epibolizing blastoderm thickens. The dorsal side forms a larger thickening and is known as the **embryonic shield**. The deep cells in the embryonic shield form two layers. The **epiblast** forms near the surface and will give rise to the ectoderm. The **hypoblast** forms next to the YSL and will form a mixture of endoderm and mesoderm. The hypoblast is formed through involution and/or ingression. The movement of cells in the hypoblast are similar to the involuting mesoderm of amphibians. The end result of gastrulation is an asymmetric involution of cells that form the dorsal structures of the embryo. The following processes occur to place the cells in the interior of the embryo. **Epiboly** - expansion of one cell sheet over other cells. **Ingression** - cells move with pseudopods. **Invagination** - forming the mouth, anus, and archenteron. **Delamination** - the external cells divide, leaving the daughter cells in the cavity. **Polar proliferation**

Other major changes during gastrulation: Heavy RNA transcription using embryonic genes; up to this point the RNAs, Used were maternal (stored in the unfertilized egg). Cell start major differentiation processes, losing their pluripotentiality.

**Organogenesis** is the process by which the ectoderm, endoderm, and mesoderm develop into the internal organs of the organism. The germ layers in organogenesis differ by three processes: folds, splits, and condensation. At some point after the different germ layers are defined, **organogenesis** begins. The first stage in vertebrates is called **neurulation**, where the neural plate folds forming the neural tube. Other common organs or structures which arise at this time include the heart and somites

The proceeding graph represents the products produced by the three germ layers.

<b>Germ Layer</b>	<b>Category</b>	<b>Product</b>
Endoderm	General	Gastrointestinal tract
Endoderm	General	Respiratory tract
Endoderm	General	Endocrine glands and organs (liver and pancreas)
Mesoderm	General	Bones
Mesoderm	General	Most of the Circulatory system
Mesoderm	General	Connective tissues of the gut and integuments
Mesoderm	General	Excretory Tract
Mesoderm	General	Mesenchyme
Mesoderm	General	Mesothelium
Mesoderm	General	Muscles
Mesoderm	General	Peritoneum
Mesoderm	General	Reproductive System

Mesoderm	General	Urinary System
Mesoderm	Vertebrate	Chordamesoderm
Mesoderm	Vertebrate	Paraxial mesoderm
Mesoderm	Vertebrate	Intermediate mesoderm
Mesoderm	Vertebrate	Lateral plate mesoderm
Ectoderm	General	Nervous system
Ectoderm	General	Outer part of integument
Ectoderm	Vertebrate	Skin (along with glands, hair, nails)
Ectoderm	Vertebrate	Epithelium of the mouth and nasal cavity
Ectoderm	Vertebrate	Lens and cornea of the eye
Ectoderm	Vertebrate	Melanocytes
Ectoderm	Vertebrate	Peripheral nervous system
Ectoderm	Vertebrate	Facial cartilage
Ectoderm	Vertebrate	Dentin (in teeth)
Ectoderm	Vertebrate	Brain (rhombencephalon, mesencephalon and prosencephalon)
Ectoderm	Vertebrate	Spinal cord and motor neurons
Ectoderm	Vertebrate	Retina
Ectoderm	Vertebrate	Posterior pituitary

In most animals organogenesis along with **morphogenesis** will result in a larva. The hatching of the larva, which must then undergo metamorphosis, marks the end of embryonic development.

**Morphogenesis** is one of three fundamental aspects of developmental biology along with the control of cell growth and cellular differentiation. Morphogenesis is concerned with the shapes of tissues, organs and entire organisms and the positions of the various specialized cell types. Cell growth and differentiation can take place in cell culture or inside of tumor cell masses without the normal morphogenesis that is seen in an intact organism.

### **Egg Incubation**

Artificial incubation of fish eggs is a hatchery practice that will increase the economic efficiency of a commercial fish culture operation. Hatching rates and survival will be increased using artificial incubation. Also, removal of the eggs from the parents may increase egg production by shortening the time for another spawning to occur.

#### ***Proper Incubation of Fish Eggs***

Fish embryos and larvae are susceptible to many types of organic or inorganic materials dissolved or suspended in the water. These may include gases, minerals, metals, and particulate matter from rocks, soil, plants and animals. It is essential to know the water quality standards for embryos and larvae of the particular fish species. General water quality standards used in fish culture can be used as a reference point for hatchery water.

#### ***Hatching temperature and dissolved oxygen:***

Spawning of brood stock, embryo development, survival, and growth of fish larvae occur within a narrow range of water temperatures. Incubation temperature has a direct effect on the timing of embryonic development and thus determines hatch rate. Fish development and hatching is delayed at low temperatures, and accelerated at high temperatures. Incubating temperatures are also known to modify the behavior of larvae and determine certain morphological characteristics. There is an optimum temperature required for each developmental life stage, and these vary among species. Water temperatures should be maintained with minimal fluctuations, preferably no more than  $\pm 1^{\circ}\text{C}$  ( $2^{\circ}\text{F}$ ) from optimal. If a species' optimum water temperature for incubation is unknown, use the optimum temperature of a related species or of a fish that inhabits a similar geographic area. In general, optimum temperatures for spawning, incubating, and rearing newly-hatched tropical freshwater species are  $24\text{-}28^{\circ}\text{C}$  ( $75\text{-}82^{\circ}\text{F}$ ). Avoid temperatures above or below this range. Poor embryo survival, low hatch success, reduced growth rates, larval deformities, and increase in

fry/larvae diseases often result from temperature fluctuations or temperatures outside the optimum range for the species. Take the embryo development of Silver carp as an example, when the water temperature is 18°C, the incubating process takes 61 hours; when the water temperature is 28°C, only 18 hours are needed.

Dissolved oxygen content in pond water should not be lower than 4--5mg/l. Below 2mg O<sub>2</sub>/L, the embryo can not develop normally.

The amount and incidence of light received during incubation can affect both fish development and larval survival. Incubation of fish embryos should occur in either dim light or darkness. Light can also be used to synchronize hatching. Many species of fish will not hatch in daylight, therefore, if the lights are switched off, hatching will occur a few hours later.

During incubation, a constant water flow is essential for preventing accumulation of waste products and allowing gas exchange between the egg and the surrounding water. Constant motion also appears to be necessary for successful hatching for some species of fish. Proper water flow also reduces mechanical abrasion. Eggs of many fish are sensitive to mechanical shock and should not be moved during certain times during development. For example, eggs of salmon and trout can only be moved during the first 36 hours after fertilization. Thereafter, the eggs are kept still until the embryo eye becomes visible. The amount of water flow necessary for proper incubation of fish embryos depends largely on egg density (how heavy and large eggs are in water). Some fish eggs are quite dense and sink to the bottom when released. Other eggs become buoyant as they "water-harden" and free-float in the water column or at the surface. Some eggs have hair-like structures or specialized coatings that make them sticky. Some eggs have an oil drop in them and they float on the surface.

Egg diameter is also an important consideration during incubation. Screen mesh size should prevent the passage of eggs while allowing sufficient water circulation and deterring debris collection. Most ornamental fish eggs are around 0.8 mm in diameter, however, the size range is wide. Eggs can be as large as 1.5-2.0 mm for some ornamental catfish, and as small as 0.4 mm for gobies.

### ***Types of Fish Egg Incubators***

A wide variety of devices are used for incubating fish eggs. For practical purposes, we have classified fish egg incubators into three major types: egg mats, trays, and conical incubators. Their use is based primarily on the density of the eggs to be hatched, their stickiness, and the sensitivity of the eggs to mechanical shock. Figure 1, Figure 2, and Figure 3 illustrate the three general types of fish egg incubators.

Egg mats are used primarily for adhesive eggs. By simulating a spawning substrate (plants, rocks, etc.), they serve as egg collectors and provide a place for egg attachment. Since egg mats also serve as a stimulus for spawning, they are also known as spawning mats. Mats consist of bundles of fibrous material arranged in a variety of forms and made from a variety of different materials (plastic shreds, air filters, spanish moss, coconut fibers, horse hairs, etc.) ([Figure 1, a and b](#)). Typically, egg mats are suspended in the water column or laid along the bottom or sides of the spawning container. The mats can be removed from the spawning container and suspended in the air where they can be kept moist at all times with a fine spray of water. The oxygen content of air is about 20 times more than water, thus increasing gas exchange between the egg and the thin film of water that surrounds them. For spawning and incubating eggs of many ornamental fish, such as angelfish, discus, and corydoras catfish, mats are often replaced with bottle brushes, pots, or slates that are made of plastic, glass, clay or rock ([Figure 1c](#)).

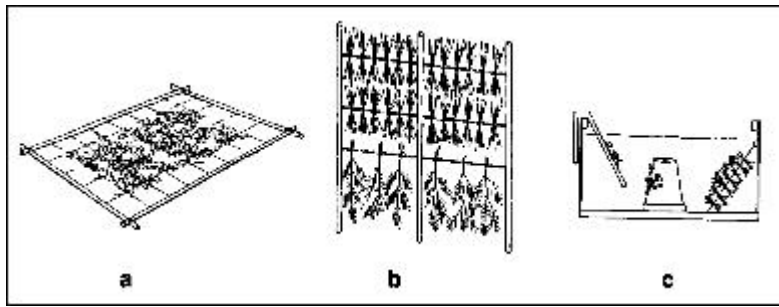

Figure 1. Egg mats: frameworks with a) spanish moss and b) bundled fibers; c) slate, clay pot and bottle brush.

A tray-type incubator consists of a container that is screened or perforated, through which a flow of water permeates to supply the eggs with oxygen and flush away waste products (Figure 2). They are often designed so that water penetrates the tray from below and flows out over the upper edge. Since the eggs lay over a screen, tray-type incubators are ideal for fish eggs that can be injured by movement during incubation. Tray incubators can be stacked and provide easy access for removal of dead embryos. The newly-hatched larvae can drop through the screen holes minimizing handling and removal of the egg shells.

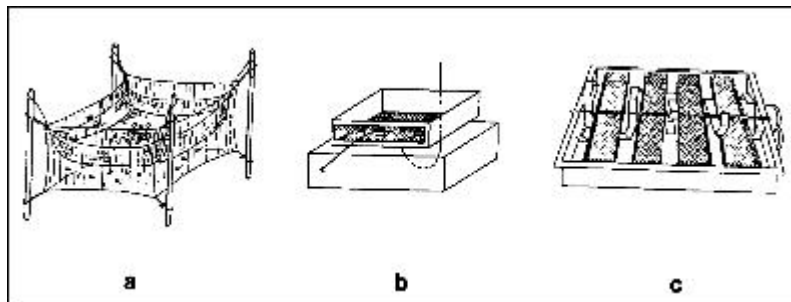
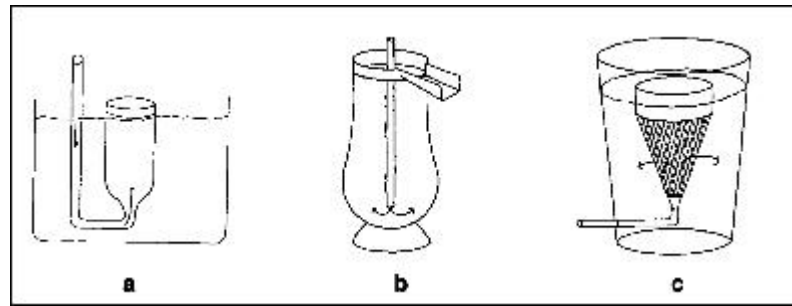

Figure 2. Incubators: a) traditional "happa", framework with fine mesh, b) basket-type, and c) multiple baskets with paddlewheels.

Tray-type incubators were originally designed to hatch trout and salmon eggs. The eggs of salmonid fish are large, non-adhesive and laid in a gravel bed during natural spawning. The eggs must remain still and in the dark since abrupt movements and direct sunlight affect embryonic development. Tray-type incubators also are formed into baskets and commonly used to incubate and hatch channel catfish eggs. The baskets are placed in a water trough, and paddlewheels, which are attached to the trough, provide aeration and gentle circulation of the water. Baskets can also be placed outside the spawning tank and then used as incubators. The "happa" or net enclosures traditionally used for spawning, egg incubation, and larval rearing of common carp function similarly to basket or tray incubators.

Fish eggs that are non-adhesive and require constant movement are commonly incubated in conical shaped tanks or jars where water flows into the bottom or top of the container (Figure 3). In this type of incubator the eggs are gently suspended and constantly tumble in the lower portion of the jar. The flowing water not only insures that good quality, well oxygenated water is constantly being replaced in the jar, but the tumbling of the eggs keeps them from collecting debris which can lead to fungal infections. These types of incubators can be set in series above a rearing tank. The larvae pour out of the incubators into the rearing tank as they hatch. A soft meshed material can be shaped into a cone and used as an incubator. It is advantageous to use screen because greater surface area is provided for water to flow out, preventing the eggs, yolk-sac larvae or the larvae from becoming crushed. Incubators made of net material require structural support and must be suspended inside a larger tank or placed into the rearing tank.





*Figure 3. Incubators for non-adhesive eggs:  
All three devices provide gentle water circulation.*



## FRESHWATER AQUACULTURE TECHNIQUES FOR RURAL DEVELOPMENT

### Aquaculture System

#### SUBJECT PLAN

<b>Subject</b>	Freshwater Aquaculture Techniques for Rural Development: Culture systems –principles and techniques
<b>Date/Time</b>	4 July 2007, 13.00-16.30 hrs
<b>Officer-in-charge</b>	Mr. Arkom Choomthi
<b>Objectives</b>	After the subject, The participants will be able to: <ol style="list-style-type: none"> <li>1. Understand principles of aquaculture and integrated agriculture-aquaculture systems</li> <li>2. Appreciate concepts related of aquaculture and integrated agriculture-aquaculture systems</li> <li>3. Apply appropriate aquaculture and integrated agriculture-aquaculture systems and their techniques for extension works</li> </ol>
<b>Topics</b>	<ol style="list-style-type: none"> <li>1. Introduction of aquaculture</li> <li>2. Principles of aquaculture systems and techniques</li> <li>3. Introduction of integrated agriculture-aquaculture</li> <li>4. Principles of integrated agriculture-aquaculture systems and techniques</li> </ol>
<b>Detailed Activity</b>	
<b>Time</b>	<b>Sub-activity</b>
<b>4 July 2007</b>	
<b>13.00-14.30</b>	1. Introduction and explain of principles of aquaculture Systems and techniques
<b>14.45-16.30</b>	2. Introduction and explain of principles of aquaculture Systems and techniques

## **AQUACULTURE SYSTEM**

*Arkorn Choomthi  
Department of Fisheries, Thailand*

### **INTRODUCTION**

It remains uncertain as to the precise time or indeed location that aquaculture emerged. The archaeological record nevertheless illustrates that fish and shellfish have always been important sources of food to humankind. Early Neanderthal (500,000 years before present {BP}) and Cro-Magnon (25-10,000 BP) man are both known to have used fish hooks and nets and some sites suggest that both groups may have constructed primitive ponds that held fish. It is doubtful however, that these early hominids provided any direct care for their captives. Nonetheless, the intentional impoundment of aquatic organisms for later use as food or otherwise, symbolizes the first stage in the development of controlled farming of the aquatic environment. This protoaquaculture was developed further by the Egyptians of Dynastic times, some 4000 years ago.

A defining moment in the development of aquaculture was the demonstration that fish could be induced to spawn artificially. This finding, elaborated in Brazil in 1934, drove aquaculture forward by eliminating the need to collect wild seed or broodstock. This freedom brought about the revolution that was needed to support the rapid growth of the industry on a global scale. The development of methods for rearing larvae and controlling the reproductive cycle of aquatic species in general has created a hugely diverse industry of significant economic value. As researchers have discovered more about the life cycles of cultured aquatic organisms and the stimuli that encourage their development, aquaculturists have adapted their systems to gain greater control over production-related factors: growth, sexual maturation, reproduction, disease control and immunology. More recent has been the trend towards ensuring the safety and quality of the final product as well as developments in the culture of novel, non-food organisms. Today, aquaculture is practiced in fresh, brackish, and marine waters, in tropical through arctic conditions, in inland lakes and ponds through to large offshore cage operations.

An characterization of aquaculture is that proposed by the Food and Agricultural Organization of the United Nations: "The farming of aquatic organisms including fish, mollusks, crustaceans and aquatic plants with some sort of intervention in the rearing process to enhance production, such as regular stocking, feeding, protection from predators, etc. Farming also implies individual or corporate ownership of the stock being cultivated."

### **CATEGORIES OF AQUACULTURE**

In general, aquaculture production can be categorized as extensive, semi-intensive and intensive in form. Extensive aquaculture is characterized by low to no inputs (food, fertilizer, etc.) and low stocking densities. Extensive aquaculture is practiced in lakes, reservoirs and lagoons. Often, extensive aquaculture incorporates the culture of two or more species in the same water body (polyculture). Good examples of extensive aquaculture are seen in East and South-East Asia, as illustrated by the Ganges baor or ox-bow lake systems of Bangladesh. Semi-intensive aquaculture, which is often integrated with agricultural production, is distinguished by increased stocking rates and the requirement for some level of input, such as food, fertilizer, chemicals, etc. Integrated systems, as seen in China, incorporate fish production with the rearing of pigs and chickens (the feces of which is used to fertilize ponds), ducks (that churn sediment and assist in nutrient turnover), plants (which may be used as food), etc.

In marked contrast to other forms of aquaculture, intensive production systems are typified by the need for total control over the production cycle. Examples of intensive aquaculture include the cage cultivation of tilapia, pond production of hybrid catfish. Intensive aquaculture generally



demands total provision of feeds, chemicals, fertilizers, etc. and may also incorporate more sophisticated levels of intervention: control of reproduction, larval rearing, vaccination and so forth.

Intensification of aquaculture operations is constrained by a variety of factors, which include competition for water with other resource users (agriculture, fishermen, recreationists, etc.) and an increased demand for high quality water. The cost associated with the construction of new aquaculture facilities is generally high, today often exceeding a million dollars or more. With this increased level of investment, vulnerability to catastrophe is enhanced and hence the business becomes more risky. Many of the species reared under intensive conditions are fed with feeds that incorporate a high level of fishmeal as the protein source. The decline in the availability of fishmeal (and fish oils) and competition for its use (chicken, pig and other animal feed industries) has become problematic in economic terms. More expensive feed and chemical inputs demanded by intensive aquaculture has impacted the industry's profitability. Together with these economic factors, the level of stress experienced by animals held under intensive conditions increases and this elevates the chances of serious disease outbreaks occurring. Associated with an increased biomass in a production system is an enhancement in sophistication of the technological production environment. This in turn provides a higher demand for a skilled labor force with good management skills. The latter are expensive and indeed, often unavailable in the workforce. Accompanying aquaculture intensification are amplified problems with effluent outputs. In many countries, legislation has been enacted in efforts to reduce the potential environmental impact of aquaculture and this, in some instances, has forced closure of operations or reduced their production potential.

## **TYPES OF AQUACULTURE**

Within intensive, semi-intensive and intensive aquaculture methods there are numerous specific types of aquaculture systems, each has benefits and applications unique to its design.

### **POND CULTURE**

Pond aquaculture is the use of purpose-built earthen ponds, generally with water supply and drainage infrastructure incorporated, to grow fish and crustaceans. Ponds are the most widely used structure for commercial aquaculture production and are most commonly used in fresh and brackish water aquaculture. In general, ponds for aquaculture production are static (i.e. no regular water exchange) however, intensive systems with high stocking and feed rates and regular water exchange are utilised to produce some specie such as catfish and tilapia.

#### **Advantages of Pond Culture**

- Can be relatively cost effective, particularly if gravity fed and drained
- Some control over growing conditions (e.g. nutrient inputs)
- Minimize loss of stock through escapement or predation compared to more extensive operations

#### **Disadvantages of Pond Culture**

- Moderate to high land requirement and construction costs
- Little control over ambient environmental conditions (e.g. temperature)
- Stock management may be difficult
- May have some water consumption where evaporation is high

## **Pond System**

There are several types of pond currently used in aquaculture. Some of these, such as barrage ponds (i.e. ponds filled by rainwater or springwater), diversion ponds and sunken ponds, use the natural topography of the land. Tidal ponds are typically used in brackish water areas with flat land and moderate to high (1-2m) tidal ranges.

Pumped ponds can be set up in a variety of configurations with pumps used as primary or supplementary water supplier. Pumps increase availability and versatility of sites and may be utilised in perpetual flow or static ponds.

Static ponds may vary greatly in size and depth, depending on site characteristics, culture species and the intensity of the operation. As a general rule, static ponds are 0.1-2.0 ha in area and 1.0-2.0 m deep. Purpose-built aquaculture ponds may have a sloping bottom from 1.0 m draining to a harvesting sump 1.5-2.0 m deep. Such ponds may be filled and drained at the sump.

## **Pond preparation**

Eradication of predators, weed fishes and parasites: Predators in fish ponds such zooplanktons, insects, fishes, amphibians, reptiles, birds and mammals must be eradicated.

Eradication of aquatic vegetation and algae: Microphytes and macrophytes, submerged, floating or emergent can deplete nutrients and decreased production of plankton in fish pond.

Liming: Liming is a common practice in pond culture. There are three main purposes for liming ponds: 1) to increase the availability of nutrients, 2) to increase pH and to buffer against daily pH fluctuations. and 3) to sterilize ponds prior to stocking. While these practices use lime, they involve different compounds. The application of limestone (calcite or dolomite) to fish ponds with acid soils will increase the availability of nutrients, primarily phosphorous, to aquatic plants, specifically phytoplankton. Phytoplankton (microscopic free-floating plants) are the base of the food chain in fish ponds, and are essential for rapid fish growth and survival in recreational fish ponds and in commercial ponds in which small fish are being reared. Calcite and dolomite increase the total hardness, total alkalinity, pH, and act as a buffer to keep the pH constant. The rise in pH is primarily responsible for increasing the availability of phosphorous from the pond muds.

Identifying liming needs can be accomplished by taking either a water or soil sample from the pond. Measuring the total alkalinity of water in the pond is the most effective, and easiest way to determine if liming is necessary. Common application rates for limestone are 1 to 2 tons per surface acre. However, a more accurate rate can be calculated by taking a soil sample from the pond bottom and having a laboratory make a recommendation.

Limestone can be added anytime during the production cycle. Limestone will take several weeks to complete its impact on the water quality, so application should be at least one month prior to the initiation of a fertilization program. Limestone is best applied directly to the pond bottom prior to filling the pond with water. It should be spread evenly over the entire bottom. A disk harrow can be used to further incorporate the lime into the soil. Applying limestone to ponds which are full of water is more difficult, but can be done without fear of harming the fish. The material should be broadcast evenly over the entire pond surface.

Fertilization: fertilizers are used to stimulate beneficial phytoplankton production that acts as the basis of the food chain. By increasing the phytoplankton in a pond, more food items are available for smaller fish. This increases productivity, thereby increasing the amount of harvestable fish. The harvest of a fertilized pond can be triple that of an unfertilized pond. There are two types of fertilizer used in aquaculture.

**Organic fertilizer:** A fertilizer that is derived from animals, vegetable matters or minerals occurring in nature such as manure, compost or bonemeal.

The table lists nutrient content of a variety of organic matters as sources of organic fertilizers. As the C:N:P ratios in organic fertilizers often provide imbalanced nutrient ratio (N:P), it is recommended to supplement with inorganic fertilizer to make up desirable ratio.

Average elemental composition of organic manures (values are expressed as % by weight)

Manure	C:N ratio	% Moisture-free basis		
		N	P	K
<b>ANIMAL MANURES</b>				
Faeces/dung				
Buffalo	19	1.23	0.55	0.69
Cattle	19	1.91	0.56	1.40
Sheep	29	1.87	0.79	0.92
Goat & sheep (mixed)	-	1.50	0.72	1.38
Horse	24	2.33	0.83	1.31
Pig	13	2.80	1.36	1.18
Camel	-	1.51	0.15	1.30
Elephant	43	1.29	0.33	0.14
Tiger	10	2.82	3.19	0.03
Lion	9	3.60	3.21	0.04
Human	8	7.24	1.72	2.41
Poultry manure	9	3.77	1.39	1.76
Duck manure	10	2.15	1.13	1.15
Rabbit manure	-	1.72	1.30	1.08
Urine				
Buffalo	-	2.05	0.01	3.78
Cattle	-	9.74	0.05	7.78
Sheep	-	9.90	0.10	12.31
Goat & sheep (mixed)	-	9.64	0.14	-
Pig	-	10.88	1.25	17.86
Horse	-	13.20	0.02	10.90
Human	0.8	17.14	1.57	4.86
Meals				
Blood meal	3.5	11.12	0.66	-
Horn and hoof meal	-	12.37	1.60	-
Bone meal	8	3.36	10.81	-
Fish manure	4.5	7.50	2.82	0.80
<b>MANURES</b>				
Crop residues				
Wheat straw	105	0.49	0.11	1.06
Barley straw	110	0.47	0.13	1.01
Rice straw	105	0.58	0.10	1.38
Oats straw	-	0.46	0.11	0.97
Maize straw	55	0.59	0.31	1.31
Soybean straw	32	1.30	-	-
Cotton stalks and leaves	-	0.88	0.15	1.45
Cottonseed meal	-	7.05	0.90	1.16
Groundnut straw	19	0.59	-	-
Groundnut hulls	-	1.75	0.20	1.24
Groundnut shells	-	1.00	0.06	0.90
Bean straw	-	1.57	0.32	1.34
Cowpea stems	-	1.07	1.14	2.54
Cowpea roots	-	1.06	0.12	1.50

Coffee pulp	-	1.79	0.12	1.80
G Sugarcane trash	116	0.35	0.04	0.50
Grass	20	0.41	0.03	0.26
Green weeds	13	2.45	-	-
Oil palm bunch ash	-	-	1.71	32.50
Oil palm pressed fiber	-	1.24	0.10	0.36

#### Fertilizer Value of Farm Animal Manure

Animal	Unit weight of animal, lb,	Pounds/animal/year		
		N	P <sub>2</sub> O <sub>5</sub>	K
Dairy Cattle	1,000	131.4	36.1	55.8
Beef Cattle	1,000	170.8	26.3	39.4
Poultry	5	1.81	1.46	0.67
Swine	100	14.7	6.6	8.7
Sheep	100	12.3	4.3	8.9

Approximate conversion factors:  $P \times 2.3 = P_2O_5$ ,  $K \times 1.2 = K_2O$

#### Mineral Analysis (Percent of Total Solids)

Mineral	Hog feed	Hog manure	Beef cattle manure
Ca	.917	2.47	1.16
Mg	.194	1.20	0.47
Zn	.122	.05	0.01
Cu	.00218	.05	0.035
Fe..	.0161	.05	0.08
Mn	.00398	.02	0.01
Na	.312	.63	0.09
K	.682	3.49	2.28
P	.741	3.7	1.7
S	.455	...	...
N	2.839	...	...

Representative nitrogen (N) and phosphorus (P) concentrations (as dry wt) of different manures used for pond fertilization.

Manure	% N	% P	N : P ratio	Source
Chicken	2.8	1.4	2.0 : 1	AIT
Cow	1.5	0.6	2.5 : 1	GREEN et al. 1989
Duck	4.4	1.1	4.0 : 1	A.I.T. 1986
Buffalo	1.4	0.2	7.0 : 1	A.I.T. 1986

#### Chicken manure rate and Fish Production

Chicken manure (Kg/rai/wk)	Fish Production (Kg/5 month)
20	381
40	365
80	594
100	506

**Inorganic fertilizer:** A synthetic fertilizer containing a mixture of chemical compounds that are added to the soil to improve its fertility. Table below list a variety of fertilizer sources for N, P, K.

#### Approximate Grades of Common Commercial Fertilizers

Fertilizers	Percentage		
	N	P <sub>2</sub> O <sub>5</sub>	K <sub>2</sub> O
Urea	45	0	0
Calcium nitrate	15	0	0
Sodium nitrate	16	0	0
Ammonium nitrate	33-35	0	0
Ammonium sulfate	20-21	0	0
Superphosphate	0	18-20	0
Triple superphosphate	0	44-54	0
Monoammonium phosphate	11	48	0
Diammonium phosphate	18	48	0
Calciummetaphosphate	0	62-64	0
Potassium nitrate	13	0	44
Potassium sulfate	0	0	50

Percentage dissolution of phosphorus and nitrogen from selected fertilizers after settling through a 2- meter water column at 29°C

Fertilizers	Nutrient solubility (%)	
	Phosphorus	Nitrogen
Superphosphate	4.6	-
Triple superphosphate	5.1	-
Monoammonim phosphate	7.1	5.1
Diammonium phosphate	16.8	11.7
Sodium nitrate	-	61.7
Ammonium sulfate	-	85.9
Ammonium nitrate	-	98.8
Calcium nitrate	-	98.7

Factors affecting the action of fertilizers

1. Light and temperature: incident light level, water depth, turbidity.
2. Water exchange.
3. Water quality.
4. Substrate conditions and pond history.
5. Aquatic weed.
6. Phytoplankton composition.
7. Fertilizer solubility.
8. Fertilizer application method and frequency.
9. Zooplankton

**Inorganic fertilizer supplement to organic fertilizer:** As animal wastes often contain nitrogen and phosphorus concentrations that are not in balance as required for optimal phytoplankton production, it is necessary to supplement the manures with inorganic fertilizer source (N/P) to make the more desirable ingredients.



*Mechanical fertilizer application methods*

a) Underwater platform

The base of the platform should be 15-20 cm below the water surface, and located near the pond water inlet or at the end of the pond from which the prevailing wind comes. A single platform is sufficient for ponds up to 7 ha when plankton is grown. Suggested platform top sizes for ponds of different sizes are in the following table :

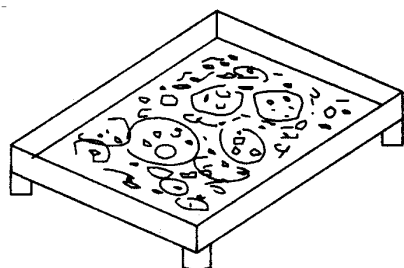

Pond area (ha)	Platform top dimensions (m)
1	0.85 X 0.85
2	1.25 x 1.25
3	1.50 X 1.50
4	1.70 x 1.70
5	1.90 X 1.90
6	2.10 x 2.10
7	2.25 x 2.25

b) Perforated floating can basket

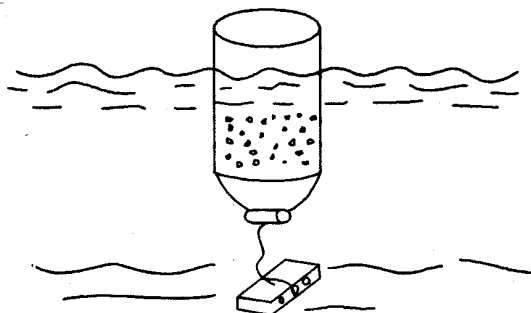

c) Suspended perforated sack

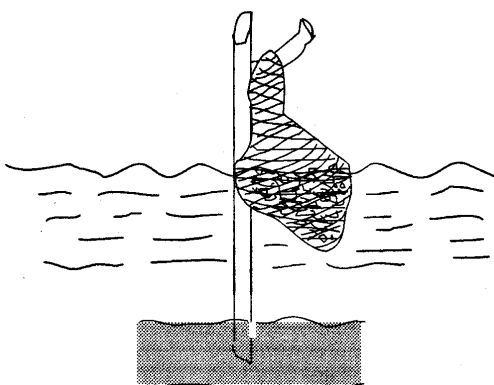

Fertilizer application rate and frequency:

As the complication relating to the effectiveness of fertilization discussed above, it is difficult to offer a set of quantitative formula for fertilization rate applicable to all situations. In general, to maintain a level of phytoplankton production at 20-40 cm. Secchi disc depth (80-300 mg chl-a / m<sup>3</sup>), the total P and N concentrations in the water column should be kept at a range of 0.2-0.5 mg P/L and 1-3 mg N/L, with a N:P ration of 5-10:1.

In principle, greater frequency of fertilization give greater stability of nutrient concentration level in water thus maintain even stable biological productivity.

In practice: twice a week to weekly application are adequate frequency.

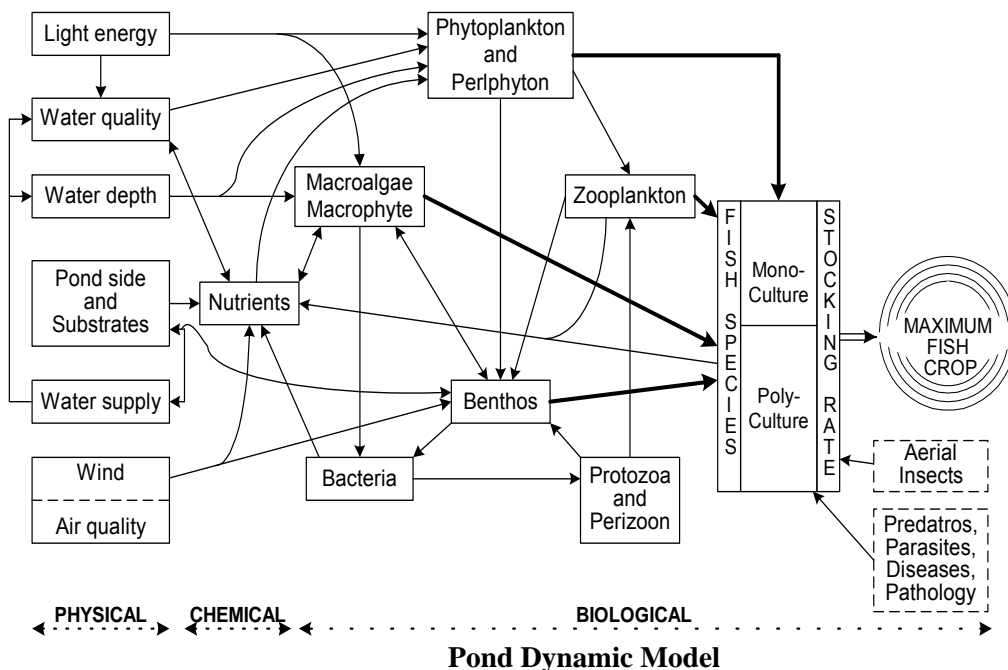

### Species selection

Although a large number of freshwater fish and crustacean species grow successfully in ponds, only a restricted number of species are usually cultivated on commercial scale. Reasons for this restricted choice is obvious. Commercial pond culture basically aims at achieving maximum possible rate of fish production and profit through optimum utilization of the natural food and the supplementary feed which drastically limits the choice of fish species for pond cultivation. Some of the basic criteria for selection are discussed below.

Criteria for selection of suitable fish species

1. Adaptability to pond environment
2. Faster growth rate
3. Efficient utilizers of natural food resources of the pond
4. Efficient converter of artificial feed
5. Hardy and not easily susceptible to disease
6. Non-predaceous, planktophagous and preferably herbivorous and detritus feeder
7. Compatibility with other cultivable species of fish
8. Palatable with high nutritive value
9. High market demand and high price.

Many species of fish are suitable for pond culture. Species which have been researched and successfully reared in earthen ponds are in following table:

Common name	Scientific name
Catfish	<i>Pangasius hypophthalmus</i> , <i>Pangasius conchophilus</i>
Striped catfish	<i>Pangasius sutchii</i>
Yellow catfish	<i>Pangasius bocourti</i>
River catfish	<i>Pangasius pangasius</i>
Sharp tooth catfish	<i>Clarias gariepinus</i>
Walking catfish	<i>Clarias macrocephalus</i>
Hybrid catfish	<i>C. gariepinus x C. macrocephalus</i>
Green catfish	<i>Mystus nemerus</i>
Nile tilapia	<i>Oreochromis niloticus</i>
Giant gourami	<i>Osphronemus gourami</i>
Striped snakehead	<i>Channa striatus</i>
Giant snakehead	<i>Channa micropeltes</i>
Climbing perch	<i>Anabas testudineus</i>
Sand goby	<i>Oxyleotris mamoratus</i>
Giant freshwater prawn	<i>Macrobrachium rosenbergii</i>
Common carp	<i>Cyprinus carpio</i>
Silver carp	<i>Hypophthalmichthys molitrix</i>
Grass carp	<i>Ctenopharyngodon idella</i>
Bighead carp	<i>Aristichthys nobilis</i>
Mud carp	<i>Cirrhinus molitorella</i>
Black carp	<i>Mylopharyngodon piceus</i>
Catla	<i>Catla catla</i>
Rohu	<i>Labeo rohita</i>
Mrigal	<i>Cirrhinus mrigala</i>

### Stocking density

Rates of stocking fry, fingerlings and yearlings is relation to food resources and condition of water body, carrying capacity of fish ponds and management practices.

The productivity of ponds in extensive pond culture depends upon the soil and water chemistry, location and water exchange. These factors limit the degree of primary productivity in the pond, and therefore the carrying capacity. In extensive systems, The stocking densities are low and yields are typically low and economics dictate that extensive pond culture is often not commercially viable.

In semi-intensive pond culture, production is increased through higher stocking densities, supplementary feeding and improved feed quality. In ponds, fish culture and primary production are correlated, so the fertilisation of ponds will increase fish production, particularly at the nursery stage. Fertilised ponds are commonly used for the nursery rearing of native warmwater fish. Organic and inorganic fertilisers may be used to increase the productivity in semi-intensive pond systems.

Intensive pond culture generally applies to pond systems where supplementary feeds, such as pelleted diets, are the primary source of feed for the growout of various species such as tilapia and catfish. Stocking densities in such systems are much greater than for semi-intensive systems, and often require additional energy input, such as mechanical aeration and/or high water exchange rates. Some examples of stocking density for pond culture are in the following table:

Species	Stocking density (fish/m <sup>2</sup> )	Remark
Nile tilapia ( <i>Oreochromis niloticus</i> )	250 (1-2 cm.) 3-5 (3-5 cm.)	Nursing (Earthen pond) Rearing (Earthen pond) (8-12 months)
Climbing perch ( <i>Anabas testudineus</i> )	20-50 (2-3 cm.)	Rearing (Earth pond) (3-4 months)
Hybrid catfish ( <i>C. gariepinus x C. macrocephalus</i> )	3,000-5,000 (3 days old) 300-500 (1 cm.) 40-100 (2-3 cm.)	Nursing (Concrete pond) Nursing (Earthen pond) Rearing (Earthen pond) (3-4 months)
Green catfish ( <i>Mytus nemurus</i> )	1,000-2,000 (3 days old) 60-90 (1.-1.5cm.) 1 (15-17 cm.)	Nursing (Concrete pond) Nursing (Earthen pond) Rearing (Earthen pond) (7 months)
Sand goby ( <i>Oxyleotris mamoratus</i> )	3,300 (3 days old) 100-160 (1 cm.) 60 (2.5 cm.)	Nursing (Concrete pond) Nursing (Concrete pond) Nursing (Earthen pond)
Giant freshwater prawn ( <i>Macrobrachium rosenbergii</i> )	30 (1-2 cm.) 10 (1-2 cm.)	Nursing (Earthen pond) Rearing (Earthen pond) (6 month-partial harvest)

### Types of fish-pond culture

- (a) Monoculture: culture of single species of: (i) same age and size; (ii) same sex (mono-sex culture), and; (iii) different size/age groups.
- (b) Polyculture: culturing of: (i) compatible combinations of different species of fishes, fishes and shrimps, fishes and crustaceans, fishes and molluscs; (ii) predator-forage combinations; determination of percentage of different species used in polyculture in relation to food resources of the pond and supplementary feeding facilities; possible polyculture combinations for Africa and combinations presently practised.

### CAGE CULTURE

Cage culture of fish utilizes existing water resources by encloses the fish in the cage or basket which allows water to pass freely. Today cage culture is receiving more attention by commercial producers. Factors such as increasing consumption of fish, some declining wild fish stocks have produced a strong interest in fish production in cages. Cage culture also offers the farmer a chance to utilize existing water resources which in most cases have only limited use for other purposes. Cage production can be more intensive in many ways than pond culture and should probably be considered as a commercial alternative only where open pond culture is not practical.

As with any production scheme cage culture of fish has advantages and disadvantages that should be considered carefully before cage production becomes the chosen method.

Advantages	Disadvantages
<ol style="list-style-type: none"> <li>1. Many types of water resources can be used, including lakes, reservoirs, ponds, strip pits, streams, and rivers which could otherwise not be harvested. (Specific state laws may restrict the use of public waters for fish production)</li> <li>2. A relatively low investment is all that is required in an existing water body</li> <li>3. Observation and sampling of fish is simplified.</li> <li>4. Allows the use of the pond for culture of other species.</li> <li>5. Harvesting is simplified.</li> </ol>	<ol style="list-style-type: none"> <li>1. Feed must be nutritionally complete and kept fresh</li> <li>2. Low dissolved oxygen syndrome is an ever present problem and may require mechanical aeration.</li> <li>3. The incidence of disease can be high and diseases may spread rapidly.</li> <li>4. Vandalism or poaching is a potential problem.</li> </ol>

Interest in cage culture has been revived as an alternative crop for farmers outside traditional fish farming areas and in areas with topography not conducive to levee ponds. As this interest continues to increase, more research into cage culture techniques and alternate species will no doubt occur. A great deal of variability exists in the research and commercial literature about suitable pond sizes, growing season, stocking densities, and size of fingerlings to stock. Stocking rates or densities are dependent on species, cage volume and mesh size, pond surface area, availability of aeration, and desired market size. In general, stocking densities are calculated on the number of kilograms of fish which can be reared per surface area of pond and per cubic meter of cage.

### Species selection

Many species of fish are suitable for cage culture. Species which have been researched and successfully reared in cages in Southeast Asia are in following table:

Common name	Scientific name
Catfish	<i>Pangasius hypophthalmus, Pangasius conchophilus</i>
Striped catfish	<i>Pangasius sutchii</i>
Yellow catfish	<i>Pangasius bocourti</i>
River catfish	<i>Pangasius pangasius</i>
Sharp tooth catfish	<i>Clarias gariepinus</i>
Walking catfish	<i>Clarias macrocephalus</i>
Hybrid catfish	<i>C. gariepinus x C. macrocephalus</i>
Green catfish	<i>Mystus nemurus</i>
Nile tilapia	<i>Oreochromis niloticus</i>
Giant gourami	<i>Osphronemus gourami</i>
Common carps	<i>Cyprinus carpio</i>
Striped snakehead	<i>Channa striatus</i>
Giant snakehead	<i>Channa micropeltes</i>
Sand goby	<i>Oxyleotris mamoratus</i>

Some examples of stocking density for cage culture are in following table:

Species	Stocking density (fish/m <sup>3</sup> )	Remark
Nile tilapia ( <i>Oreochromis niloticus</i> )	3,000 (1gm.)	Nursing (7-8 wks)
	2,500 (10 gm.)	Nursing (5-6 wks)
	1,500 (25-30 gm.)	Nursing (5-6 wks)
	1,000 (50-60 gm.)	Rearing
Green catfish ( <i>Mytus nemurus</i> )	50 (3 gm.)	Nursing (6 months)
	50-70 (200-250 gm.)	Rearing (4 months)
Sand goby ( <i>Oxyleotris mamoratus</i> )	70-100 (100-300 gm.)	Rearing (10-12 months)
Striped catfish ( <i>Pangasius sutchii</i> )	100-150 (100 gm.)	Rearing (10-12 months)
Yellow catfish ( <i>Pangasius bocourti</i> )	100-150 (100 gm.)	Rearing (10-12 months)
Striped snakehead ( <i>Channa striatus</i> )	30-40 (100 gm.)	Rearing (9-10 months)
Giant snakehead ( <i>Channa micropeltes</i> )	30-40 (100 gm.)	Rearing (9-10 months)
Giant gourami ( <i>Osphronemus gourami</i> )	1-2 (3 inches)	Rearing (8-12 months)

### Feeding practices for pond and cage culture

Fish must be fed with quality feed and adequate quantity for growth. Pond fish can be added by natural food in the pond while caged fish in most cases will receive no natural food and, therefore, must have a nutritionally complete diet which has adequate protein and energy levels, is balanced in amino acids and in essential fatty acids, and is supplemented with a complete array of vitamins and minerals. Many commercial feed mills manufacture both supplemental and complete diets. Fish should be fed a floating pelleted feed that allow the fish farmer the opportunity to observe the fish. In general, herbivorous and omnivorous species such as silver barb, carp and tilapia can be successfully reared from large-sized fingerlings on 16-25 percent protein complete diets. Catfish can be reared with 30-32 percent protein. Striped snakehead and carnivorous fish need diets with 38 to 42 percent protein. In semi-intensive systems, supplementary feed such as rice bran, broken rice can be applied.

Pellet sizes normally available include 1/8, 3/16, and 1/4-inch diameters. Usually large fingerlings can accept 1/4-inch pellets. Small fingerlings and species with small mouths may need to be started on 1/8-inch pellets. Fish will feed most aggressively near their preferred or optimum temperature and when oxygen levels are high. Oxygen is usually at acceptable levels (unless heavily overcast) between mid morning and late afternoon. From a temperature standpoint, warmwater fish such as catfish will feed better as the temperature rises in late afternoon in the spring, but prefer mid morning during the heat of the summer. Generally fish will adapt to any feeding time as long as it is consistent. Changes in the feeding schedule should be made gradually (e.g., not changing more than 30 minutes per day). Fish will grow faster and have better feed conversion if their daily feed ration is divided into two feedings given at least 6 hours apart. This is particularly true of small catfish, tilapia. For catfish, dusk feeding can increase growth and improve feed efficiency. Dusk is the natural feeding time for many species of fish. Dusk feeding cannot be practiced without a means of nighttime aeration. Dusk feeding can begin within 1 hour of sunset and can continue for an hour or more after sunset. The key to dusk feeding is not to overfeed. If mechanical aeration is not available, do not consider dusk feeding. Correctly feeding

the proper amount of feed is extremely important. Overfeeding wastes feed and money, and can cause water quality deterioration leading to stress and increased incidence of disease. Underfeeding reduces the growth rate, total production and profit. A general rule of thumb for most warmwater fish is to feed fish all they will eat in 10 to 30 minutes when the water temperature is above 22°C. Caged fish, particularly catfish, are sometimes shy and may not start feeding immediately. Also, when fish are first stocked into a cage they usually adjust slowly to feeding. Keeping good feeding records is essential to becoming a successful fish producer. It is a good practice to offer caged fish one-half of the amount of feed they consumed the previous day, so as not to overfeed if there is a weather, water quality or disease problem that reduces consumption. After adding feed observe the feeding response, adding more feed as needed at 20- to 30-minute intervals. If the fish have not consumed the feed after 20 to 30 minutes, do not add more feed. Many producers and researchers have found that catfish will continue to consume feed for several hours if fed at dusk. The key is to get as much feed into the fish as they want to eat (satiation) without leaving or wasting feed.

### **Feeding rate**

Feeding rates for fish are calculated on a percent of body weight per day basis, based on the fish size and water temperature. Small fish consume a larger percentage of their body weight than larger fish, and all fish increase consumption as water temperatures approach optimum temperature range. Small fingerlings will usually eat 4 to 5 percent of their consumed each day for the first week. A new estimate should be recalculated each week, based on estimated growth. Estimated growth is calculated by multiplying the total amount of feed fed during the week by the estimated feed conversion ratio (FCR) of 1.0/1.8. This estimated growth weight is added to the total weight at the beginning of the week. This new total weight is divided by the number of fish (less any deaths) to get a new weight of individual fish. After they reach advanced fingerling size the rate will decrease to 3 percent and nearing harvest size will drop to only 2 percent or less.

### **Guideline on feeds and feeding**

1. Observation of the fish at feeding time is vital. Feeding behavior is the best index of overall health. Actively feeding fish indicate everything is all right, for the moment. Poor feeding behavior should always be viewed with suspicion.
2. Reduce feeding levels when water temperatures drop below 20° or above 32°C.
3. Reduce or stop feeding on heavily overcast and windless days. These weather conditions reduce oxygen production and diffusion, particularly if sequential, and can lead to low dissolved oxygen. Feeding will only complicate the problem. Run aeration if available.
4. Feed quality must be excellent. Purchase feed which is known to be complete and keep it stored in a very dry, cool place. Feed should be fed within 90 days of the manufacture date.
5. Never feed moldy or discolored feed.
6. Keep accurate records on the amount of feed fed.

## **INTEGRATED AGRICULTURE-AQUACULTURE SYSTEM**

Integrated agriculture-aquaculture system is a combination of cultivation between fish with plants and/or terrestrial animals. The system diversification comes from integrating crops, vegetables, livestock, trees and fish imparts stability in production, efficiency in resource use and conservation of the environment. Uncertainty in markets and climate is countered by a wide array of enterprises. In integrated farming, wastes of one enterprise become inputs to another and, thus, optimize the use of resources and lessen pollution. Stability in many contrasting habitats permits diversity of genetic resources and survival of beneficial insects and other wildlife. Integrated agriculture-aquaculture offers special advantages over and above its role in waste recycling and its importance in encouraging better water management for agriculture and forestry. Fish are efficient converters of low-grade feed and wastes into high-value protein. Fish are the greatest sources of animal protein in rural Asia. For rural households, fish are small units of cash or food which can be

harvested more or less at will without loss of weight or condition. For sustainable development in farming, small-scale integrated agriculture-aquaculture is one option.

### **Rice-fish culture**

The rice-fish farming system is an old tradition practiced extensively in Southeast Asia in areas where is an floodplain and receives irrigated water.

#### ***Advantages***

- Provides additional food and income
- No additional expenses except when system is modified such as building trenches, strengthening dikes, etc.
- Optimises disused and under-utilized existing resources
- Maintains gene pool for locally valuable species

#### ***Constraints***

- Short growing season due to double cropping of rice
- Improper and excessive pesticide and herbicide use
- Uncontrolled flooding may result to fish loss
- Improper management/lack of human resources
- Low productivity and low-carrying capacity when no regular supplementary feed is provided
- Distance of sump pond from house

#### ***Preparation of field for rice-fish culture***

Good preparation is very important in order to succeed in rice-fish culture. Every farmer must be able to: hold enough water over a large enough area for enough time to produce enough fish; and prevent serious flooding of the dikes and other boundaries of his rice field.

Having a satisfactory water situation in the field is a key factor in the technology; this cannot be achieved if preparation is poor.

#### ***Field size and shape***

There are many factors that should be considered:

1. How much land does the farmer own? If the farmer does not own the land and the landlord is agreeable, how big an area does the landlord want to try?
2. Topography and slope will greatly affect field size and shape. It may be possible to construct a large, square field on very flat land, but not quite so in sloping areas.
3. What area does the farmer think is suitable? This can limit field size and affect field shape.
4. How large an area does the family feel comfortable with trying out (especially for beginners)?
5. How large an area does the family think it can prepare and manage ?

Some people say that a square field of 0.5-1 ha is the best size for rice fish culture. However, operations larger or smaller than this size can also be very successful. Good preparation and good management are the keys to success, whatever the size.

#### ***Dikes***

All dikes must be built safely higher than maximum flood levels. During construction, the dike should be raised high enough to allow for compaction and erosion.

In raising the dikes, an excavation usually results. This may as well occur inside the field, all other factors being equal. This way, a small pond or trench is formed, which serves as a refuge for the fish.



## Refuges



A refuge is a pond, trench or low point in the rice-fish field. When the rest of the field is dry, fish can be held here. Under some conditions (see paper on fry nursing in rice-fish systems, this volume), the refuge may be stocked before rice is transplanted.

Having a refuge is usually advisable and may be necessary for success. Without it, fish have to be harvested before the field dries out or moved to a pond in a flooded area. A refuge of at least 50 cm depth is desirable. If the farmer wants to hold fish all year around, the refuge will probably have to be much deeper than this. A refuge, when dug, is usually made at the lowest part of the field so that water and fish can easily collect there.

Some other factors governing size and arrangement of refuges:

1. How much rice-growing area is the family willing to sacrifice for the refuge? This may depend on their total rice-growing area or on the relative importance they give to rice and fish.
2. How much money or time and labor can the family invests? As with field size, this can be an important limit.
3. What kind of soil is involved? A narrow trench (say 1 m wide x 1 m deep) will fill in quickly in sandy soil, but may last well in clay. The refuge in sandy soil should be three or more times wider than its depth.
4. Topography will affect trench or pond configuration. Extensive peripheral trenches on sloping areas will occupy too much space since such a field will be narrow.

## Drains

Usually, the field will need a drain so that excess water can be removed rapidly without eroding the dike. Inflow and especially outflow drains are advisable. Drains should be screened to prevent fish from escaping.

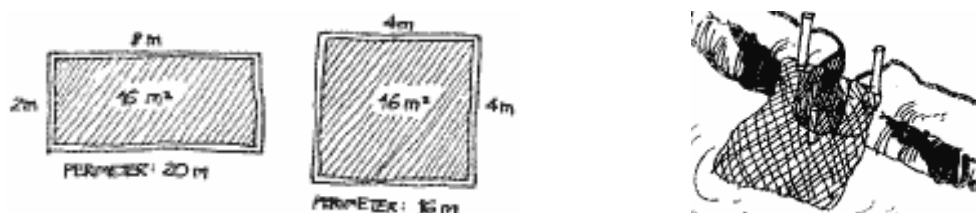

A bamboo, hollow log or pipe can be used, depending on availability. A screen should be placed at the point where the water enters. The screen can be a piece of fine netting or of flat metal full of nail holes. A little gravel scattered under the pipe will reduce dike erosion.

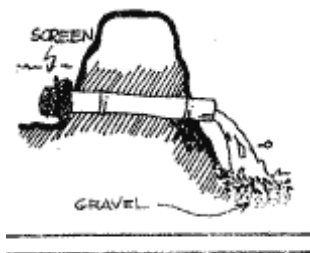

Such a drain is best for small fields (less than 1 000 m<sup>2</sup>) with limited flow (especially fields used to nurse hatchlings or small fry). Screens need to be checked every few hours for clogging any time water rises to pipe level and this can be a nuisance.

In most fields, the drain consists of a simple breach in the dike. This is screened by thin splints of bamboo or similar material, bound or nailed together.



Farmers in the rainier parts of northeast Thailand often use a bamboo chute or PVC pipe, set at a breach in the dike at the lowest part of the ricefield.

The bamboo or pipe slopes up slightly and narrows. Below the narrow end, a jug-shaped basket or net bag is set. Hence, water runs out along the length at the li, but ultimately falls into a bag or basket which holds any fish washed out of the field. These can be eaten, sold or returned to the field for further growth.

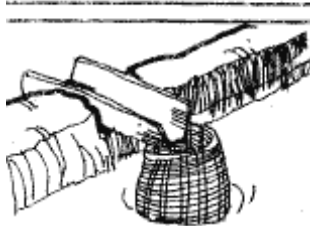

Some farmers use a simpler version, by setting a net bag supported by sticks next to the outlet drain.

The drain should be set in the dike somewhere between depth of water that is best for the rice in the field and the depth that it will tolerate. A small pipe does not drain a large field effectively. The farmer will have to make a guess as to how wide the drain should be, based on experience. It is better to have the drain a little too wide than too narrow.

### Farm layout of rice-fish farming

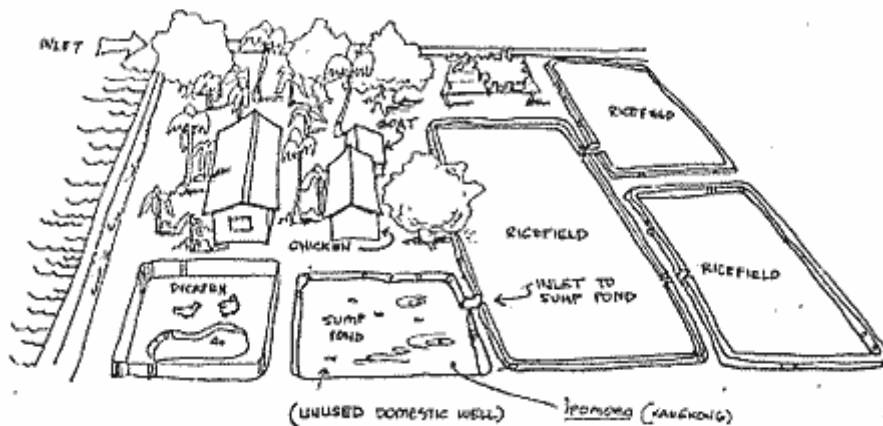

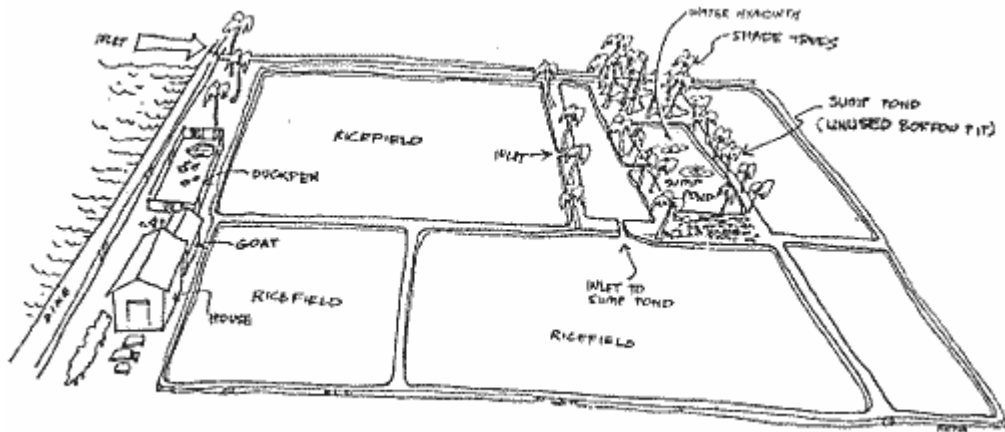

Material flow on a rice-fish farm system

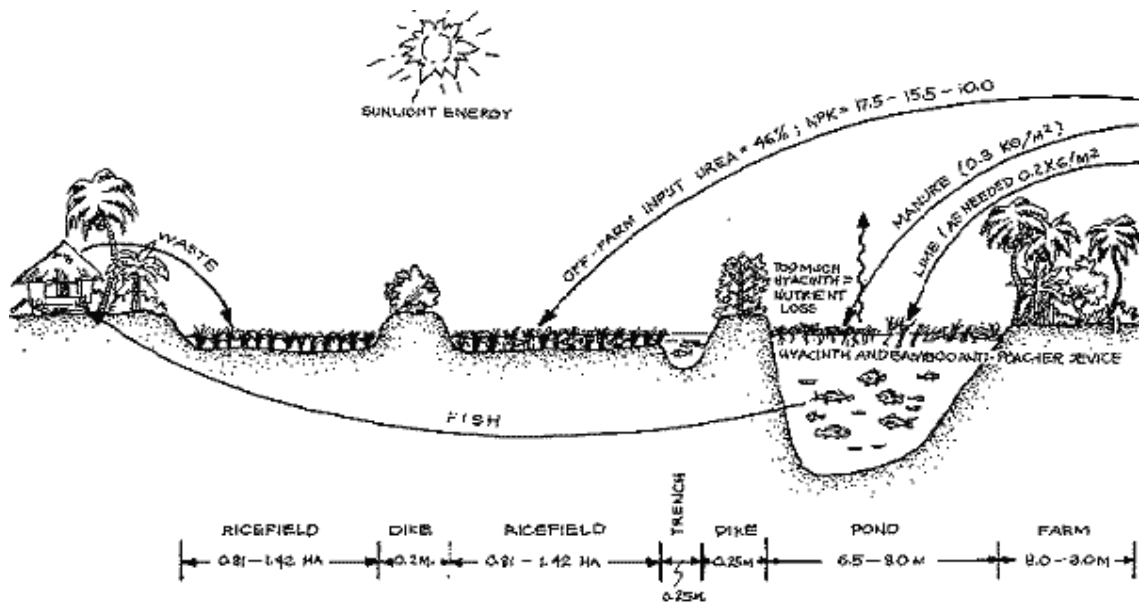
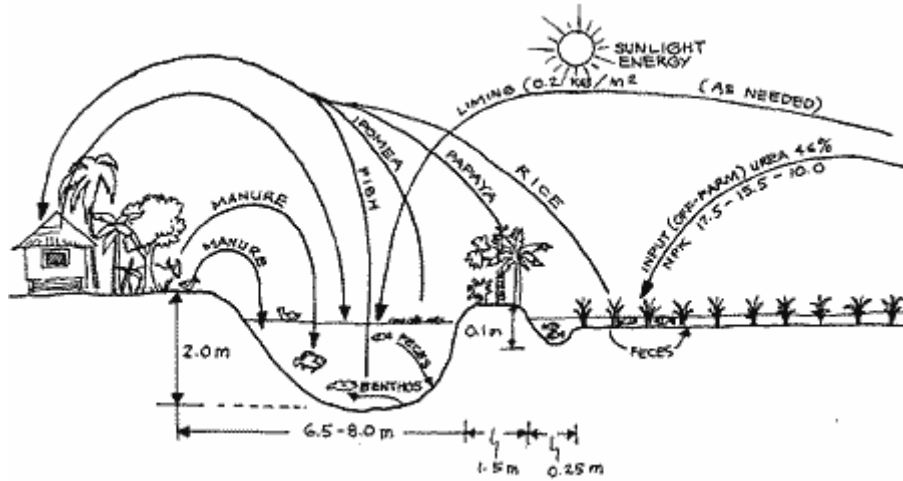

### **Species for rice-fish culture**

Local species and some exotic species can grow well in ricefields. They have adapted to shallow water, high turbidity and temperature, and low dissolved oxygen conditions of the fields.

- The snakeskin gourami (*Trichogaster pectoralis*) is numerically the most important. This species and the three-spot gourami (*T. trichopterus*) are herbivore/planktivore and occupy the lower rung in the food chain.
- Climbing perch (*Anabas testudineus*) is an insectivore.
- The catfish (*Clarias macrocephalus*), an omnivore, and the mudfish or snakehead (*Channa striatus*), a carnivore, are also important species.
- Tilapia (*Oreochromis spp.*), a herbivore/planktivore/insectivore, is ecologically suitable and economically important.
- Another species to be considered is the freshwater prawn (*Macrobrachium rosenbergii*).

### **Fish stocking**

The following guidelines apply in any case where seed fish are transported and stocked:

- Transport and stocking are best done early in the morning or failing this, late in the day when temperatures are lower.
- Fish, once purchased, should be transported promptly and kept out of direct sunlight.
- They should not be shaken up or unduly disturbed.
- On arrival at the pond or ricefield, bags should be set in the water (where the fish will be released) for several minutes until temperatures become the same inside and outside the bags.
- Bags should only then be opened and fish immediately allowed to swim into their new home of their own accord.

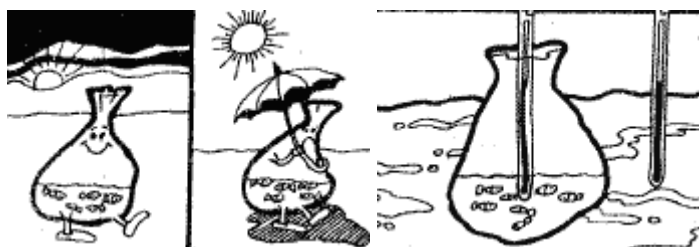

### **Timing**

The earlier in the season that fish can be stocked, the longer the growing period. Also, the earlier in the rainy season, the fewer the predators. However, fish cannot be stocked before there is water available and the farmer should be reasonably sure that the field will hold water for several months before he stocks. Rice should also be well-established with 2-3 tillers out before fingerlings or large fish are allowed into the field. Finally, the farmer may be ready to stock but seedfish may not be available. Therefore, the family may have to wait until fish can be found.

The wide scale of rice-fish is still constrained by continued application of pesticides in rice-based farming. The use of pesticide is not recommended in rice-fish farming. In rice-fish culture, there are ways of controlling rice pests that do not need pesticide, such as:

- Quick submergence (for three hours) of rice plants in water. This makes the insects vulnerable to fish predation. Limitation: suitable only before plants are taller than the dikes.
- Two persons can drag a stretched rope (50-100 m) across the rice fields to knock off the insects into floodwater, after which they can be eaten by the fish. Limitation: suitable only before rice plants reach booting stage.

However, should a farmer insist on using pesticides, here are some helpful tips:

1. Considerations in applying pesticides:

- Choose and apply properly pesticides that have low toxicity to fish.
- Minimize the amount of pesticide getting mixed with water.
- Apply at suitable time.

2. Considerations in preventing fish poisoning:

- Drive the fish into the sump, draining the field slowly before spraying. Keep the fish in the sump until the toxicity in the sprayed field is gone.
- Increase water depth (+10 cm) to dilute the concentration of pesticides in the water.
- Flush water through the ricefield. Open the inlet and outlet of the field, and allow irrigation water to flow freely during spraying. Begin spraying from the outlet end of the field. When one-half of the field is already sprayed, stop for a while and allow the pesticides to flow out of the field. Then, continue spraying towards the inlet end of the field until it is finished.

It is best to wait until the rice is well established before releasing seed fish, particularly if the fish are large. Fish can be stocked once two or three tillers have appeared for which the usual waiting period is 1-3 weeks after transplanting or 4-6 weeks after direct seeding depending on the state of the rice and the size of the fish. Small fry (about 2.5 cm long) can be stocked immediately after transplanting, without harm to the rice. The authors have never seen a rice variety that does not work with fish, but some varieties are better than others. Deepwater-tolerant varieties are preferable to those which thrive in only very shallow water. In some areas where rainfalls are highly unpredictable, farmers prefer to wait until very late in the rainy season to stock fish. At this time, surface water accumulation will be at its yearly peak and the chance of flooding from later rains is very slim. In such cases, long-lived, late-maturing rice varieties are best. Rice varieties which tiller (i.e. produce new plant stems) rapidly or under a wide range of water conditions will allow farmers to stock earlier in many cases.

Yields seem the most enhanced on farms with poor soil where fish are fed intensively. Possible mechanisms include:

- increasing availability of nutrients for increased floodwater productivity and uptake by rice; and
- reducing loss of ammonia through volatilization after fertilizer application by preventing floodwater pH to rise over 8.5.

**Stocking density**

- Stocking can be done before or during land preparation in the pond refuge; or 7-10 days after transplanting, if fish are released directly to the fields. If stocked in the pond refuge, animal manure should be applied into the refuge 4-5 days before fish stocking. About 15 kg may be applied in a 100 m<sup>2</sup> pond refuge.
- The stocking rate, using either monoculture of Nile tilapia or polyculture of Nile tilapia and common carp (5 cm.) is 400-800 fish/1,600 m<sup>2</sup>. For polyculture, the stocking ratio of Nile tilapia to common carp is 1:1, or common carp (*Cyprinus carpio*), silver barb (*Barbodes gonionotus*) and tilapia (*Oreochromis niloticus*) at 2:1:1. or common carp (*Cyprinus carpio*), silver barb (*Barbodes gonionotus*) and tilapia (*Oreochromis niloticus*) 500 and Chinese and Indian major carp 30-50 fish/1,600 m<sup>2</sup>.
- Ten days after transplanting, fish stocked in the pond refuge may be released to the field by making openings in the dividing dike. Fish will graze on natural food available in the ricefield.

### Supplemental feeding

- This feeding is recommended at the middle culture period of rice, during which production of natural food in the fieldwater declines due to shading of rice leaves.
- Feeds: rice bran, kitchen refuse, termite, etc. Animal manure may also be applied in the pond refuge.
- Feeding rate: 3-5 percent of fish biomass

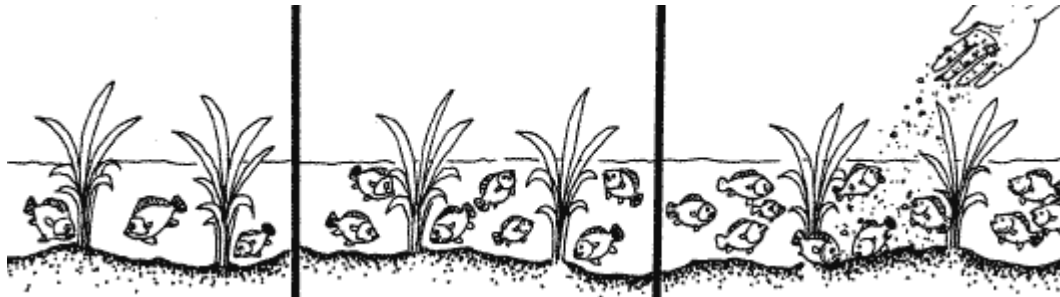

If stocking density is low, there is often sufficient natural food in the paddy and no feeding is necessary.

If stocking density is increased, natural food in the paddy is not enough and production is low.

If stocking density is increased, maximum production can still be obtained with supplementary feeding.

### Harvesting

- Harvest fish by draining the water very slowly 1 week before rice harvest to avoid trapping the fish in the middle of the field.
- Select large fish for consumption or disposal and confine the small fish (50 g) for next culture.
- After harvesting rice, the field is immediately reflooded to about 30 cm deep, and the small fish in the refuge are released to allow them to grow for another 60 days before the dry season crop.

### Pig-fish culture

Integrated pig-fish culture is not a new concept; it has been practiced for many years in many parts of Asia. Raising pigs and fish at the same time has several advantages:

- Fish farmers can produce fish without feeding and hauling manure to fertilize the pond.
- Pig-fish culture maximizes land use by integrating two farm enterprises in the same area.
- The fishpond serves as a sanitary disposal place for animal wastes.
- Backyard integrated pig-fish culture provides additional income and a cheap source of animal protein for the family.

### Location of the pig pen

- There are two optional designs for locating the pig pen. It can be constructed on the dikes near the fishpond. Preferably, the floor should be made of concrete (or other impermeable material to catch pig manure and urine) and should slope toward the pond. A pipe is necessary to convey the manure and urine into the pond. An alternative design is to construct the pig pen over the pond. In this case, the floor can be made of bamboo slats spaced just enough to allow manure and urine to fall directly into the pond but not too wide for the feet of the pigs to slip into (thus, causing injuries). The pen should have a floor area of 1 m x 1.5 m for each pig. Establish the pond near a water source. However, the site should be free from flooding. Inlet and outlet pipes should be installed and screened.
- The water depth should be maintained at 60-100 cm. With this recommended pond area and water depth together with the right stocking density, problems of organic pollution are avoided.
- A diversion canal can be constructed to channel excess manure into a compost pit or when manure loading needs to be stopped.

- Nutrient-rich water from the pond can be used for vegetables grown on the pond dike or adjacent to the pond.

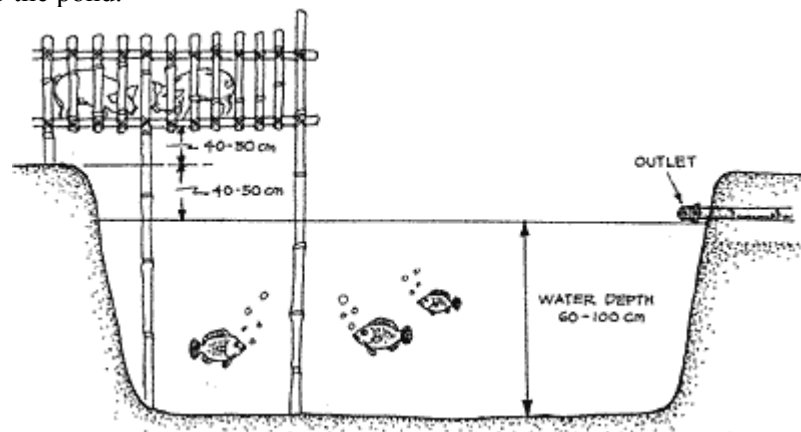

### Stocking

- One pig can sufficiently fertilize a 100-150 m<sup>2</sup> pond with its manure.
- Stock the pond with tilapia or catfish fingerlings (3-5 cm.) at stocking density 200 fish/100 m<sup>2</sup>
- Stock the pig pen with one weanling (8-10 kg or 1.5 month old).
- Fish and piglets can be stocked at the same time.

### Pig feeding

- Feed the pigs twice a day by mixed rice bran, broken rice, fish meal and pellet feed. Supplemental feeds such as Ipomoea (*Ipomoea aquatica*) may be given.

The raising of pigs can fruit-fully be combined with fish culture by constructing animal housing units on the pond embankment or over the pond in such a way that the wastes are directly drained into the pond. The system has obvious advantages:

- The pig dung acts as excellent pond fertilizer and raises the biological productivity of the pond and consequently increases fish production.
- Some of the fishes feed directly on the pig excrete which contains 70 percent digestible food for the fish.
- No supplementary feed is required for the fish culture, which normally accounts for 60 percent of the total input cost in conventional fish culture.
- The pond dikes provide space for erection of animal housing units.
- Pond water is used for cleaning the pigsties and for bathing the pigs.
- The system cannot be adopted in all parts of India due to religious consideration but it has special significance in certain areas as it can improve the socioeconomic status of weaker rural communities, especially the tribals who traditionally raise pigs and can take up fish-pig farming easily.

Design 1: Pig pen on pond dike

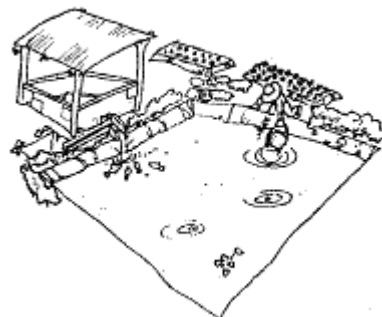

Design 2: Pig pen over pond area

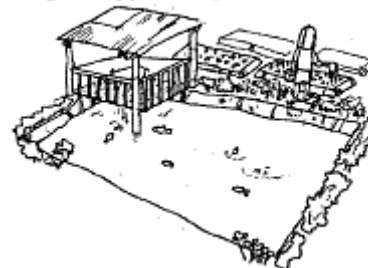

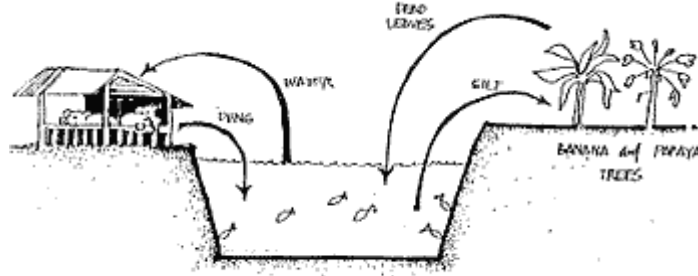
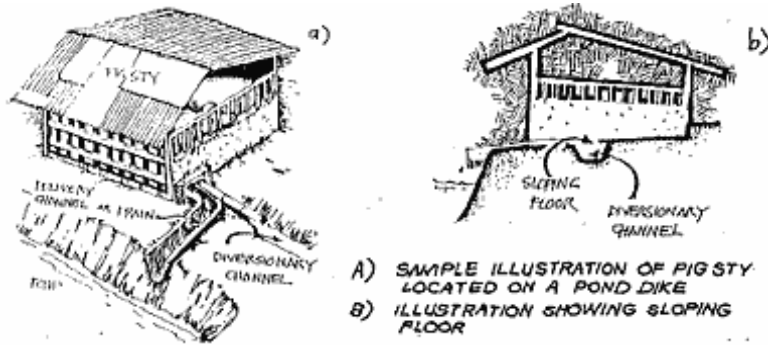

FISH-PIG FARMING MATERIAL FLOW

*Fish-pig farming material flow*

**Harvesting**

- Harvest the fish after 4-5 months. Collect fingerlings (if present) for the next growing season; sell the surplus. Partial harvesting for family consumption can also be done as needed.
- Sell the pig after 4-5 months.
- If possible, scrape out the organic waste or mud on the pond floor and use as fertilizer for the vegetable crop.

**Limitations**

- High cost of inputs for pig growing (feeds and weanlings)
- Consumers may be reluctant to eat fish produced in manure- loaded ponds, creating potential marketing problems.
- Farmers want their animals close to their homes (because of theft problems) and this may not be always possible.

**Possible solutions to overcome some of the limitations**

1. Raise crossbred/native pigs to reduce feed cost.
2. Occasionally, fish from ponds, which were overloaded with manure, can have a «muddy» or off-flavour taste which can be removed through the following measures:
  - Stop loading manure to the pond a few days before harvesting fish.
  - Transfer harvested fish to a net enclosure installed in a clear pond at least 4-6 hours (better several days) prior to selling or eating them.

**Chicken-fish culture**

Chicken raising for meat (broilers) or eggs (layers) can be integrated with fish culture to reduce costs on fertilizers and feeds in fish culture and maximize benefits. Chicken can be raised over or adjacent to the ponds and the poultry excreta recycled to fertilize the fishponds. Raising chickens over the pond has certain advantages: it maximizes the use of space; saves labour in transporting manure to the ponds and the poultry house is more hygienic. No significant differences have been observed on the chickens' growth or egg laying when they are raised over the ponds or on land. In case of the former, the pond embankment could still be utilized for raising vegetables.



### **Stocking**

- Stock broilers 1000 or chickens layers at density of 200 chickens/1,600 m<sup>2</sup> and fingerlings of Indian carps, catla (*Catla catla*), rohu (*Labeo rohita*), mrigal (*Cirrhinus mrigala*) and Chinese carps, silver carp (*Hypophthalmichthys molitrix*), grass carp (*Ctenopharyngodon idella*) and common carp (*Cyprinus carpio*). Species stocking rate could be 40 percent surface feeders (catla and silver carp), 20 percent rohu, 30 percent bottom feeders (mrigal and common carp) and 10 percent grass carp or Nile tilapia at density of 3,000 fish/1,600 m<sup>2</sup>.

### **Feeding**

- No feeds need to be given, as the feed spilled by chicken (which could be as much as 10 percent) fall into ponds.

### **Fertilization**

- No fertilizer is needed, except for excreta of chicken falling into ponds.

### **Harvesting**

- Harvesting of fish could start 6-7 months after stocking when some fish reach table size.

### **Oxygen depletion**

- When water becomes deep green due to plankton blooms, oxygen in the water may get depleted and fish may die. In such cases, put mats or plastic sheets below the poultry house to catch the chicken excreta and suspend nutrient inputs for 1 to 3 weeks. If possible, immediately irrigate the pond with freshwater.

### **Vaccinate your chickens**

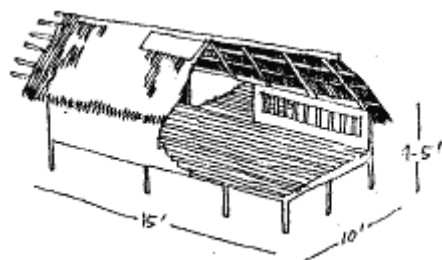

In some countries, vaccines can be obtained from the nearest livestock office, free of cost. The following are some reminders when collecting vaccines:

- Bring a good thermoflask and a little cotton wool.
- Do not waste vaccine. Obtain only the exact amount needed. Vaccine production costs a lot to the government.
- Store vaccines at low temperature, preferably in a refrigerator, to maintain their effectiveness.





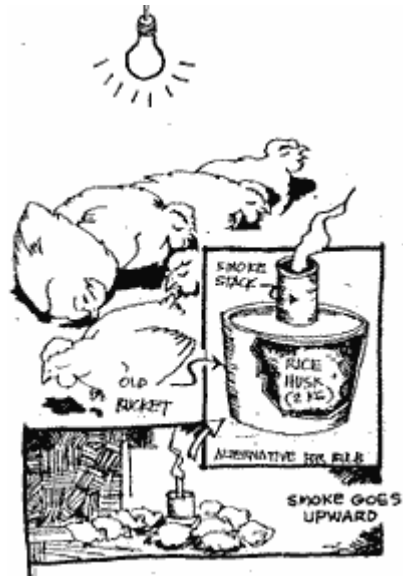

### **Equipment necessary in vaccination**

- Thermoflask of sufficient capacity to carry the vaccines.
- Nylon syringe - one or two, graduated at 1 ml intervals. Smaller-capacity syringe is preferable.
- Needles of gauge 20 or 21 and 14 or 15. Shorter needles of 1-2 cm length are preferable for poultry vaccination. A few large sewing needles are suitably modified for fowl pox vaccination.
- Measuring cylinder
- Two wide-mouth bottles: one to carry distilled water and another to dilute vaccines, when necessary. These items preferably should be of nylon or polypropylene which could be sterilized by boiling when necessary.

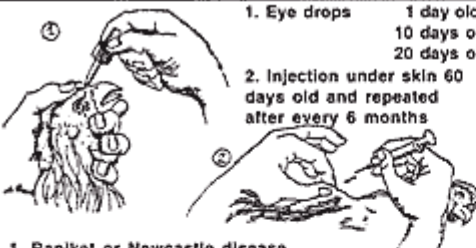
### **Reminders when vaccinating chickens**

- Sterilize syringes, needles and all other equipment before using.
- Put ice cubes at the bottom of the thermoflask and a layer of cotton wool before placing the vaccine vial. Close the flask.
- Check vaccine if it looks all right. Do not use discolored or unusual-looking vaccines.
- Use distilled water purchased from a pharmacy when diluting vaccines, or boil clean water for 10-15 minutes. Cool down, then strain into a clean bottle.
- When only a small amount of distilled water has to be added, draw the required amount into the sterile syringe and inject into the vial. Dissolve by vigorously shaking the vial.
- Pour the balanced amount of distilled water into the mixing bottle. Draw the dissolved vaccine into the syringe. Pour into the mixing bottle containing the balanced quantity of distilled water. Thoroughly mix with a sterilized rod.
- In case of fowl pox, remove the required amount into a sterilized empty vial and use for vaccination. This prevents contamination and subsequent waste of surplus vaccine.
- Do not spill vaccines. This could be fatal to chickens.
- Hold the needle with the knob. Do not touch the tip when assembling the syringe for vaccination. Contaminated needles should not be used until sterilized.
- Before vaccination, confine the birds, picking up one by one and releasing after vaccination. This makes vaccination easy and no bird is missed.
- Do not vaccinate birds suffering from disease or in a state of stress. Vaccinate them only when they are back to normal.
- Two vaccines should not be given the same day. A 10-day gap is needed between two successive vaccinations.
- Record data so that the next vaccination will be known.
- If leftover diluted vaccine can be used within a short period, it should be put in a clean polythene bag and placed in the flask containing ice.
- Wash all equipment used with soap and clean water, then sterilize in boiling water.
- Thoroughly clean empty vaccine vials. Return them to the Livestock Officer when collecting the next requirement of vaccines.
- Vaccinate birds on time.



Vaccination technique	Medical dosage	Consequences if you do not vaccinate
<p>1. Eye drops 1 day old 10 days old 20 days old</p> <p>2. Injection under skin 60 days old and repeated after every 6 months</p>  <p>1. Raniket or Newcastle disease</p>	<p>BCRDV</p> <p>1 drop into the eye</p> <p>RDV</p> <p>1 ml into the thigh</p>	<p>Show difficulty in breathing, unusual gait, moving in circles, walking in backward direction, head hidden between legs.</p> 
<p>Pricking under wing bed 30 days old and repeated after every 6 months.</p>  <p>2. Fowl pox</p>	<p>FP Vaccine</p> <p>1 ml</p>	<p>LESIONS</p> <p>Pox lesions - small vesicles in the face comb and wattles</p> 
 <p>3. Fowl cholera</p> <p>Injection under skin 90 days old and repeated after every six months</p>	<p>1 ml</p>	 <p>Birds suffer from diarrhea and faeces is yellowish or greenish. The birds become droopy and sleepy; head will be drawn down or turned backward resting on the wing. Breathing is difficult.</p>

### Duck-fish culture

Raising ducks over fishponds fits very well with the fish polyculture system, as the ducks are highly compatible with cultivated fishes. The system is advantageous to farmers in many ways:

1. Ducks fertilize the pond by their droppings when given free range over the pond surface. Ducks have been termed as manuring machines for their efficient and labour-saving method of pond manuring, resulting in complete savings on pond fertilizer and supplementary fish feed which accounts for 60 percent of the total cost in conventional fish culture.
2. Ducks keep water plants in check.
3. Ducks loosen the pond bottom with their dabbling and help in release of nutrients from the soil, which increase pond productivity.
4. Ducks aerate the water while swimming; thus, they have been called «biological aerators.»
5. Duck houses are constructed on pond dikes; hence, no additional land is required for duckery activities.
6. Ducks get most of their total feed requirements from the pond in the form of aquatic weeds, insects, larvae, earthworms, etc. They need very little feed, and farmers normally give kitchen wastes, molasses and rice bran, for the purpose.

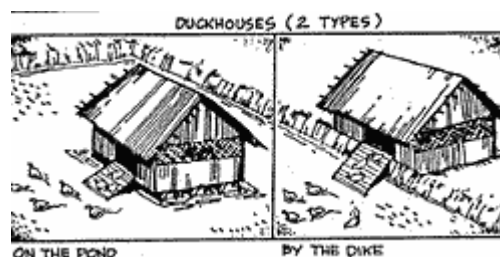

### Cultural practices

Successful pond management is the basis of profitable fish culture. Build the pond (about 1 000 m<sup>2</sup>) near your house to enable you to take proper care of your ducks and fish and to discourage poaching.

Check the pond dikes and repair the damages, if any. Deepen the pond so that it retains more than 1 m depth during the dry season.

Drain or dry the pond and remove or kill all the remaining fish stock from the pond by applying 15 kg bleaching powder and 15 kg urea/1 000 m<sup>2</sup>.

Urea and bleaching powder may be applied one after the other and the dead fish netted out. Alternatively, 250 kg of Mahua oil cake (*Basia latifolia*) may be applied which not only kills fish but also acts as pond fertilizer.

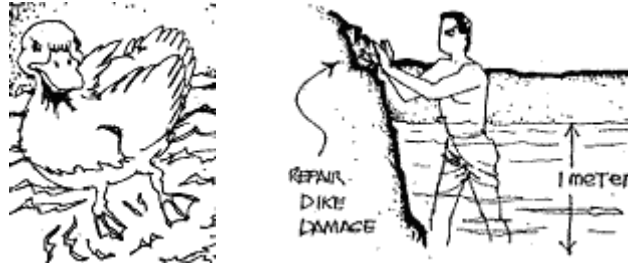

Apply 20-25 kg of lime about a week before manuring the pond. In case a mixture of bleaching powder and urea is applied to eradicate the predatory and weed fishes, apply only 5-10 kg of lime (reducing the amount of bleaching powder applied). Manure the pond with a basal dose of cattle dung at 500 kg/1 000 m<sup>2</sup>.

**Stocking density**

Stock the pond with fingerlings (5-7 cm. or large enough escaping from duck) 7 days after poisoning as the toxicity of bleaching powder lasts for about 1 week. The stocking density is 3,000 fish/1,600 m<sup>2</sup>. Some alterations can be made on the stocking density and species ratio depending upon the pond conditions and availability of fish seed.



*Fish-duck farming material flow*

**Harvesting**

Fish which attain marketable size should be harvested and the rest allowed to grow further. Final harvesting may be done 10-12 months after stocking.

**Duck farming**

Egg laying by ducks depends upon many factors, including breed and strain, but good management contributes considerably towards the achievement of optimum egg-flesh production.

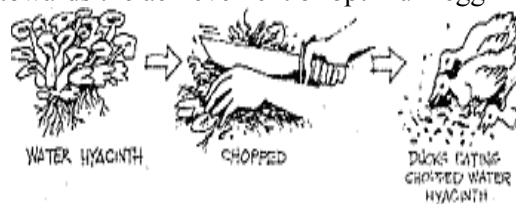

The ducks do not need elaborate housing since they remain in the pond most of the day. A low-cost night shaker made of bamboo or any other cheap material should be available in the area either on the pond embankment or on the water surface. The house should be well-ventilated and so designed that the washings are drained into the pond.

The ducks can find natural food from the pond. They will need very little supplementary feed which can come from household wastes, such as kitchen leftovers, rice bran, broken rice and spoiled cereals, if any. Alternatively, a balanced feed may be purchased and given at 50 g/bird/day.

Moldy feed, or feed kept for long time, should be avoided as molds contain toxins which may cause poisoning.

The ducks start laying at the age of 24 weeks. Laying boxes with straw may be kept in the duck house.

Proper sanitation and health care are very important to maintain a healthy stock. A sick bird is easy to detect: it becomes restless, its eyes lack brightness, and watery discharge comes out of the eyes and nostrils. The sick bird should immediately be isolated and treated.

The eggs are collected every morning as the ducks lay eggs only at night. The ducks lay eggs for two years, after which they should be culled.



**FRESHWATER AQUACULTURE TECHNIQUES  
FOR RURAL DEVELOPMENT**

**Principles of Fish Health Management:  
Fish Diseases, Disease Prevention and Control**

**SUBJECT PLAN**

<b>Subject</b>	Principles of Fish Health Management: Fish Diseases, Disease Prevention and Control
<b>Date/Time</b>	5 July 2007, 10.30-12.00 hrs and 13.00-15.00 hrs
<b>Officer-in-charge</b>	Mr. Bunchong Chumnongsittathum
<b>Objectives</b>	After the subject, The participants will be able to: 1. Know the principles of disease outbreak and how to preventing the disease. 2. How to recognize and the disease. 3. Apply the prevention and control of the disease. 4. The principle of disease treatment.
<b>Topics</b>	1. Cause of Disease Outbreak 2. Types of Disease 3. Environmental Stress 4. Clinical sign 5. Disease Control 6. Treatment 7. Disease Prevention
<b>Detailed Activity</b>	
<b>Time</b>	<b>Sub-activity</b>
<b>5 July 2007</b>	
<b>10.30-12.00</b>	<b>Principles of Fish Health Management: Fish Diseases, Disease Prevention and Control</b> Introduce on the cause of disease outbreak and the relationship among the host, disease and the environment. Explain briefly on the types of disease and its clinical sign.
<b>13.00-15.00</b>	<b>Principles of Fish Health Management: Fish Diseases, Disease Prevention and Control (continue)</b> Explain on the control, treatment and disease prevention concept. This also includes the examples of the treatment and caution of each chemotherapy.

## PRINCIPLES OF FISH HEALTH MANAGEMENT: FISH DISEASES, DISEASE PREVENTION AND CONTROL

*Bunchong Chumnongsittathum  
Tak Inland Fisheries and Development Center,  
Department of Fisheries, Thailand*

Fishes, like the other animals, are subject to a wide spectrum of diseases. Diseases of fishes require a somewhat different approach to problem solving than diseases involving terrestrial animals. Aquatic animals are in an entirely different environment than the air-breathing animals. Fishes are poikilothermic, and their internal biological systems are tremendously altered by water temperature. Their internal and external biology is also altered by the other physical factors of the environment: pH, osmotic pressure, dissolve gas, ions or elements and others. These factors also determine if an etiological agent (disease-causing agent) can and will cause disease among fishes. Therefore, the fish disease diagnostician must have a broad knowledge of aquatic environment in order to relate clinical findings to disease entities.

Most of the study and report on disease outbreaks were related to fishes from culture systems because of the high stocking density of cultured fish which quite different from the natural environment. The uses of supplementary feed in aquaculture are mostly leading to organic loads in the culture system which might alter water quality making the opportunity on disease outbreak.

### CAUSE OF DISEASE OUTBREAK

The occurrences of diseases in fishes are like the other animals, however, the other 3 things are required for disease outbreak more than the *receiving* of pathogens. Snieszko (1974) has described the relationship of host, pathogen and environment as followings:

1. Host susceptibility.
2. Pathogen virulence.
3. Environmental stress.

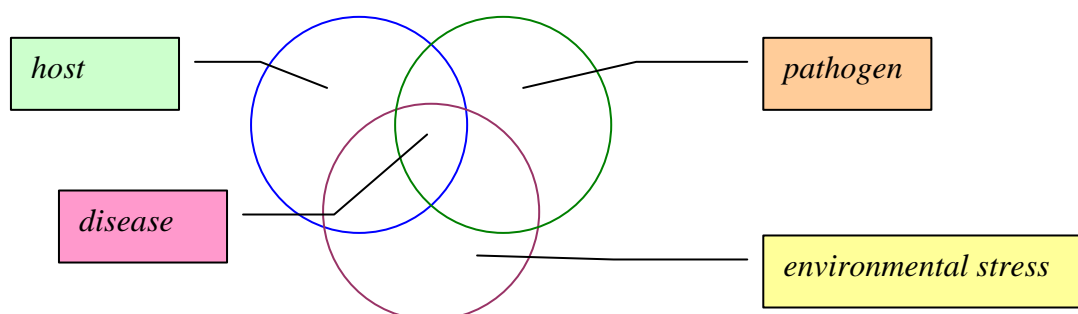

Host susceptibility means host becomes more susceptible to the pathogen. The weakness during the cultivation may lead to the degree of susceptibility to the pathogen. Moreover, the injury of fish during handling or transportation may open portal of entry of pathogen into the body. The virulence of fish pathogen also increases the degree of outbreak and the mortality of the host. However, the unbalance those factors will not lead to the disease outbreak. Whether host or pathogen is available in the good environmental condition, disease outbreak will not occur. However, the environmental stress is the most important factor leading to the outbreak such as low dissolve oxygen, high fluctuation of water temperature-pH and high toxic elements in the culture system. These stress conditions will lead to weakness of the host and may easily lead to disease infection.

Weakness and injury of the host may be occurred from the improper handling, transportation, nursing, culturing and nutritional deficiency which lead to increase disease susceptibility.



Therefore, the encouragement for good health will decrease the host susceptibility to the disease. Prevention of disease outbreak, the aquaculturist should pay more attention on proper farm management.

Sources of pathogen may come from many sources. The infected fishes from hatchery are the main source diseases. Therefore, fish seed should be come from the certified farm which has routine monitoring program from the certified organization or the farm owner itself. The others are the disease carriers from the natural resources such as fishes, snail, bird, leech, insects, birds and other animals.

### ***Sources of infection***

- Infected fish is the primary source of infectious disease.
- Natural fishes and aquatic animals are carrier sources of the disease.
- Infectious water supply.
- Improper feed can lead the parasitic diseases
  - e.g. *Mycobacterium sp.* in water flea.
  - e.g. Nematode can transmit through the feed for carnivorous fish.
- Man and his activity is a good source of infection.

### ***Mode of transmission of the pathogens***

- Water supply can transport the microorganism.
- Food is also the mode of transmission.
- Some parasites need intermediate host for transmitting.
- Some pathogenic organism is transmitted by some types of vector.
- Prevention of portal of entry

### ***Portal of entry***

- Wound and cut of the host are the way of pathogen to enter the fish.
- Bacteria have particular area for portal of entry.
  - Bacteria can infect membrane of gill, skin and any area.
  - When mucous is broken this will allow the infection.

### ***Virulence of microorganism***

- The ability of the pathogen to cause disease from high to low.
- After infection, the bacteria can increase virulence in a short period.

### ***Types of Disease***

- Parasitic diseases
- Bacterial diseases
- Viral diseases
- Mycotic diseases

## **1. Parasitic Diseases**

### ***Parasitic Protozoa***

Protozoa are animal comprised of a single cell capable of metabolism, reproduction and individual existence. They are the most primitive animals on the earth and have adapted to every possible ecological existence. Protozoa usually present in low numbers on or in fish residing in a natural environment may cause excessive parasitism if great care is not taken to provide suitable habitat and nutrition when the fishes are placed in under culture. The epizootics of parasitic protozoa can be observed as the indication that conditions are unsuitable to the fishes in some way but more suitable to the parasite. Taxonomic classifications on investigation of these parasites are described as followings.



- Class Ciliata.
  - *Ciliated protozoa: Trichodina, Trichodinella, Apiosoma, Carchesium, Epistylis, Zoothamnium, Ichthyophthirius, Chilodonella etc.*
- Class Suctorina.
  - *Trichophrya*
- Class Zoomastitophorea .
  - *Flagellate protozoa: Oodinium, Costia, Hexamita, Trypanosoma sp.*
- Class Rhizopodea
  - *Amoeba*
- Class Microspora
  - *spores of unicellular with/without polar filament*
  - *Pleistophora*
- Class Myxospora
  - *spores of multicellular with 2-3 valves, >2 polar filament*
  - *Henneguya, Myxosporus, Myxobilatus, Myxosoma cerebralis (Whirling disease)*
- Class Sporozoa
  - *Haplozoon*

***Platyhelminthes (Trematode- fluke worm)***

- Monogenea trematode
  - Mostly found on the skin but other habitat found on gill chamber, mouth-body cavity
  - *e.g. Thaparocleidus n. sp. Gyrodactylus Dactylogyrus etc.*
- Digenea trematode
  - Complex life cycle; larval generation, alternating sexual and asexual generation
  - *Diplostomum spathaceum; utilized many fish species as secondary intermediate host, fish-eating aquatic birds (sea gull) are primary host.*

***Acanthocephalans (hook worm)***

- *Leptorhynchoides sp.*

***Cestode (Tape worm)***

- Adult stage usually lives in the intestinal tract of vertebrates.
- Intermediate stage lives in the both vertebrate and invertebrate hosts.
- Ribbon shape with divided into segments called “proglottid”.
- *e.g. Bothriocephalus custpidatus* in walleye, *Proteocephalus pinguis* in northern pike, and *Ligula intestinalis* in fathead minnow, yellow perch

***Nematode (round worm)***

- *e.g. Contracaecum*

***Hirudinea***

- *Leeches*

***Crustaceans***

- Anchor worm (*Lerneae sp.*)
  - Female becomes adult on the fish host following fertilization by the male.
  - Female metamorphosis complete when the body form of a typical copepod changes to a bizarre creature no longer resembling a copepod.
- *Argulus sp., Ergasilus*



## 2. Bacterial Diseases

- Gram negative bacteria
  - *Aeromonas hydrophila*, *A.salmonicida*, *Flexibacter columnaris*, *Vibrio anguillarum*, *Pasteurella piscicida*, *Yersinia ruckeri*
- Gram positive bacteria
  - *Psuedomonas fluorescent*, *Streptococcus sobrinus*.
  - *Mycobacterium marinum*, *M.fortuitum* causes tuberculosis in marine & fresh water fishes.

## 3. Mycotic Diseases

- Saprolegniasis
  - *Saprolegnia parasitica* – water mold
  - Occur on wound, fish egg
  - *Achlya* and *Aphanomyces*
- *Aphanomyces* previously reported as an external wound pathogen on an aquatic animal was on a fish and also soft shell turtle.
- Found in EUS (epizootic ulcerative syndrome)

## 4. Viral Diseases

- Caused by DNA or RNA virus
- Lymphocystis
  - disease of connective tissue cells
  - infected cells become hypertrophic – tumour
  - Many freshwater – marine sp. are susceptible.
  - World wide distribution.
- Spring Viremia of Carp (rhabdovirus)
  - Infected in carp, guppy, pike, and grass carp.
  - Mortality decrease below 17 C and above 20 C
  - Cold water period are chronic but warm water period are acute.
- IPNV : Infectious pancreatic necrosis virus
  - Ovarian fluid and feces contain more virus particles.
  - Host: brook trout, rainbow trout, Atlantic salmon
- IHNV : Infectious hematopoietic necrosis virus
- VHSV : Viral hemorrhagic septicemia virus
  - Egtved virus ( Rhabdovirus)
  - Host : rainbow trout
- CCVD : Channel catfish virus disease
  - Herpes virus
  - Disease occurs at water temp. 22-28 C (94 % mortality)
  - High mortality in fry and fingerling.
- MrNV : *Macrobrachium noda* virus
- XSV : Extra small virus
  - virus disease in *Macrobrachium rosenbergii*
  - occur in > 10 day old larvae

## ENVIRONMENTAL STRESS

### 1. Water quality

- Improper water quality in physical and chemical may cause stress and weakness of the fishes.
- Sudden change or highly fluctuation of water temperature during a day
- High turbidity of water will decrease surface area of gill lamellae for oxygen consumption.

- Water velocity will affect on the strength of small and big fish in the cage culture.
- pH, alkalinity, dissolved oxygen, carbon dioxide, unionized ammonia, nitrite
- optimum pH 6.5 – 8.5
- Alkalinity =  $\text{OH}^-$   $\text{HCO}_3^-$  &  $\text{CO}_3^{2-}$  75-150 mg./l
- Some fishes prefer the low alkalinity / hardness water.
- The high fluctuation of pH in fish culture pond will relate to low alkalinity and phytoplankton bloom because phytoplankton uses carbon dioxide, carbonate and bicarbonate for photosynthesis.
- The optimum DO during fish culture should be between 5-10 ppm.
- If DO is lower than 3 ppm it will cause asphyxiation or hypoxia for prolong respiratory distress leads to death.
- Associated with muscular necrosis in shrimp; may result to mortality often before dawn.
- Heavy algal bloom may result in super saturation of dissolved gas (oxygen) leading to gas bubble disease. Gas bubble may form in gills, eyes, fin, skin and even in the visceral peritoneum; may result in formation of emboli (in blood) which block blood vessel resulting to gill necrosis and death.
- DO levels depend on number of phytoplankton, zooplankton, aquatic animals, temperature and atmosphere.
- Free  $\text{CO}_2$  should not higher than 6 ppm with the excess of DO in culture system.
- Unionized ammonia-UIA ( $\text{NH}_3$ ) should less than 0.02 mg./l depend on fish species.
  - UIA causing gill damage and UIA concentration depend on
    - o number of fishes
    - o type of foods and feeding rate
    - o pH; temperature
    - o phytoplankton
- High concentration of nitrite will cause brown blood disease; nitrite will combine with hemoglobin in the blood resulting methemoglobin or methemoglobinemia.

## 2. Nutritional deficiency

- Amino acids deficiency; arginine, valine
- Deficient of tryptophan causes lordosis / scoliosis (body conformation)
- Vitamin deficiency e.g. ascorbic acid, B 6-12, B-complex, Ca
- Rancid feed consume vitamin E (an important antioxidant) in the diet and are toxic. Fatty feed.

## 3. Receiving some chemicals

- e.g. insecticides, herbicides
- Causing weakness of the host.
- High pathogenic susceptibility.

### *Clinical sign*

- Behavior change
  - spiral movement (whirling disease)
  - no direction
  - Swimming without pattern
  - Scrubbing itself
- Feeding Rate
  - lower
  - No feed
- Coloration
  - Pale or darkening skin
  - 'yellow catfish disease' or 'catfish jaundice'
  - a hemolytic jaundice and anemia caused yellow skin



- Mucous
  - excess or less
- Hemorrhage
  - Petechiae (pin point)
  - Larger
  - External / Internal organ/ body cavity
- Wound
- Change of body shape
  - Swelling belly
  - Exophthalmia ; pop eye
- Necrosis
  - Dead cells or tissue
  - Gill rod, fin rod

## **DISEASE CONTROL**

### **Six methods use for disease control**

- Test and slaughter
  - Monitoring the fish routinely.
  - Proper destroy of the infected or dead fish.
- Quarantine and restriction of movement
  - Quarantine to observe the disease of the new arrived fishes for a certain time in the control area.
  - Restrict the movement of the infected fish
- Drug therapy and sanitation
  - Clean the hatchery and earthen pond routinely with proper disinfectant.
  - Use the suitable drug for a certain period.
  - Not all of drug could be used with food fish.
- Immunization and disease resistance.
  - Vaccination can be applied for any disease.
  - Developing disease- resistant stock
- Destruction or reduction of a link in the transmission cycle
- Limitation or control of release of toxic

## **TREATMENT**

There are several ways to treat the infected fish; however, the particular method should to treat with certain disease.

- Dipping treatment
  - Mostly use for external parasitic diseases; use in the hatchery/aquaria
  - All chemicals may harmful to epithelial layer of the skin and gill
  - Formalin 200-1000 ppm for 0.5-1.0 minutes
- Prolong treatment
  - Mostly use for external parasitic diseases ; use in the hatchery/aquaria
  - All chemicals may harmful to epithelial layer of the skin and gill
  - Formalin 75-150 ppm for 30-60 minutes.
  - Salt 0.5 – 1.0 %
  - Acriflavin 10 ppm for 1 hour: for bacterial treatment
  - Acriflavin 1:2500 for 30 min.: egg treatment
- Definite treatment
  - Can be use with parasitic or bacterial disease
  - Formalin 25-50 ppm may cause the DO depletion.
  - Salt 0.1 – 0.5 % or for transportation.

- Potassium permanganate 3-5 ppm may also cause the oxygen depletion.
- Acriflavin 2 ppm for bacterial treatment
- FDA proved chemicals.
- Oral treatment
  - Magnesium sulfate; Mebendazole
    - for internal parasitic diseases
    - Non effective to blood parasites sporozoan, Myxosporidian and Microsporidian
  - Antibiotic for medicated feed ;
    - Oxytetracyclin or Terramycin 3-5 g./ kg. of feed for 7-10 days with quitting period of 14-21 days before harvesting
    - Sulfamerazine 8-10 g./ kg. of feed for 10 days
    - Problem on the non appetite fish; high cost;
- Injection
  - Terramycin 20 mg./1 lb.of fish.
  - Suitable for small group of brood fish
  - Intramuscular / intraperitoneum injection

### Chemicals & Drugs

#### Acriflavin

- Prophylaxis: use for preventing bacterial infection during handling or transportation.
- 1 – 3 ppm
- expensive

#### Malachite green: zinc free oxalate

- Protozoa treatment 0.1 ppm
- Fungal treatment
- 1:15,000 (66.7 ppm) for 10-30 sec.
- 1:200,000 (5 ppm) for 15 min.
- Ichthyophthirius: 0.1 ppm + formalin 15-25 ppm
- Carcinogen; for non food fish

#### Lime

- Calcium hydroxide : hydrated lime, slake lime
- 60-80 kg/rai or 350-500 kg./ha
- Calcium oxide : quick lime
- More effective but more risk

#### Dipterex: organophosphate

- Dylox, Masoten, Néguvon
- Monogenetic trematode & Crustacean treatment
- Lernaea, Argulus , Ergasilus, Leech
- More toxic in high pH water
- 0.25 ppm ; for non food fish

#### Chlorine: Calcium/Sodium hypochlorite

- Disinfectant
- 10 ppm for pond treatment
- Highly toxic agent; irritate to the skin and respiratory tract.

#### Iodine: iodophore

- detergent disinfectant for farm premises
- poultry houses veterinary clinics
- food plants and commercial freezers
- Poultry drinking water sanitizer
- Hand sanitizing dip in meat and poultry processing plants

### Control Drugs in Food Fish



- Nitrofurazone group
- Chloramphenical
- Oxolinic acid
- Malachite Green
- Insecticides & Herbicides

## **DISEASE PREVENTION**

- Healthy fingerling from certified farm
  - High quality of brood stocks
  - Control of the parasitic diseases that come along with the fingerling.
  - Grow the same age / size of fingerling.
- Sanitation and disinfection
  - Dry and liming the nursery or grow-out pond. (350-500 kg/ha.)
  - Disinfectant; Calcium hypochlorite, Povidine iodine, Iodophore
- Clean water supply:
  - Reservoir
  - Filtration of water before using
  - Disinfection (hatchery)
- Proper handling; proper equipments and techniques in the farm.
- Proper transporting will decrease the stress and injury
  - Size and density of fingerling.
  - Proper temperature and duration during transportation.
  - Suitable vehicle and good traffic.
- Proper stocking density
- Proper feed; quality feed, feeding technique,
- Prevention of carriers, intermediate host and vectors
- Increase the disease resistance
  - Different host( size and strain) has different resistance to certain disease
  - Developing disease- resistant stock
- Monitoring program at proper period or pay more attention on fish behavioral change.

**FRESHWATER AQUACULTURE TECHNIQUES  
FOR RURAL DEVELOPMENT**

**Harvest and Post-harvest Techniques**

**SUBJECT PLAN**

<b>Subject</b>	Harvest and post-harvest techniques
<b>Date/Time</b>	6 July 2007, 09.00-10.00 hrs
<b>Officer-in-charge</b>	Mr. Bunchong Chumnongsittathum
<b>Objectives</b>	<p>After the subject, The participants will be able to:</p> <ul style="list-style-type: none"> <li>➤ Understand the concept of harvest and post-harvest techniques which including the fingerling transportation and the post harvest of the food fish..</li> <li>➤ Apply the related information and tools for harvesting and post-harvesting activity.</li> </ul>
<b>Topics</b>	<ol style="list-style-type: none"> <li>1. Introduction</li> <li>2. Packing Procedures</li> <li>3. Shipping Additives</li> <li>4. Receiving Fish</li> <li>5. Procedure for unpacking fish</li> </ol>
<b>Detailed Activity</b>	
<b>Time</b>	<b>Sub-activity</b>
<b>6 July 2007</b>	
<b>09.00-10.00</b>	<p><b>Harvest and post-harvest techniques</b>                      Explain on the ornamental fish packing, shipment and unpacking procedure. The food fish fingerling transportation in the country is also described.</p>



## HARVEST AND POST-HARVEST TECHNIQUES

*Pakorn Unprasert, Ph.D.*  
*Fisheries Technology Extension and Development Bureau,*  
*Department of Fisheries, Thailand*

*Lectured by Bunchong Chumnongsittathum*

### INTRODUCTION

One of the most critical determinants of the success of fish hatchery is the problem of delivering a quality product to market destinations. Fish fingerlings are confined within plastic bags that are inflated with pure oxygen, closed with rubber bands, placed in an insulated corrugated box, and sealed. The size and shape of these bags and boxes as well as the insulation can vary widely. During transport, the water in these closed containers may become oxygen-depleted, and may accumulate excessive carbon dioxide and consequently undergo a reduction in pH. Metabolic activity may also lead to elevated ammonia levels in the water, which can be damaging to fish health, or become lethal in extreme cases. A densely-packed shipping container increases these risks but reduces the cost of transportation at competitive prices. The purpose of this paper is to address some of the critical handling and packing methods that are essential for insuring the successful transport of live tropical fish to their final market destination.

### CARRYING CAPACITY

The maximum weight of fish that can be safely transported within a given period of time is the carrying capacity. The carrying capacity depends on the duration of haul, water temperature, fish size, and fish species. If water quality conditions such as temperature, oxygen, carbon dioxide, alkalinity, and ammonia are constant, then carrying capacity will depend on the fish species. In general, fewer kilograms of smaller fish can be transported per liter of water than larger fish. It is important that first time or experienced shippers handling a new species test-run a batch before undertaking a large shipment.

### WATER QUALITY DURING SHIPPING

Fish health is affected by changes in water quality parameters while in the plastic bags during the transportation process. The parameters to be considered are temperature, dissolved oxygen, pH, carbon dioxide, ammonia, and the salt balance of the fish's blood. The rate of change of each parameter is affected by the weight and size of fish to be transported and the duration of transport.

#### **Temperature**

Fish are cold-blooded, so the metabolic rate of fish is affected by the temperature of the environment. The metabolic rate of fish will double for each 18°F increase in temperature and be reduced by half for each 18°F decrease in temperature. A reduced metabolic rate will decrease the oxygen consumption, ammonia production, and carbon dioxide production. Temperature of 55° to 60°F is recommended. For species such as tilapia and red temperature: should be nearer to 60°F. Cold water fish, such as trout, inhabit colder water and should be transported at even colder temperatures, such as 45° to 50°F. To achieve the desired transport temperature, fish should be held in tanks of cool water. By holding the fish in tanks for two days, the water temperature can be gradually reduced by adding cool water. After loading the fish into bags, final decreases and maintenance of temperatures during transport can be accomplished by adding ice or (more commonly) gel packs. Ice or gel packs often are used during transport, especially over longer transport periods that might allow increases in temperature. One-half pound of ice will reduce the temperature of one gallon of water by about 10°F. Insulated Styrofoam shipping boxes also are



used to prevent outside temperatures from affecting the temperature of transport water. In some instances, 20 to 40 quart coolers are used for transport.

### **Dissolved Oxygen**

Oxygen requirements for live fish are related to: 1) body size; 2) ambient temperature; 3) nutritional state, and; 4) metabolic rate. Oxygen consumption increases with temperature, body size and activity level. Diurnal rhythms also affect oxygen demand. Handling and packing procedures should be designed to keep metabolic rates at a low level. The most important single factor in transporting fish is the adequate concentrations of dissolved oxygen (DO). The importance of supplying adequate levels of DO cannot be over emphasized. Failure to do is resulted in severe stress which may contribute to fish kill two to three days after transport. The amount of oxygen that can be dissolved in fresh water is based primarily on water temperature. The water is referred to as 100% saturated when the upper saturation level is reached. DO saturation is higher for cool water than for warm water. For example, at sea level DO saturation of 45°F water is 12.1 parts per million (ppm) but at 60°F saturation is 10.0 ppm. Because pure oxygen is used during bag transport, DO levels in the water will be saturated and the low oxygen levels usually will not be a problem unless the bag is improperly sealed or develops holes caused by the spines of large fish. It is important to have a 75 percent volume of oxygen in the bag to insure adequate diffusion of oxygen at the surface of the water.

### **pH**

The quantity of hydrogen ions (H<sup>+</sup>) in the water will determine if it is acidic or basic. The scale for measuring the degree of acidity is called the pH scale, which ranges from 1 to 14. A value of 7 is considered neutral, neither acidic nor basic; values below 7 are considered acidic; above 7 basic. The acceptable range for fish growth is between pH 6.5 and 9.0. The pH of water will be influence by the alkalinity (buffering capacity) and the amount of free carbon dioxide. The pH of the transport water will also affect the toxicity of ammonia

### **Carbon Dioxide**

As fish respire they produce carbon dioxide as a by-product. Carbon dioxide reacts with water to form a weak acid. This weak acid will in turn decrease the pH of the water. High levels of carbon dioxide (greater than 20 ppm) will interfere with the oxygen uptake in the fish's blood. High levels of carbon dioxide sometimes are found in well water. Excess carbon dioxide in well water can be reduced by mechanical aeration or by passing the water through a degassing column.

## **FISH TRANSPORTATION**

### **Bags**

Many of the domestic producers use square bottom bags. These bags utilize the surface area of the box more efficiently. Use of a pleated bag (flat bottom) is highly recommended. Pleated bags utilize the entire surface area of the box allowing maximum oxygen transfer through the surface of the water. They also reduce the effects of crowding by utilizing all of the available area in the box. If the bag is properly placed in the box, crowding in the corners by the fish is kept to a minimum. Boxes are generally packed in bag sizes of full to the corners by the fish are kept to a minimum. Boxes are generally packed in bag sizes of full to quarter. Full bags are those that utilize the entire box, half bags are packed two to a box, quarter bags four to a box. These bags have the following dimensions: full size, 37.5 cm (W) x 37.5 (L) x 55 cm (H), half size, 40 cm x 20 cm x 55 cm, and quarter bags at 40 cm x 10 cm x 55 cm. Square-bottom bags are available pleated and flat.

### **Boxes**

There are many different styles and types of boxes routinely used in the ornamental fish industry. The most commonly used is molded by styrofoam. Ornamental fish packed from Asia frequently make use of one of two size boxes, 60 cm (L) x 42 cm (W) x 30 cm (H) or, 49 cm (L) x 38 cm (W) x 38 cm (H). The larger of these two types are packed with a minimum of four bags. Although there are many different sizes and shapes used for shipping ornamental fish.

### Packing Procedures

A schematic diagram illustrating the typical processes involved in packing and shipping is presented in Figure 1. Before harvesting and packing it is important to have all required material available. Any chemicals needed for pond treatment of parasites should be on hand. Insure that there is adequate room in holding tanks to house the harvested fish as well as extra tanks for sorting by size and \ or sex. A comfortable sorting table in a clean, well-lit area. Suitable bags for packing should be in stock as well as the insulated styrofoam inserts and outer boxes, all other critical supplies to have include a full oxygen cylinder and regulator to inflate the bags, rubber bands to seal the bags, and tape to seal the boxes. If any of these items are missing, packing should not be attempted.

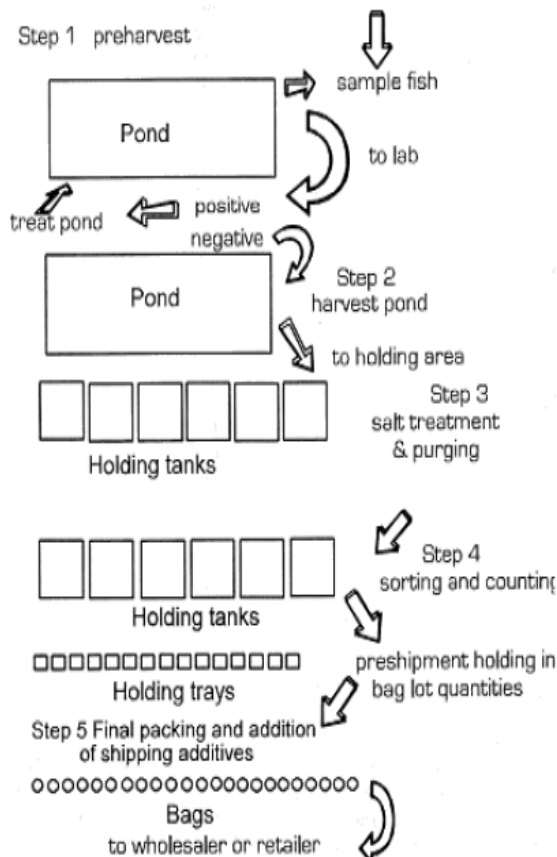

Figure 1. Flow-chart of fish packing steps and procedures.

**Step 1.** Pre-harvest Fish should be examined for parasites and diseases at least one week prior to harvesting. This allows sufficient lead time, should and treatments be necessary.

**Step 2.** Postharvest Fish brought into the holding tanks for sorting and sale should be checked again for parasites and diseases. Holding tanks should have adequate water and aeration. Iodine free salt (NaCl) can be added to the holding tank water at nine parts per thousand (9.0 ppt.). This provides an isotonic salt solution, which is effective in reducing stress and promoting a natural slime coating. This helps prevent opportunistic infection as a result of handling injuries.

**Step 3.** Feeding should be withheld for a minimum of two days and up to five days, depending on species. For example livebearers such as swordtails and monies require two days, whereas goldfish and carp require four days. The feces should be siphoned out of holding tanks once or twice a day to prevent the fish from eating feces. The absence of feces in the tank will indicate that fish have had an adequate purge time prior to sorting, counting and shipping.

**Step 4.** Fish are now sorted and counted into bag lot quantities and held in individual aquaria, trays or buckets. The pre-shipment containers should have adequate water and air flow. The water exchange rate in these containers should be a minimum of four times per day (4x/day). Ideally, the pre-shipment holding containers should have a standpipe or valves to allow the water to drain to the correct shipping volumes. The fish and water can then be poured directly into the shipping bag, which saves time and minimizes handling.

**Step 5.** Any shipping additives are placed into the bag at this time. The bag is purged of air and pure oxygen is injected into the bag below the water surface. The bag is then sealed using rubber bands or one of the commercial grade sealers and placed in its box. Ice packs can be laced on after seal for best results. Avoid fish over chill. Do not allow the gel pack to touch the bag directly. Newspapers or other similar material can be used as a buffer between the coolant and the bag.

**Shipping Additives**

Over the last 15 years, several additives to shipping water have been developed or adapted to help reduce stress and increase survivability. They generally fall into three categories: sedatives water quality stabilizers, and antibiotics. The most common sedatives are quinaldine or quinaldine sulfate, and Tricane methane sulfonate (MS-222), Quinaldine is used 25 ppm in shipping water, MS-222 at 60 to 70 ppm with adjustments made for sensitive species. These compounds reduce the metabolic rate of fish, and can also prevent injury from jumping or swimming into the sides of the box. Water quality stabilizers include pH buffers, zeolite at 20 g./ liter (which removes ammonia), activated carbon also at 20 g./liter, ice or heat packs to maintain temperature, and sodium chloride at 9.0 ppt. Other products have become available from the bait minnow industry these usually contain a combination chelating agents, buffers, ammonia or chlorine removers and some form of antibiotic.

**Table 1.** Common shipping additives and concentrations typically used in water for transport of ornamental fish, Adapted from Herwig, 1979.

Concentration	Chemical
Quinaldine	25 ppm
Tricane methane sulfonate (MS-222)	60 - 70 ppm
pH buffers	as per label
Zeolite	20 g./L
Activated carbon	20 g./L
Salt (NaCl)	9.0 ppt
Commercial mixtures	as per label
Furanace	0.05-0.2 ppm
Neutral acriflavine	3-10 ppm

Caution should be used in the application of antibiotics. These compounds are subject to regulatory controls, which should be considered carefully before any applications. One of the most widely used antibiotics for shipping and treatment of fish has been tetracycline at 5-20 ppm. This antibiotic has been used extensively, especially from fish shipped out of Asia. There are several indications that some bacteria have developed immunity to tetracycline due to its wide use, which is one of the reasons that not recommend its use. Other antibiotics commonly used in shipping are furanace at 0.05-0.2 ppm, and neutral acriflavine at 3-10 ppm. Other antibiotics such as kanamycin and chloramphenicol are used much less frequently and are primarily used as on-farm treatments for disease. The different sulfa base drugs are currently being used due to bacterial resistance to other forms of antibiotics historically used in the industry.

**Receiving Fish**

Most farms that ship fish will also be receiving fish, either to resell or to add to their brood-stock line. Appropriate care and handling of incoming shipments of fish is another critical function to a successful farm or transship operation. Arriving shipments should be inspected immediately,

particularly those that have been shipped over long distances or those which have been subject to delays. Fish that are densely packed in bags that have taken longer than expected to arrive may be suffering from exposure to accumulations of ammonia, thermal shock, or other problems. A quick assessment of the condition of the arriving fish can limit losses in such cases. In order to implement, a successful receiving program you must first have a working knowledge of what changes are taking place, chemically and physically, inside the shipping bag during the transport period. Once a bag has water, fish and oxygen sealed inside it, certain chemical changes take place due to the metabolism of the fish. When fish breathe, they absorb oxygen and excrete other gases and metabolites, primarily carbon dioxide (CO<sub>2</sub>) and nitrogen in the form of ammonia. Total ammonia nitrogen for the purposes of this manual, consists of two forms of nitrogen that exist in a pH and temperature dependent equilibrium of unionized ammonia (NH<sub>3</sub>) and the ammonium ion (NH<sub>4</sub><sup>+</sup>). The un-ionized form (NH<sub>3</sub>) is toxic to fish while the ammonium ion (NH<sub>4</sub><sup>+</sup>) is not toxic to fish (Boyd, 1979). The ratio of NH<sub>4</sub><sup>+</sup> to NH<sub>3</sub> will increase as pH decreases and decrease as pH increase (Boyd 1979). The percentage of NH<sub>3</sub> also rises with increasing temperatures so conditions with both relatively high pH and elevated temperature are especially dangerous. Since NH<sub>3</sub> cannot be measured directly, several tables have been created based on an equilibrium formula that predicts the relative percentages of unionized ammonia at different temperatures and pH. Table 2 was created for the aquaculture industry and reproduced from Boyd (1979).

**Table 2.** Percentage un-ionized ammonia in solution at different pH values and temperatures. (Reproduced from Boyd 1979).

pH	Temperature (°C)								
	16	18	20	22	24	26	28	30	32
7.0	0.30	0.34	0.40	0.46	0.52	0.60	0.70	0.81	0.95
7.2	0.47	0.54	0.63	0.72	0.82	0.95	1.10	1.27	1.50
7.4	0.74	0.86	0.99	1.14	1.30	1.50	1.73	2.00	2.36
7.6	1.17	1.35	1.56	1.79	2.05	2.35	2.72	3.13	3.69
7.8	1.84	2.12	2.45	2.80	3.21	3.68	4.24	4.88	5.72
8.0	2.88	3.32	3.83	4.37	4.99	5.71	6.55	7.52	8.77
8.2	4.49	5.16	5.94	6.76	7.68	8.75	10.00	11.41	13.22
8.4	6.93	7.94	9.09	10.30	11.65	13.20	14.98	16.96	19.46
8.6	10.56	12.03	13.68	15.40	17.28	19.42	21.83	24.45	27.68
8.8	15.76	17.82	20.08	22.38	24.88	27.64	30.68	33.90	37.76
9.0	22.87	25.57	28.47	31.37	34.42	37.71	41.23	44.84	49.02
9.2	31.97	35.25	38.69	42.01	45.41	48.96	52.65	56.30	60.38
9.4	42.68	46.32	50.00	53.45	56.83	60.33	63.79	67.12	70.72
9.6	54.14	57.77	61.31	64.54	67.63	70.67	73.63	76.39	79.29
9.8	65.17	68.43	71.53	74.25	76.81	79.25	81.57	83.68	85.85
10.0	74.78	77.46	79.92	82.05	84.00	85.82	87.52	89.05	90.58
10.2	82.45	84.48	86.32	87.87	89.27	90.56	91.75	92.80	93.84

Generally when a bag of fish reaches its final destination it has been in transit for 24 to 48 hours. During this period of time there has been enough carbon dioxide produced to reduce the pH of the water down to 6.5 - 7.0. As you can see from Table 2, using a temperature of 24°C and a pH of 7.0, the toxic fraction is only 0.52 percent. If the total ammonia nitrogen is 10.0 parts per million (ppm) then the toxic fraction is only 0.052 ppm. (0.0052 x 10.0 = 0.052 ppm). This amount of toxic ammonia (NH<sub>3</sub>) is well within the tolerable limits for long term exposure to most species without doing any serious physiological damage to the fish (Post, 1987). However, if the pH in that same bag of fish is 10.0 and the temperature is 24 C the un-ionized toxic fraction of ammonia from the chart above is 84.0 percent or 8.4 ppm (0.84 x 10.0 = 8.4 ppm). At this level severe stress, physiological damage and even death may occur at exposure times as short as 30 minutes or less (Post, 1987).

### Procedure for unpacking fish

Unpacking is as important as packing fish in bags. Guidelines for proper unpacking are as follows.

1. Float unopened bags in a shaded area of the receiving water for at least 30 minutes to allow temperate to equalize.
2. Check water temperature and watch for mortalities.
3. Open bags and add a few of receiving water to the bag.
4. Carefully observe the fish acclimated itself to the new environment
5. Gently and slowly pour fish into the receiving water.

It is critically important when receiving fish to be aware of the temperature and pH differences between the water in the shipping bag and the receiving water. The bag should be kept out of direct sunlight. The recommended method for acclimating fish is to float the sealed bag in the tank or pond that is to receive them for a period of at least five minutes per degree of temperature difference or until the temperature of the bag is within two degrees of the receiving water. The CO<sub>2</sub> in the shipping water will dissipate into the atmosphere and the pH of the shipping water in the bag will begin to increase rapidly along with the toxic fraction of ammonia, potentially causing severe stress or death. Adding water to an unsealed bag may only increase stress if the water being added has a high pH and temperature. At this point in the receiving procedure un-iodized salt may be added to reduce stress. Fish should also be inspected under the microscope for any parasites or disease and the proper treatment applied. Generally, water in shipping bags is discarded rather than introduced into the culture system as a means of limiting possible introductions of pathogens, anesthetics, etc.

## **SUMMARY AND CONCLUSIONS**

Even the most effectively run hatchery fish production operation is likely to fail if insufficient attention is paid to fish packing and shipping procedures. This can be summarized as a matter of minimizing risks at every step of the packing and transport process, without going to the costly excess of shipping bags. Packing methods should take into account the species being shipped and the expected time in transit. Concentrating sales in easily reached destinations, and adherence to established packing methods, materials, and densities described in this manual will contribute to the consistent delivery of fish in excellent condition. An effectively designed packing room, with harvests prepared appropriately in anticipation of shipping deadlines.



## CHAPTER 4

### AQUACULTURE-BASED RURAL LIVELIHOOD PROGRAM PLANNING

#### SUBJECT PLAN

<b>Subject</b>	Aquaculture-based Rural Livelihood Program and Planning
<b>Date/Time</b>	8-13 July 2007
<b>Officer-in-charge</b>	Mr. Renato Agbayani
<b>Objectives</b>	After the subject, the participants will be able to: <ol style="list-style-type: none"> <li>1. Understand and apply community-based and participatory approaches in promoting sustainable rural aquaculture projects</li> <li>2. Understand and apply technology transfer approaches and strategies in promoting sustainable rural aquaculture</li> <li>3. Understand and apply business planning methods in sustainable rural aquaculture</li> </ol>
<b>Topics</b>	<ol style="list-style-type: none"> <li>1. Community-based Aquaculture and Resources Management: Concepts and Approaches</li> <li>2. Participatory Approaches in Rural Appraisal and Development</li> <li>3. Technology Transfer of Aquaculture Technologies: Framework and Strategies</li> <li>4. Business Planning and Management for Sustainable Rural Aquaculture Venture</li> </ol>
<b>Detailed Activity</b>	
<b>Time</b>	<b>Sub-activity</b>
<b>8 July 2007</b>	
0900-1200	<ol style="list-style-type: none"> <li>1. Community-based Aquaculture: Concepts and Approaches                      Discuss the concepts and approaches of community-based aquaculture and resource management, principles of sustainable aquaculture, property rights, and territorial rights in fisheries. This will be mostly lecture but will encourage interaction from the trainees in terms of the own knowledge and experiences related to the topic.</li> </ol>
1330- 1600	<ol style="list-style-type: none"> <li>2. Participatory rural appraisal for rural development                      PRA tools and techniques will be discussed. These tools will be used by the trainees in their fieldwork</li> </ol>
<b>9 July 2007</b>	
0900-12:00	<ol style="list-style-type: none"> <li>3. Transfer of Aquaculture Technologies: Strategies and Pathways                      Using SEAFDEC AQD Framework, discuss the different stakeholders of aquaculture technology and information, strategies and pathways</li> </ol>
1330-1400	<ol style="list-style-type: none"> <li>4. Business Planning and Management for Sustainable Small-scale Rural Aquaculture Venture                      Discuss the business aspects of an aquaculture enterprise including organization and management, marketing systems, simple financial analysis, as well as environmental and policy concerns. Simple record keeping forms will also be discussed.</li> </ol>
<b>11-12 July 2007: Field Practical Sessions and Site Visits</b>	
11 July	<ol style="list-style-type: none"> <li>1. Visit low-income fish community and use participatory tools and techniques for rural appraisal and aquaculture project development.</li> <li>2. Visit fish spawning site and evaluate project based on business planning tools</li> </ol>
12 July	<ol style="list-style-type: none"> <li>1. Visit high-income fish community and use participatory tools and techniques on rural appraisal and aquaculture project development.</li> <li>2. Visit integrated farming site and evaluate project based on business planning tools.</li> </ol>
<b>13 July 2007</b>	
1030-1200	<ol style="list-style-type: none"> <li>1. Preparation of Field Practical Session Presentation</li> </ol>
1300-1500	<ol style="list-style-type: none"> <li>2. Presentation and Discussion on the Results of Field Practical Session</li> </ol>



## COMMUNITY-BASED AQUACULTURE AND RESOURCE MANAGEMENT: CONCEPTS AND APPROACHES

*Renato F. Agbayani*  
*Head, Training and Information Division,*  
*SEAFDEC/AQD, Tigbauan, Iloilo, Philippines*

### INTRODUCTION

Poverty characterizes most fishing communities in the Southeast Asian region. In the Philippines, the socioeconomics survey of the National Statistics Office shows that 684,500 or 95.3% of the total 718,267 fishing families belong to the low-income group (Herrin and Racelis, 1992). The poverty of fisherfolk is directly caused by the widespread degradation of marine and coastal resources (Lacanilao, 1989), their low educational attainment, lack of skills for alternative livelihood and non-empowerment in local governance (Agbayani, 1995).

Producing food, generating employment and providing basic social services for the burgeoning population, and earning foreign exchange to fuel economic development, are among the top priorities of the Asian region. The region's vast and rich coastal and inland water waters have been a major source of adequate and cheap protein food and livelihood for the people. In the past, the seas teemed with fish. But over the years, overfishing, destructive fishing practices, indiscriminate cutting of mangroves, and industrial and human wastes have gradually depleted the rich aquatic resources.

Aquaculture has become the fastest growing food activity in the world, according to FAO 1996 State of World Fisheries and Aquaculture. In Asia, aquaculture has expanded sevenfold during the past eleven years and has contributed substantially to the region's food security, employment generation, and foreign exchange earnings. About 43% of all fish eaten today globally comes from aquaculture (FAO 2006)

The phenomenal growth of aquaculture in the Asia-Pacific region during the last two decades was market-driven. Appropriate technologies were developed. Governments in the region came up with policies supportive of the industry such as tax incentives, infrastructure development, and exemption of fish farms from land reform programs. Production and export of high value species went in high gear during the 1980s; however, problems related to environmental degradation, particularly water pollution, increasing cost of imported feeds, and destruction of mangroves decelerated production and drastically eroded profits.

Social problems erupted. Small-scale fishers dependent on coastal resources have been adversely affected by the conversion of mangroves to ponds and by the destruction of coral reefs caused by siltation and destructive fishing practices. In the 1970s and 80s researchers, policy makers, and resource managers treated aquaculture merely as farm activity; in the 1990s, they started to look into the bigger picture of sustainability.

The general objective of this course, therefore, is to reconcile aquaculture technology and sustainability development. At the end of the course, the participants are expected to obtain: (1) know the basic concepts and principles of sustainable aquaculture and coastal resources management, and importance of biodiversity conservation; (2) learn practical techniques in resource and ecological assessment; (3) understand the important socioeconomic, institutional, and environmental issues affecting sustainable aquaculture development and resource management ; and, (4) relate sustainable aquaculture technology to resource management; and, (5) apply the provisions of the Code of Conduct on Responsible Fisheries and other relevant legislation concerning sustainable aquaculture and coastal resource management.



## **CONCEPTUAL FRAMEWORK**

The basic elements that will have to be considered in the project formulation on sustainable aquaculture and coastal resources management are: 1) people or the socioeconomic attributes of the community; 2) biophysical characteristics of the coastal and land-based resources; 3) traditional and other existing institutional rules and regulations in the management of resources; and, 4) status of fishing and aquaculture technology in the community (Fig. 1). Market attributes will have to be looked into by project implementers to support the marketing efforts of fish and non-fish products and services from the community.

The integration of the basic elements of the project through an interdisciplinary approach is important in order to understand fully the social dynamics in adoptinmg technologies to get economic benefits from the coastal resources.

The integration process will lead to two action situations; technology transfer and adoption on one side and property rights regimes and institutional arrangements on the other side. The technology transfer and adoption mechanisms will require both research undertaking and development interventions.

Property rights and institutional arrangement s define the rules and rights in the management of common properties such as mangrove forests and other coastal resources. The property rights in mangrove areas is a grant of authority from the state to the users in form of tenurial rights and stewardship agreements.

The effects of the two action situations (technology and resource management) will lead to several patterns of interactions or behaviours among the resource and technology users. These behaviours are: 1) “free rider”; 2) reciprocity; and 3) collective action. The most ideal pattern of interaction is the collective action of the community of resource users. In this behaviour, the resource users are interested in attaining a common goal and benefit for all. The two behaviours are individualistic and opportunistic.

The long-term outcomes of the project will be measured in terms of efficiency, sustainability, and equity.

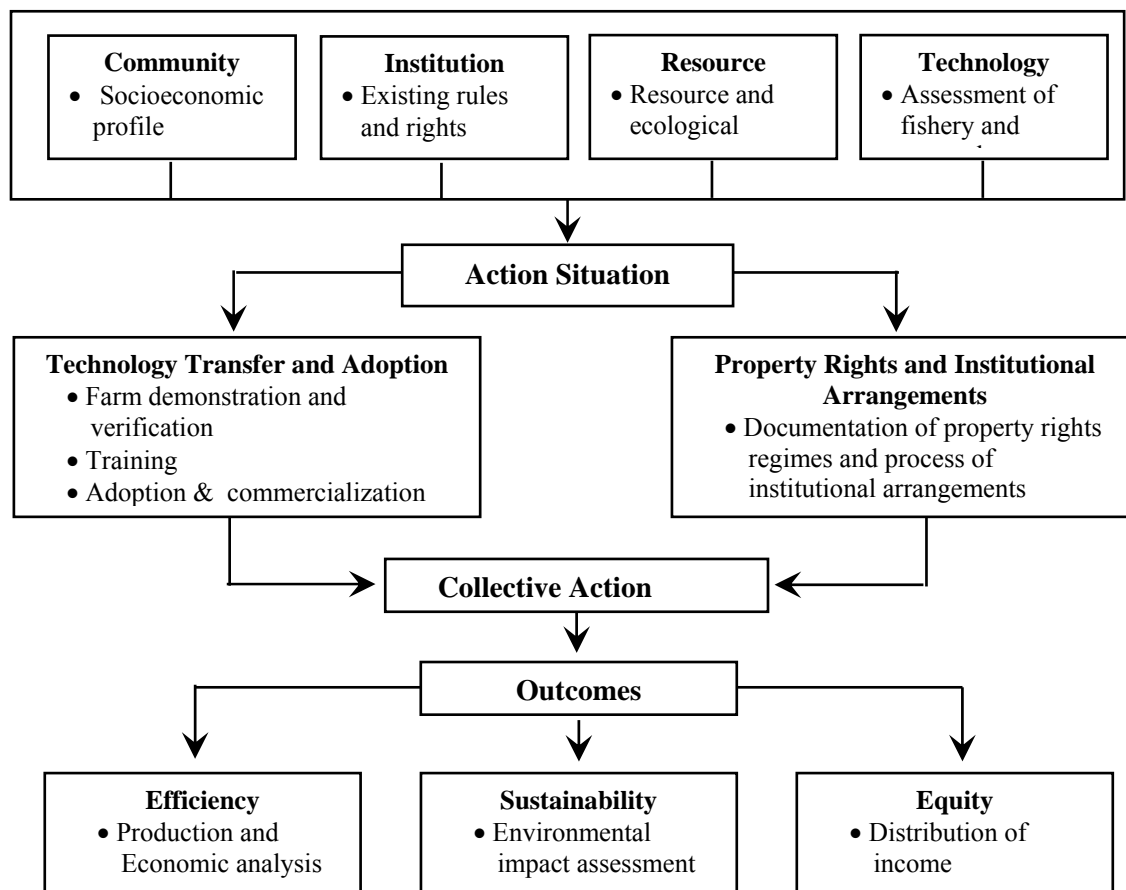

Figure 1. Framework for Community-based Aquaculture and Resource Management

Using the conceptual framework, a research and development agenda can be prepared consistent to the interrelationship between and among the basic elements of the projects and the long-term outcomes.

1. Socioeconomic studies will provide base line information on the sociodemographic attributes of the community. Socioeconomic impact analysis will be done to evaluate the technical and economic efficiencies of the mangrove-friendly technologies. Resource valuation studies on mangrove and other coastal resources (corals and seagrasses).
2. Biophysical and environmental studies will assess the mangrove and other coastal resources before, during and after the management and development interventions.
3. Technology transfer and adoption will include actual field demonstration and verification of mangrove-friendly aquaculture systems. Training and extension services will ensure correct adoption of the technologies and eventual commercialization.
4. Policy studies will document and analyze the process, formulation, and implementation policies and institutional arrangements specially issues pertaining to property rights.

## PRINCIPLES OF SUSTAINABLE AQUACULTURE

FAO defines *sustainable development as the management and conservation of the natural resource base and the orientation of technological and institutional change in such a manner as to ensure the attainment and continued satisfaction of human needs for present and future generations. Such sustainable development (in the agriculture, forestry and fisheries sectors)*

*conserves land, water, plant and animal genetic resources, is environmentally non-degrading, technically appropriate, economically viable and socially acceptable.*

Sustainable aquaculture includes the following principles: (1) maintenance of ecological systems; (2) improvement in economic and social well-being; (3) inter-generational equity; (4) intra-generational equity; and, (5) adoption of precautionary approach (Insull and Shehadeh, 1996). Maintenance of ecological systems applies to the impact of aquaculture production systems on the resources. It is necessary that the entire ecosystems (from the forest down to the coastal areas) be considered in aquaculture development. Improvement of well-being (both human and resources) include better and diversified incomes, improved access to essential services (health, education, credit etc.), maintenance of good social relations and conservation of natural resources. Intergenerational equity is the principle of using the resources for the present economic needs but at the same time conserving them for future generations. Intergenerational equity refers to equitable access and use of the natural resources by the different sectors of society. Precautionary approach refers to being cautious especially if there is a risk or potential irreversible damage to human beings and to nature.

Mangrove forests, seagrass beds and coral reefs, form part of the coastal ecosystems that support coastal resources. Consisting of intertidal flora and fauna, mangrove forests thrive in the tropic and subtropical regions of the world. More than a quarter of this important resource is found in Southeast Asia (Spalding *et al.*, 1997) and have contributed significantly to the socioeconomic well-being of the coastal communities (Field, 1995).

The destruction of mangroves and other coastal environments caused by shrimp farming has also led to the deterioration of local livelihoods (Barraclough & Finger-Stich, 1996) due to conversion and privatization of mangroves and other lands, salination of soil and water, impoverishment of local populations, and food insecurity. While aquaculture is considered as a key alternative to meet problems on food security, its development, however, in the Southeast Asian region has always been market driven. The export demand for shrimp and other high-value species encouraged governments and investors in the region to convert mangrove forests to shrimp ponds. In the Philippines, for example, large scale aquaculture was facilitated by the government with the issuance of P.D. 704 in 1975 with a fisheries decree accelerating fishpond development and BFAR A.O. 125 in 1979 converting fishpond permits from 10-year lease agreements to 25 years.

Added to this ecological disturbance was the adoption of intensive systems to maximize profit, on the part of investors, and provide Southeast Asian economies with the much needed foreign exchange. The adoption of unsustainable aquaculture technologies and the devastation of mangrove forest became a social problem. The economic benefits realized in terms of private profits for big-time shrimp investors, taxes paid to the government by shrimp growers, foreign exchange inflow earnings, and employment of skilled technicians were all negated by the adverse impacts on mangroves and other coastal resources to the detriment of impoverished fishing communities. Moreover, the uncontrolled destruction and exploitation of mangrove resources can be attributed to the lack of property rights regimes and institutional arrangements in managing coastal resources. Mangrove forests are technically government-owned common property where access and use is open to all.

The advent of aquasilviculture provides options for ensuring food security through the practice of mangrove-friendly aquaculture techniques. Aquasilviculture involves more traditional, non-destructive aquaculture techniques combined with sustainable forestry techniques, including limited harvest of mangroves (Primavera, 1993). However, local situations should first be considered before technology interventions are introduced to ensure sustainability of both the resource and the technology.



## APPROACHES AND STRATEGIES

### Property Rights

The “open access” character of the coastal waters have led to overfishing. The expression “*the tragedy of the commons*” (Hardin, 1968) has come to symbolize the degradation of the environment to be expected whenever many individuals use a scarce resource in common.

Common property resources are those to which access is both free and open to a set of users or potential users (Christy, 1982). There are several consequences that result from the condition of common property:

1. There is a tendency to waste the resource physically;
2. There is economic waste;
3. Average income of small-scale fishers tend to be close to the bottom scale; and
4. Conflict on resource use arise

The above-stated consequences are very much evident in the Southeast Asian countries. There has been physical (biological) waste in the catch of fish byproducts in fishing expeditions which are either thrown away or used minimally. Milkfish fry gatherers have been observed to be throwing away other species instead of putting them back into the waters.

Too much fishing effort in terms of capital and labor is wasted in catching too little fish leading to economic loss. Commercial fishers have been known to be encroaching on municipal waters in competition with small-scale fishers which has further led to overfishing and consequently low catch for both type of fishers but more so for the small-scale fishers. The “economic rent” (difference between the total revenues and total cost) is dissipated leading to economic loss.

Conflicts between and among different fishers and other stakeholders arise because of different needs, perceptions, and objectives in the utilization of a common resource.

Gordon (1954) stated that “*there seems to be some truth to the dictum that everybody’s property is nobody’s property. Wealth that is free for all is valued by no one because he who is foolhardy enough to wait for its proper time of use will only find that it has been taken by another... the fish in the sea are valueless to the fisherman, because there is no assurance that they will be there for him tomorrow if they are left behind today*”. In economic terms, fishers have high discount rate so that the flow of benefits today is better than the flow of benefits in the future.

An influential model in common property is the logic of collective action (Olson, 1965). The model suggests that groups that tend to act in support of their group interests are supposed to follow logically from a widely accepted premise of rational, self-interested behavior. If the members of some group have a common interest and if they would all be better off if that objective were achieved, it has been thought to follow logically that the individuals in that group would, if they were rational and self-interested, act to achieve a common goal. Olson, however, argued that unless the number of individuals is quite small, or unless there is coercion or some other special device to make individuals act in their common interest, a rational and self-interested individuals will not act to achieve their common or group interest.

Property rights can be classified as public (state), common (community or group of users), and private (individuals or companies). Property rights holders are provided incentives for natural resource management and authorization and control over the resource. Assigning property rights to the resource users such as the community reinforces collective action and shows the commitment of government to devolution of natural resource management. It gives a “sense of ownership” to the holders in order that they will take care of the resource. It is important that the community is recognized as the legitimate property rights holder with the backing of the government in order to effectively enforce the rules and rights in the management and utilization of the coastal resources.

The concept property rights include a bundle of rights which are derived from the government, customary, religious law, and other normative frameworks (Meinzen-Dick and Knox, 1999). The bundle of rights is comprised of: **use** rights, including access (to enter the resource domain) and withdrawal (to remove something); **control** rights, including management (to modify or transform the resource) exclusion (to determine who else may use the resource), and alienation (to transfer rights to others) (Schlager and Ostrom, 1992 in Meinzen-Dick and Knox, 1999).

The concept of property rights as a resource management strategy requires the collective effort of different users and stakeholders. The property rights in mangroves is a grant of authority from the state to users in the form of tenurial rights and stewardship agreements. These rights are guided by rules on what acts are permitted and forbidden in exercising the authority provided by the right. Well-specified property rights provide incentives for either individuals or groups to invest in resources and maintain them over time in order to obtain benefits. Property rights are characterized by: 1) exclusivity or the right to determine who can use or access the resource; 2) transferability or the right to sell, lease or bequeath the rights; and, 3) enforcement or the right to apprehend and penalize violators of the rights (Randall, 1987).

In the devolution of coastal resource management as provided for by the Local Government and the Fisheries Code in the Philippines, the critical sets of rights are the control rights of management and exclusion. Local Government Units can zone the municipal waters to identify the areas for different uses. It can exclude unauthorized users to protect the legitimate property right holders. Property rights regimes can only be as strong as the institutions that support them. Local Government Units (LGUs) must have political will to enforce the laws that will exclude encroachers (commercial fishers, for example) in municipal waters.

There are cases where claims on the resources are based on customary rights where claimant has a long period of usage of the resource and or had substantial investment in developing the resource. An example is the customary use rights of mangrove areas where generations of families have been using the resource like extracting wood and other commodities. Customary rights exist in cases where that era no laws governing the use of resource or where law enforcement is weak. Religious laws may not allow extracting water from specific sources. In some communities, local norms may not allow women to use some natural resources.

### **Public vs Private Control of Common Property Resources**

There are authors who advocate that common property resources require public control if economic efficiency is to result from the development. Centralized government control on natural resources have been adopted in developing countries especially among “iron governments” or perhaps military governments. Smaller countries like Singapore and Brunei have been relatively successful in centrally controlling and regulating the use of natural resources. Big countries that are highly centralized or authoritarian cannot claim the same results (Russia and other East European countries) where environmental destruction was rampant in exchange for economic development.

The proponents of centralized government control want an external government agency to decide the strategy (who, how, where, when) on using the resource. In the Philippines, the national government adopted a “top-down strategy” in formulating policies in the utilization of common-pool resources such as fisheries prior to the enactment of the Local Government Code (LGC) of 1991. Resource users and stakeholders were seldom consulted in the planning and policy formulation process. The destruction of coastal resources and the marginalization of fisherfolk are the results of this strategy.

Other policy analysts advocate the imposition of private property rights in order to avoid inefficiency in the use of common pool resources. This strategy, however, may work in land



resources but is doubtful in non-stationary resources such as fishery resources where establishments of individual rights is difficult. Common ownership is the fundamental fact affecting almost all regime of fishery management.

### **Territorial Use Rights in Fisheries (TURFs)**

The concept of tenurial rights such as TURF has long been existing specially in terrestrial resources. It is easier to imagine tenurial use rights among herders in a piece of land than TURFs among fishers because of the three-dimensional feature of the marine resources where stocks such as fish migrate from one place to another. TURFs deals on the ownership of the right to use rather the ownership of the resource.

In order for TURFs to be effective, there are certain kind of rights that need to be exercised: (1) the right of exclusion or right to limit or control access to the territory; (2) right to determine the amount and kind of use within the territory; (3) right to extract benefits from the use of the resources within the territory; and (4) right to future returns from the use of territory (Christy, 1982).

The right of exclusion or to limit access to the resource removes to a certain degree the condition of common property. Control over the resource, however, is not absolute. For example, the flow of nutrients or even pollutants to a territory is difficult to control in a marine resource. TURF is more site specific than resource specific.

The right to determine the amount and kind of use within the territory neutralizes the effect of overfishing that can occur in a common property resource. The right to extract benefits from the resource are the returns on the investment (capital) or returns on labor. It can also mean non-monetary benefits such as enjoyment on the use of the resource.

The right to future benefit is very important in the implementation of a sustainable fishery resource management regime since it assures resource users that benefits will continuously flow now and in the future. An example of a fishery management regime is “closed season to give “breathing time” for the resource to recover on the premise that the future benefits will be enjoyed by the fishers.

The tenure of localized TURFs for fisherfolk must therefore be in perpetuity in order to ensure compliance on the rules and rights in TURFs not only in the present but also in the future.

Our concern in the adoption of TURFs as Fishery management strategy is more on the localized TURFs (fishing communities) rather than generalized TURFs such as extended economic zone (EEZ). The area covered by TURFs for a fishing community should be big enough so that the use of the resource outside the territory will not diminish the use inside the TURFs area. The area may include the surface, bottom, or the entire water column which will include sedentary and migratory species within the territory. It is advisable to put boundary markers but not to enclose the area which will prevent the natural flow of water affecting other resource users outside the TURFs area. Besides, it can be expensive and not practicable.

In the use and management of a TURFs, the users (preferably organized fisherfolk) have the right to determine the objectives being sought from the use of the territory. Because of this right, the organized fisherfolk will have the opportunity and sufficient incentives to manage the resource within the territory. The concept of a community-based coastal resource management, (CBCRM) then becomes an effective overall strategy of managing common pool of resources.

In study of five fisherfolk communities in the provinces of Iloilo, Antique and Guimaras, the fisherfolk-respondents perceived that TURFs are beneficial to them (Siar, et.al. 1993).

### *Conditions for an Effective TURFs*

#### A. Natural Resource Attributes

The biophysical attributes of the resource must be considered in order to fully enjoy its benefits. Areas with sedentary species (shellfishes, invertebrates) and other site-attached or associated species (those that depend on natural and artificial reefs) are good sites for TURFs. Suitable sites for cage culture can also be considered as a good TURF area. An area which is considered as a “route” of migratory species can also be considered as TURF area,

#### B. Boundaries

Setting of boundaries to accurately define the territoriality of the TURFs area is critical in the implementation of the rules and rights set by fisherfolk community. It also makes surveillance and monitoring of the territory easier. It will prevent conflicts with other resource users and stakeholders.

### **Community-based resource management**

Community-based coastal resource management or CBCRM and co-management strategies have been successfully implemented in the Philippines (Pomeroy and Carlos, 1997; Agbayani and Babol, 1997; Primavera and Agbayani, 1996). The people-centered approach of CBCRM focuses on capacitating the fishing community through training, education and skills development in the resource management, enterprise development, training on paralegal issues, gender sensitivity, and lobbying among others. These people-empowering activities have prepared the community to be effective and active co-managers of coastal resources. Community-initiated institutional arrangements on marine sanctuaries and reserves have also been implemented in various fishing communities in the Philippines. The concept of territorial use- rights in fisheries (TURFs) which grants the organized community property rights over coastal resources has been encouraged and legitimized by the government through existing laws, such as the Local Government Code of 1991 and the Fisheries Code of 1998. In mangrove forests, Administrative Order No. 15 (1990) of the DENR or the Department of Environment and Natural Resources sets aside public forests as “communal mangrove forest” for the exclusive use of residents of the municipality from which said residents may cut, collect, remove mangrove forest products, such as firewood and mangrove timber for charcoal production for home consumption in accordance with forest laws and regulations.

Community-based strategies are effective in addressing localized problems through localized solutions especially those pertaining to the exploitation of common property resources. External agents, e.g., NGOs, academic and research institutions, government agencies, have predominantly initiated CBCRM activities. The relationship of these external agents to the community, however, should be temporary until the community has developed a sense of preparedness and self-reliance.

Beyond the community-based initiatives, however, will be the bigger issue of legitimizing locally-accepted institutional arrangements by concerned government agencies. This act of delegating authority to the community to use and manage coastal resources is a co-management arrangement between the government and the local community. The process of co-management involves participation in decision-making, power sharing, and conflict management.

### **Co-management**

The focus of co-management is the issue of property rights or rights to access and limit other users from the resource. Co-management addresses the issue on ownership of resource and mechanism to allocate use rights through rules and regulations. However, to date, literature in mangrove utilization in the country has limited, if any, documentation on informal or customary use-rights appropriation – of their construction, logic and historical transformation. There is a need to look into the social circumstances of the actors because as their circumstance change, so does the



organizational structure of the community. Failures to recognize this aspect would eventually result in resource-use conflict (Cordell, 1992), unsustainable practices and inequitable distribution of benefits (Ruddle, 1994), considering the multiple-use characteristic of this resource.

There is a need to examine and evaluate property rights and collective action on mangrove ecosystems to provide reliable scientific information for policy formation. Considering the vast mangrove resources that have been destroyed, and are presently being converted to different uses, there is a need to rationalize development strategies that will ensure efficiency, equity and sustainability. Poverty and food security are the burning issues confronting developing countries today.

There is a need to balance environmental conservation and food security in the management of coastal resources. Sustainable aquaculture technologies are being tested, verified, and transferred for adoption by fishing communities in the Philippines, Vietnam, Indonesia, and other Southeast Asian countries. During the Workshop on Mangrove-Friendly Aquaculture recently implemented by the SEAFDEC Aquaculture Department and funded by the Japanese Government Trust Fund, in Iloilo City, Philippines participants defined mangrove-friendly aquaculture as; (1) benign; harmonious existence between fisheries and mangrove resources; (2) beneficial to the community and economically viable; (3) enhances biodiversity with minimal impact on the environment; and (4) integrates mangrove rehabilitation and protection with food-producing activities such as aquaculture.



## UNDERSTANDING COMMUNITY-BASED AQUACULTURE THROUGH PARTICIPATORY APPROACHES

*Renato F. Agbayani*  
*Head, Training and Information Division,*  
*SEAFDEC/AQD, Tigbauan, Iloilo, Philippines*

### INTRODUCTION

A comprehensive analysis of village conditions will require sufficient time and resources. More often, there is not much time and resources in doing social analysis of the conditions of a community for effective community-based natural resource management. In view of this, there has been growing interest in doing rapid and participatory appraisal of rural communities for collaborative decision-making purposes.

The use of Rapid Rural Appraisal (RRA) is a research tool that is cost-effective, timely, and analytic. Rural communities throughout the world are experiencing high rates of changes in terms of life styles including the need for knowledge and updated information, training, and skills. Information change rapidly and therefore there is a need to keep up with knowledge rapidly. RRA is a tool of learning from people in order that any development intervention that will be introduced in the community will address the aspirations of the people. RRA has been developed for and can be used to generating general information on various variables, whether physical structures (farms, houses, and machines) or services such as social organization and political structures.

Participatory Rapid Appraisal (PRA) methods have evolved from Rapid Rural Appraisal (RRA). PRA emphasizes the processes which empower local people, whereas RRA is mainly seen as a means for outsiders to gather information. PRA is an approach to the analysis of local problems and the formulation of tentative solutions with local stakeholders. It makes use of a wide range of visualization methods for group-based analysis to deal with spatial and temporal aspects of social and environmental problems. It mainly deals with a community-level scale of analysis but is increasingly being used to help deal with higher level, systemic problems.

### BASIC PRINCIPLES OF PRA

**1. Participation** – Inputs from the community into PRA activities is important to its value as a research and planning method. Participation improves chances of better collective efforts of the members of the community whether in conserving the common resources or in undertaking livelihood activities that uses the natural resources such as aquatic, land and forest.

There are advantages of using participatory approaches for rural development such as :

- increased “sense of ownership” of the project or activity;
- improved productivity and efficiency
- increased coverage of impacts;
- increase equity and self-determination;
- increased likelihood of the project continuation, maintenance as sustainability after project completion;
- increased cost-sharing and effectiveness; increased of appropriateness and relevance of the community development activity;
- fulfillment of basic needs

**2. Teamwork.** The PRA team should be well-balanced that it represents different but complementing and interacting disciplines in socioeconomics, culture, gender, technology, and generational perspectives. PRA is best done by a team that includes local people with perspective and knowledge of the area's conditions, traditions, and social structure and either nationals or



expatriates with a complementary mix of disciplinary backgrounds and experience. Ideally, the team should include a socio-economist, social worker, scientist (biologist, aquaculturists), technologist, policy researcher etc. Close and continuous coordination among the team members is necessary to understand the complexities of the factors affecting the success of the project on rural development.

**3. Flexibility.** PRA is a learning process and as such does not provide straight-forward procedures and protocols in dealing with a community. The PRA approach is flexible and uses a combination of techniques that is appropriate in a particular development context determined by variables as the size and skill mix of the PRA team, the time and resources available, and the topic and location of the work.

**4. Optimal ignorance.** This refers to knowing what is not worth knowing. To be efficient in terms of both time and money, PRA work intends to gather just enough information to make the necessary recommendations and decisions.

**5. Triangulation.** Learning from different perspectives and disciplines (at least three) is a feature of PRA. PRA explicitly seeks insights from and an understanding of the needs of different individuals and groups, which may be conflicting but will better show the complexity of local situations. PRA works with qualitative data. To ensure that information is valid and reliable, PRA teams follow the rule of thumb that at least three sources must be consulted or techniques must be used to investigate the same topics.

## PRA TOOLS

PRA is an exercise in communication and transfer of knowledge. PRA employs a wide range of methods to enable people to express and share information, and to stimulate discussion and analysis. The learning-by-doing and teamwork spirit of PRA requires transparent procedures. For that reason, a series of open meetings (an initial open meeting, final meeting, and follow-up meeting) generally frame the sequence of PRA activities. Other selected tools common in PRA are:

### 1. Group methods:

#### *Focus Group Discussion (FGD)*

- a. FGD is discussion with selected group of four to eight community members to: i) generate information, build consensus, clarify information in documents; gather different opinions on certain issues that are lacking in details from other sources; ii) gather information on specific issues such as pollution of aquatic resources, livelihood options, socioeconomic conditions, and regulations on the use of common resources;
- b. Guidelines in designing FGDs:
  - i) Guidelines are open-ended questions by the facilitator to encourage discussion on specific issues and expression of ideas, opinion, and experiences.
  - ii) Questions are phrased in such a manner that will discover attitudes and practices in a general way.
  - iii) Guidelines should be brief
  - iv) Guidelines should provide only the opening questions and a reminder of other related issues.
- c. Outputs
  - i) Information can be used for planning, strategizing of competing profile of the community or the resource.
  - ii) Consensus or agreements on controversial issues.
  - iii) General perception of community members on important matters.

### *Brainstorming*

- a. Brainstorming is sharing of ideas on specific issues or concerns. It encourages critic and creative thinking among the group members to understand problems and recommend solutions.
- b. Guidelines or approaches:
  - i) Set the objectives of the activity
  - ii) Determine the individuals of groups that will be involved
  - iii) Inform and discuss with community leaders details of activity and let them identify participants
  - iv) Set time, date and place of brainstorming
- c. Outputs - A set of new ideas and ways of looking at a topic. Ideas may be classified, segregated or synthesized

## **2. Surveys**

- a. Key informants identification is purposely selected community members who are able to provide the needed information. Individuals with experience on the particular concerns should be selected.
- b. Semi-structure interview is conversation with a purpose. It involves a set of guidelines or discussion points. As the interview goes along, the facilitator can raise new questions on matters that arise during the interview. Information is not limited to the set of guide questions prepared by the facilitator.
- c. Semi-structure interview is a way of generating information by providing opportunity to probe the answers of the respondents, discuss new issues that may arise during the interview and get clear and accurate answers on the personal experiences of the respondents.
- d. The types of question asked are: i) descriptive; ii) structural; iii) contrast (comparison); and, iv) probing (deeper questions).
- e. Group interviews are advantageous. The group can have more control over the discussion and provide opportunity for dialogue among the participants.

## **3. Mapping**

- a. Village transects – series of observations while walking in a village. The transect method allows direct observation and cross check of information previously gathered in the community. It allows a friendly atmosphere with the respondents because of the informal approach and interaction. The transect method provides opportunities to get sensitive issues (illegal fishing etc) that may not be gathered in formal settings.

The types of information gathered using the transect methods are classified as follows:

- i) Bio-physical – topography, hydrology, soil type, geology, forestry, agriculture, aquatic resources. Environmental conditions (erosions, cutting of mangroves etc) can also be observed and recorded. Endangered species (sea grass beds) can also be observed.
  - ii) Resource use can also be observed such types of agriculture, aquaculture systems, plants that are used by the community etc.
  - iii) Socioeconomic conditions of the community can easily be observed in terms of types of houses, fishing gears, livelihood activities as well as sanitary facilities (water, toilet etc).
- b. Resource mapping – method of collating and plotting information that allows the
  - c. Researchers and community members to identify, locate and classify past and present resource occurrence, distribution, use and tenure on the occurrence of resources in a community. It shows the relation between information set and its location to establish visual relations between resources and use or issues. Resource mapping is also a complementary tool in doing village transects.

Some of the resources or issues that can be reflected in a resource map are:

- i) habitats i.e. mangroves, coral reefs, sea grass beds, wetlands, forest, rivers etc
- ii) aquaculture areas; fishing grounds
- iii) breeding grounds, migration routes

- iv) resource use (agriculture, fish culture, livestock etc)
- v) resource access, limitations and conflicts
- vi) use rights and tenure

The map reflects the perception and vision of the participants about the resources. It provides visual representation and use of resources.

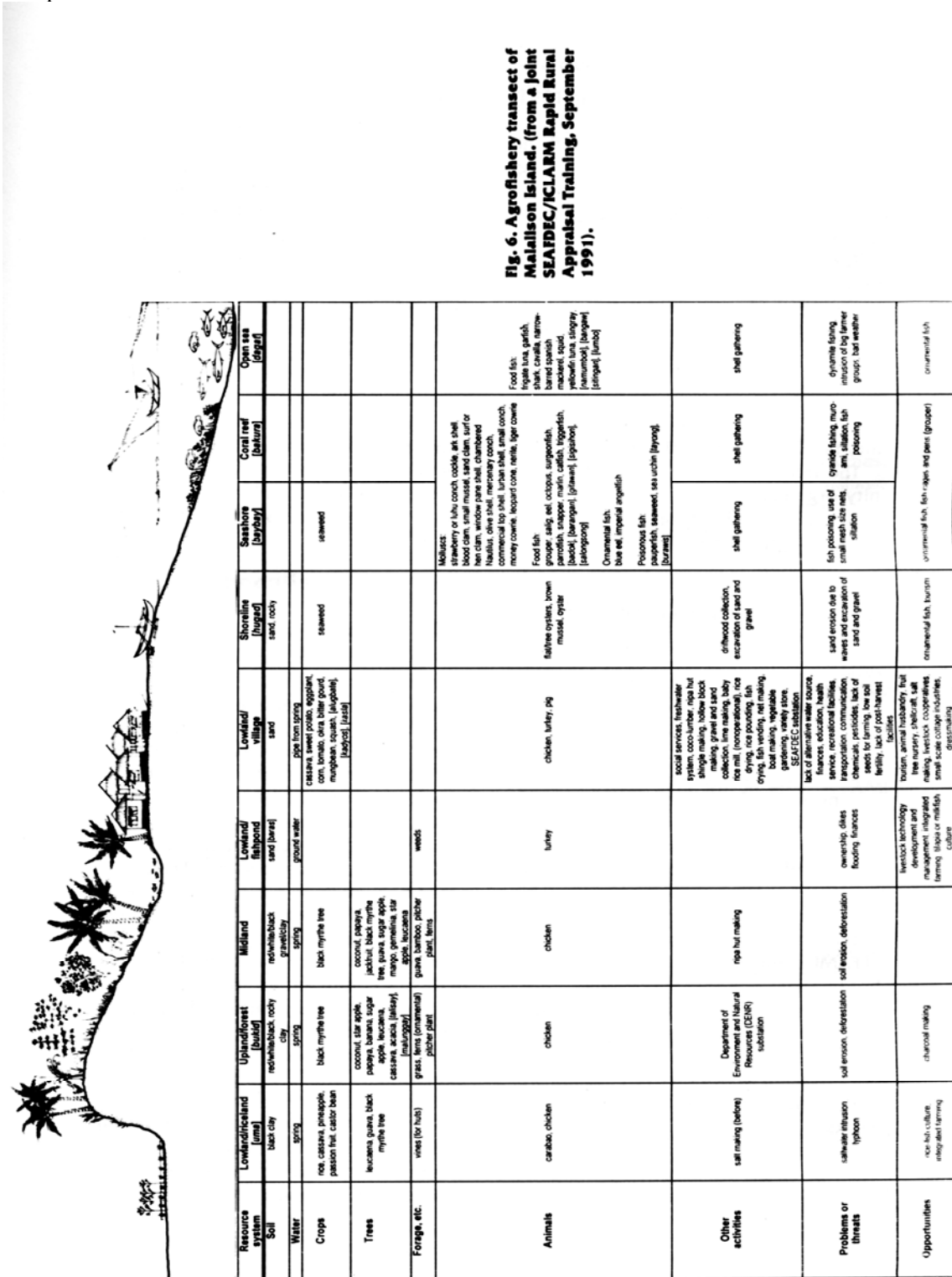

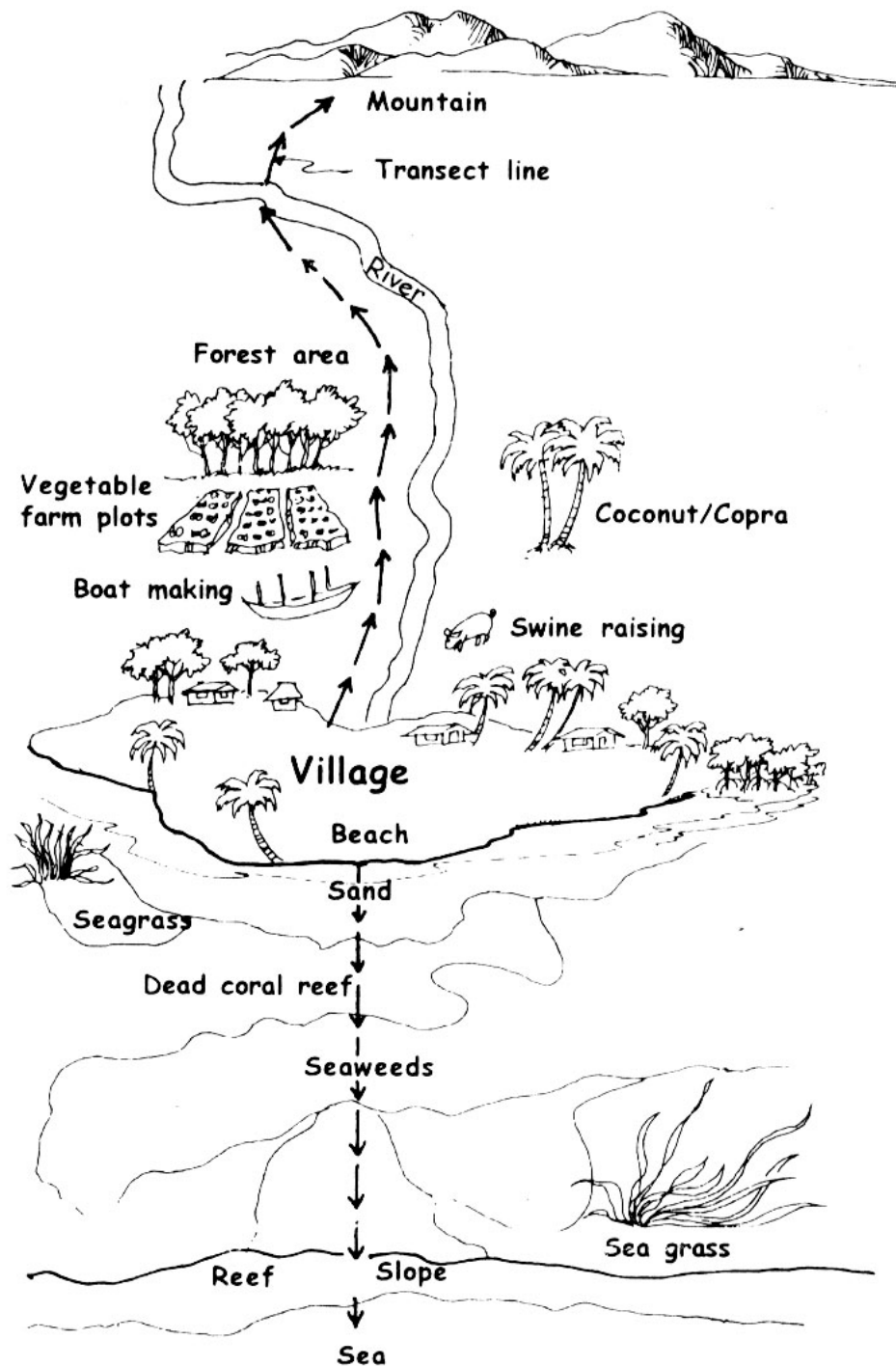

- i) like typhoons or drought;
  - ii) fishing and fish activities (daily, lunar days, stocking, feeding, harvesting, illegal fish activities such as use of dynamite, cyanide)
- social and political activities (parties, electio

#### 4. Activity calendars

- a. Seasonal calendar - shows the weather, social activities, economic activities, and other important occurrences (diseases, school activities)

The activities and events that could be used are:

- iii) environmental conditions – weather
- iv) n, religious etc)
- v) other livelihood activities (carpentry, trading etc)



- b. Daily activity – a tool in recording and knowing the daily activities of the respondents both productive and reproductive, including community activities and social activities. This is helpful in preparing seasonal calendars and historical timeline. It also identifies the daily activities of the different sectors of the community such as fishermen, women, children etc. This is a useful tool in determining whether a community member can participate in a cooperative activity such as aquaculture livelihood and coastal resources management.

The output of this exercise is a visual representation of typical daily activities of a member of a community. It also provides information on how the different segments of the community use and management their time.

### Sample output



### 5. Problem tree analysis

Problem tree analysis is a tool in project planning also called situation analysis. It looks into the causes of a central problem and the effects or consequences in the target community where a project is being planned.

Here are some of the advantages of this tool:

- a. Real and present issues are identified and dealt with;
- b. The problem can be broken down into manageable components which enable a clearer prioritization of issues that has to be addressed in the planning and implementation of a project.
- c. There is a better understanding of the problems because of the interconnectedness of cause and effects.
- d. It identifies the issues and arguments of the constituents and establishes who are the main players and political actors and processes in each stage.

- e. It can establish what further information, evidence or resources are needed to make a strong recommendation or actions to be taken.
- f. The process of analysis often helps build a shared sense of understanding, purpose and action.

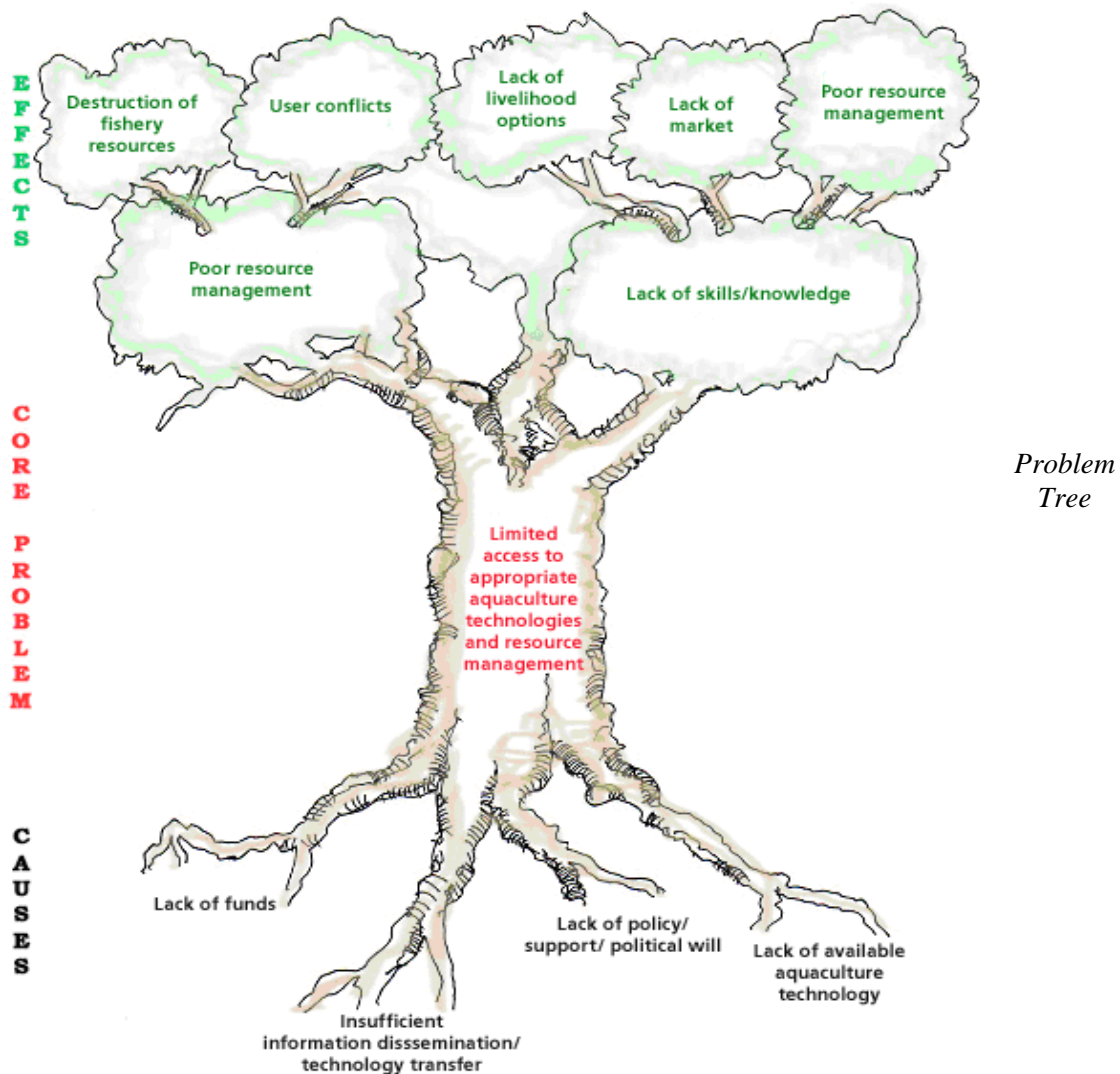

*Analysis: Antique Province*

## ORGANIZING PRA

A typical PRA team includes the facilitator (team coordinator or leader), interdisciplinary researchers, and representatives from the community for two to three weeks on workshop discussions, analyses, and fieldwork. Several organizational aspects should be considered:

1. Logistical arrangements should consider nearby accommodations, food, sufficient vehicles, field notebooks, portable computers, supplies such as flip chart paper and markers.
2. Training of team members may be required.
3. PRA results are influenced by the length of time allowed to conduct the exercise, scheduling and assignment of report writing, and critical analysis of all data, conclusions, and recommendations.
4. A PRA covering relatively few topics in a small area (perhaps two to four communities) should take between ten days and four weeks, but a PRA with a wider scope over a larger area can take several months. Allow 2-3 days for an introductory workshop if training is involved.



- Field work reports are best written immediately. A preliminary report should be available within a week or so of the fieldwork, and the final report should be made available to all participants and the local institutions that were involved.

### SEQUENCE OF TECHNIQUES

PRA techniques can be combined in a number of different ways, depending on the topic under investigation. Some general rules of thumb, however, are useful. Mapping and modeling are good techniques to start with because they involve several people, stimulate much discussion and enthusiasm, provide the PRA team with an overview of the area, and deal with non-controversial information. Maps and models may lead to transect walks, perhaps accompanied by some of the people who have constructed the map. Wealth ranking is best done later in a PRA, once a degree of rapport has been established, given the relative sensitivity of this information.

The current situation can be shown using maps and models, but subsequent seasonal and historical diagramming exercises can reveal changes and trends, throughout a single year or over several years. Preference ranking is a good icebreaker at the beginning of a group interview and helps focus the discussion. Later, individual interviews can follow up on the different preferences among the group members and the reasons for these differences.

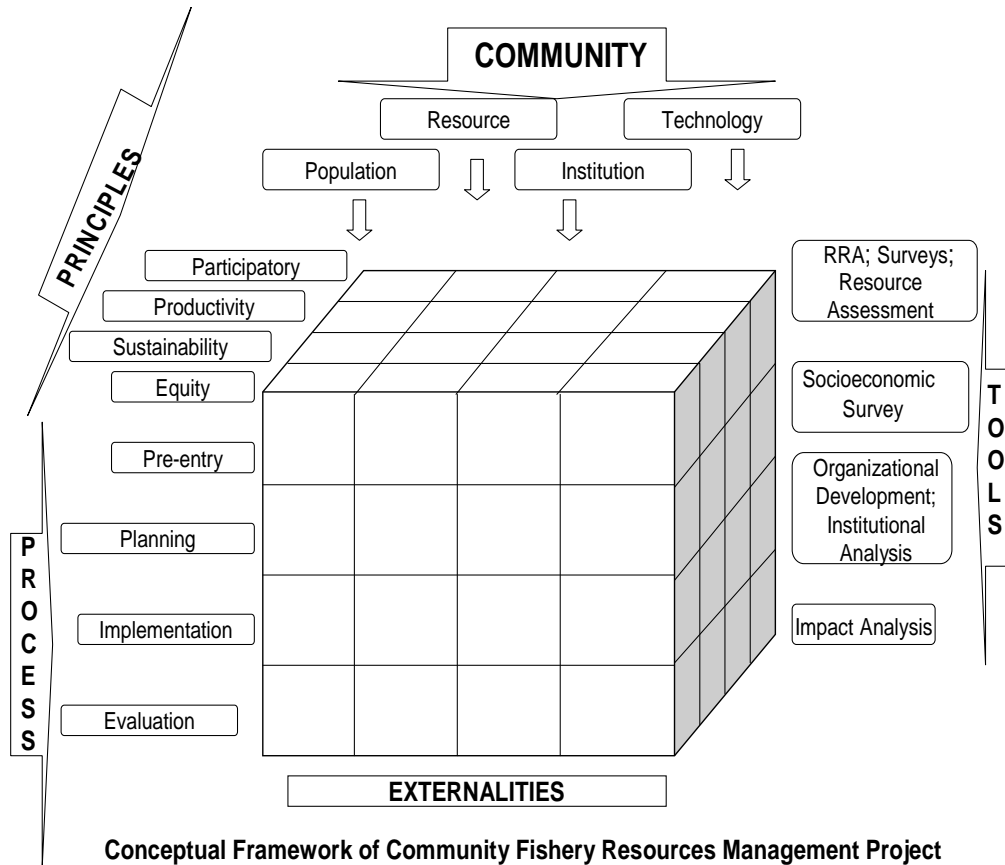



## **TECHNOLOGY TRANSFER OF AQUACULTURE TECHNOLOGIES: FRAMEWORK AND STRATEGIES**

*Renato F. Agbayani  
Neila Sumagaysay-Chavoso  
Joebert D. Toledo  
SEAFDEC Aquaculture Department  
Tigbauan, Iloilo, Philippines*

### **INTRODUCTION**

#### **Aquaculture: fastest growing food production system**

All over the world, aquaculture has been the fastest growing food production system for almost two decades now. Aquaculture provides 43% of the fish consumed worldwide (FAO 2006). The growing dependence on aquaculture to fill the increasing demand for fish is due to dwindling catch from the wild. Many developing countries, especially in Southeast Asia, look upon aquaculture to help address food and livelihood problems. To promote the development of aquaculture, governments have invested on aquaculture research and development (R&D), provided tax incentives to companies that are engaged in aquaculture and related enterprises, and formulated policies in support of aquaculture and aquaculture-related industries.

#### **Aquaculture: boon or bane?**

Aquaculture boom has become both a boon and a bane to fish-producing countries. Fish export, mainly from aquaculture produce, is a major source of foreign currency for developing countries in Southeast Asia. Aquaculture produce, e.g. tilapia and milkfish, has stabilized fish prices by providing abundant alternative to the preferred-but-increasingly-costly wild-caught fish. Aquaculture enterprises and aquaculture products processing have provided employment for people in both rural and urban areas, and have significantly contributed to government revenues.

On the other hand, aquaculture has been blamed for the destruction of natural resources such as mangroves, seagrasses, and coral reefs. Over-pumping of fresh water to support aquaculture operations has caused ground subsidence and the intrusion of saltwater into freshwater tables. There are also claims that only the rich investors have benefited from the aquaculture production and export. Small-scale fishers have been further marginalized by the destruction of aquatic resources that are the main source of their food and livelihood.

#### **SEAFDEC /AQD: R&D for sustainable aquaculture**

Since the 1990s, research efforts throughout the world have focused on developing environment-friendly culture systems, or techniques for sustainable aquaculture. FAO defines sustainable aquaculture as the management and conservation of the natural resource base and the orientation of technological and institutional change in such a manner as to ensure the attainment and continued satisfaction of human needs for present and future generations. Sustainable aquaculture conserves land, water, plant and animal genetic resources; it is environmentally non-degrading, technically appropriate, economically viable, and socially acceptable.

The Southeast Asian Fisheries Development Center Aquaculture Department (SEAFDEC/AQD) is mandated to promote and undertake aquaculture research and development relevant to Southeast Asia, develop researchers, train technicians and resource managers, and collect, disseminate and exchange information. To accomplish these goals, SEAFDEC/AQD drew up a conceptual framework for its R&D that provides a continuum of activities from research and technology generation to training and information dissemination and impact assessment.

## SEAFDEC/AQD RESEARCH & DEVELOPMENT FRAMEWORK

Aquaculture research and development is a cycle of activities (Fig. 1). It is founded on strong collaboration among the various stakeholders - policy makers, scientists and technologists, private businessmen and fishers/fishfarmers, teachers and students, and the general public.

Scientific research is the foundation of technology generation. Sound research provides accurate and consistent bases for determining problems areas, methods of problem analysis, and generation of verifiable data and information for problem solving. SEAFDEC/AQD researchers adhere to the “publish or perish” tenet. They write the results of their research projects, submit their manuscripts to Institute for Scientific Information journals that will subject them to review by respected experts from all over the world before they are accepted for publication. Peer review of manuscripts - the evaluation of the soundness of the research methods, analysis and presentation of results - motivate researchers to conduct relevant research and write manuscripts that meet standards of international experts.

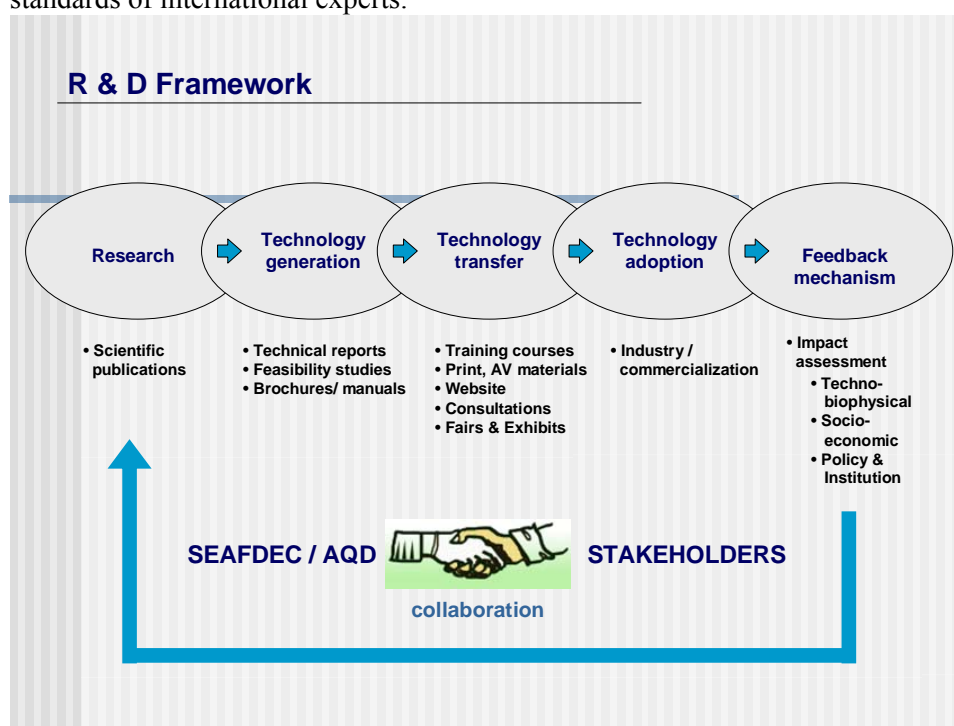

Figure 1. SEAFDEC R&D Conceptual Framework

At SEAFDEC AQD, the scientific publication is not the end of the researchers' work. It is, in fact, the start of the process of informing the general public about the significance of the knowledge generated from research as an important input to technology generation.

The primary information contained in a scientific publication has to be tested and verified in an economic scale to evaluate the financial viability and technical feasibility. Trial runs using statistically accepted methods (time and space) are done in different aquatic environments (freshwater, brackish water and marine waters) using different culture systems (breeding and hatchery, pond, cage and pen, sea farming and sea ranching systems). Depending on the results of the run - in terms of production and farm economic indicators - trial runs in commercial scale are done in demonstration farms in collaboration with private operators, schools and organized fisherfolk organizations. Popular publications, e.g. operating manuals, brochures, flyers, audio-visual materials, are produced for wider circulation to the private sector, fisherfolk organizations and other stakeholders.

The impacts of the aquaculture technologies are assessed in terms of the techno-bio-physical sustainability, social and economic acceptability, and policy and institutional arrangements in the transfer and adoption by the stakeholders. The impacts of the aquaculture technologies will be subjected to further studies to ensure that they conform to standards set for aquaculture sustainability.

## **STAKEHOLDERS, TECHNOLOGY TRANSFER PATHWAYS AND STRATEGIES**

### **Four Levels of Stakeholders/Cientele**

There are four levels of stakeholders that are the target recipients of SEAFDEC/AQD's "research products" or technologies and knowledge generated from research.

The first level of clientele/stakeholders consists of officials in the policy-making and planning bodies of the government, national and international fisheries research organizations, and funding agencies. These are the people who make policies, or who influence policy-making, related to fisheries resources management. Researchers provide them with policy papers or briefs to guide them in their preparation of policies and enactment of laws. Recipient government agencies are the Bureau of Fisheries, Department of Agriculture, Department of Environment and Natural Resources and local government units. Recipient international organizations include SEAFDEC's Secretariat, the fisheries agencies of the 11 member-countries of SEAFDEC, the WorldFish Center, and the UN Food and Agriculture Organization (FAO).

The second level of stakeholders is composed of researchers of R&D institutions and academe, and development workers of non-government organizations. Their primary interests are the scientific methodologies and analytical tools used in the conduct of research, whether bio-physical, socioeconomic or policy-related. In the Philippines, some of these institutions are the University of the Philippines, Mindanao State University, Central Luzon State University, Palawan State University, Bicol State University, National Fisheries Research and Development Institute, and schools of fisheries. The main research products given them are publications in primary journals and proceedings in scientific conferences.

From 1976 to December 2006, SEAFDEC/AQD has produced 1,223 publications, broken down into: international journals (50%), conference proceedings (33%), and other journals (17%). SEAFDEC AQD is strongest in this level in view of the many scientific publications that have been cited by other scientists doing research in the fields of fisheries and aquaculture, marine biology, socioeconomics and policy related to fisheries and aquaculture.

The third level of stakeholders consists of officers and staff of "on-the-ground" institutions, such as local government units (LGUs) and regional government agencies, community-based organizations, local non-government organizations (NGOs) and fishery schools. They are the front liners in the management and regulation of fisheries and aquaculture resources and environment and, therefore, need relevant and updated scientific information pertaining to aquaculture technologies and coastal resources management. Unfortunately, the reality is that they are the weakest link in the management and conservation of aquaculture resources and environment due to lack of support in terms of technology, logistics, financing, and capacity-building.

The fourth level of stakeholders is the internal staff of AQD and other SEAFDEC departments in Thailand, Singapore and Malaysia. Information exchange among the departments, divisions, and section in the organization is vital since the internal staff are the agents of information who cater to the general public.

## Technology Transfer Pathways

Figure 2 shows the technology transfer pathways, or the distribution and dissemination channels of the communication products leading to the various clientele/stakeholders of SEAFDEC/AQD. The various research products (policy briefs, technical reports, journal publications, posters, audio/video clips, etc) are delivered through one or a combination of various delivery systems. The delivery systems will depend on the information materials and the target audience. The multi-media mix, such as print, radio, television and Internet, has been used in disseminating research information. The Internet has been an effective tool for information dissemination because most of the information materials are downloadable. Interpersonal communications, such as policy briefings and consultations, scientific forums, training courses, and extension activities have been effective in transferring information and technologies for aquaculture and fishery resources management. Researchers and research products end-users are able to discuss various issues pertaining to technologies, technology transfer and adoption, economics and marketing, and policy matters.

At the end of the technology transfer pathway, impact assessments are conducted covering the technological-bio-physical factors, socioeconomic conditions, and environmental changes that occurred as a result of technology transfer and adoption. Impacts may come in the form of improved and more effective ordinances and regulation in resource management in the municipal levels; improved productivity of aquaculture farms, and the resulting increase in the income of the fish farmers; and improved general well-being of aquatic resources like mangrove forests, seagrasses, and coral reefs. Overall, impact assessment aims to produce a better informed and enlightened citizenry who are empowered to manage and conserve their resources for sustainable development.

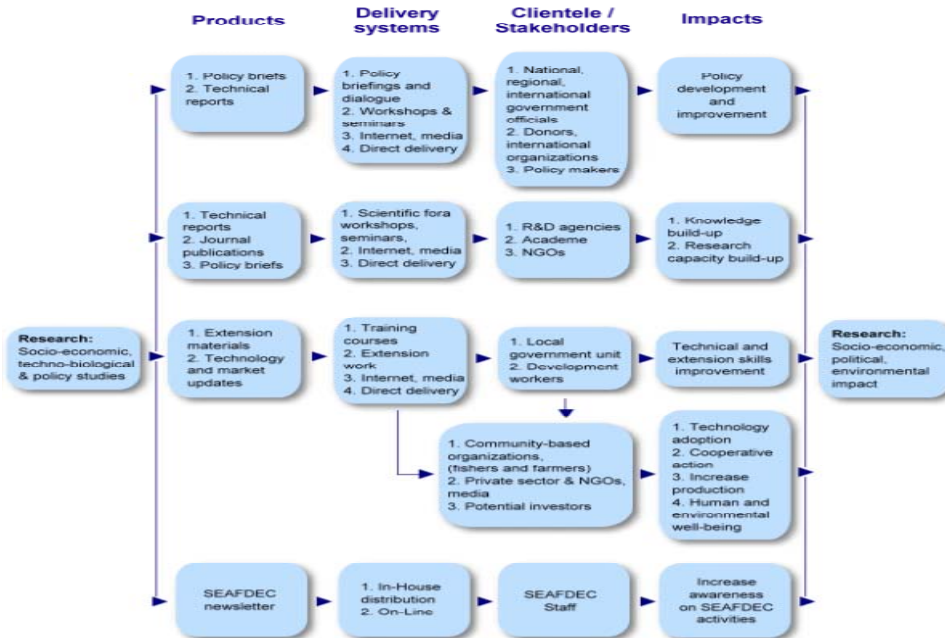

Figure 2. Technology Transfer Pathways

## Research Products

There has been a great waste of research funds, dwindling as they are, because of the lack of policies and mechanisms for the dissemination of valuable information generated by research. The results of a research project undergo some “processing and packaging” in order to convert them into appropriate forms or products (journal publications, policy papers, brochures, audio/video clips, etc) and languages (scientific, technical, layman) that will be easily understood by the intended users. For the research product to be acceptable and useful, it is important to tailor them according to the characteristics, idiosyncrasies and location of the users.

The following are the main research products of SEAFDEC/AQD:

### 1. Scientific publications

Journal publications are the standard media for disseminating primary information from research. Internationally recognized experts evaluate the manuscripts that are submitted for publication to ensure high quality and integrity of the science of the paper. SEAFDEC AQD researchers have published 611 papers in international journals, 208 papers in local journals, and 404 papers in international conference proceedings.

### 2. Policy papers

SEAFDEC/AQD’s scientific publications are cited in the two most important policy papers governing fisheries in Southeast Asia: Code of Conduct of Responsible Fisheries, Regional Guidelines in Responsible Aquaculture (Department of Agriculture, 1998) and Code of Practice for Sustainable Use of Mangrove Ecosystems for Aquaculture in Southeast Asia. Policy papers are necessarily prepared by interdisciplinary team of researchers because of the cross-sectional implications of policies. Policy briefs are prepared for extremely busy target readers of policy papers, such as lawmakers, and government program planners and technocrats. Policy briefs are written in concise and direct-to-the-point language.

### 3. Manuals, handbooks, brochures and flyers

The information contained in manuals, brochures and flyers are generally extracted from scientific publications and technical reports. The contents of these information materials are technology tips and "how-to's," market updates, and general information on aquaculture technology, aquatic resources, and government policies. SEAFDEC/AQD has produced 79 aquaculture extension manuals, monographs, brochures and flyers that have been sold or distributed for free.

### 4. Magazines and newspapers, and industry newsletters

Research results that are deemed of interest to the general public are written “feature style” for publication in newspapers, magazines and industry newsletters. Feature articles are written either by SEAFDEC/AQD staff or by newspaper/magazine correspondents who are given information to flesh out.

Since 1979, SEAFDEC/AQD has produced 660 newsletters, 131 magazines (SEAFDEC Asian Aquaculture) for international distribution, and 52 aquaculture farming news on technology updates.

### 5. Audio-visual aids: video/audio clips, tapes and CDs

Audio/video clips, tapes and CDs contain documentaries and instructions and demonstrations that are shown for the benefit of SEAFDEC/AQD visitors and trainees. Fishery schools usually buy these products for classroom use. SEAFDEC/AQD has produced and distributed 62 audio-visual products on culture systems of various species like milkfish and grouper and on community fisheries resources management.

## Delivery Systems

Effective information dissemination and technology transfer do not depend solely on the quality and relevance of the research products. Good information and knowledge are wasted unless they reach the users in the right place, at the right time, and at the right price. It is important to have in place effective and cost-efficient delivery systems to reach out to various users of information and technology.

### 1. Multi-media mix strategy

SEAFDEC/AQD uses a variety of delivery systems to reach different stakeholders, namely: a) multi-media, e.g. print, radio and television; b) website; and c) interpersonal communication. Print media includes national and local dailies and magazines that feature stories about SEAFDEC activities (training courses, technology updates, field projects.) Local radio is used to reach out to fisherfolk and community organizations. Radio is an effective medium for the exchange of ideas about fishery resources management strategies as it encourages debate among resource users (fishers, aquaculturists, policy makers, and law enforcers). Television is effective in showing visually the “how-to’s” of aquaculture and the adverse effects of illegal fishing and certain aquaculture practices.

### 2. Website

The webpage of SEAFDEC [www.seafdec.org.ph](http://www.seafdec.org.ph) is optimally used in disseminating research information. Most of SEAFDEC/AQD’s publics – researchers, students and academicians, government policymakers and decision-makers, fund donors, and collaborators - have access to the Internet. The SEAFDEC/AQD website is updated regularly and contains materials that are downloadable by clients from all over the world.

### 3. Interpersonal communication

Interpersonal communication, such as policy dialogues, village general assemblies, training and field extension, is a very effective way of reaching out to various publics because it is interactive and it gives the audience the opportunity to verify information personally. This approach was extensively used by SEAFDEC/AQD in the implementation of its Community-based Fishery Resource Management project on Malalison Island, Culasi, Antique province (Agbayani et al, 2000) in 1991-98. In this project, researchers and development workers effectively made use of general assemblies to dialogue with the Malalison fisherfolk, their leaders and local government officials. The general assemblies gave researchers and development workers opportunities to explain information, and clarify issues and concerns in layman and easy-to-understand language that could be understood by the villagers who generally had low educational attainment. Feedback about the project was obtained firsthand, and responded to immediately.

## Training

On-site and hands-on training courses have been conducted by SEAFDEC/AQD since 1977. They were attended by government fisheries personnel, academics, entrepreneurs and fish farmers from SEAFDEC member-countries, as well as from countries in South Asia, Asia-Pacific, South America and the Middle East. Special courses have been designed to suit the needs of requesting agencies. Most of the lecturers and practicum instructors in these training courses are AQD’s own researchers and technicians.

SEAFDEC/AQD continues to widen and add to its information delivery systems. In 2002, it opened its first Internet-based distance learning course on the Principles of Health Management in Aquaculture. In 2001, it embarked on textbook writing upon the request of fisheries schools. It has produced two books: one on fish health management, and the other on tropical fish nutrition.

A recent innovation in the training methodology of SEAFDEC/AQD is the season-long training course. This is done in collaboration with long-term projects of local government units and fishery



schools. This course is a combination of lecture (2-3 days) and monthly hands-on monitoring, including on-farm discussion and analysis of problems and concerns, such as disease detection and feed formulation. The last session of the season-long training course is the actual harvest of fish in the fish farm. The training course lasts 4-5 months. The lecture topics include principles, concepts, technical and socioeconomic aspects of sustainable aquaculture. The language used is a combination of English, Filipino and the local dialects.

All training courses include lectures on the principles and concepts of sustainable aquaculture and aquatic resources management. Training courses on community-based coastal resources management give emphasis on sustainability issues like environment conservation, socioeconomic acceptability and policy implications of the resource management strategies.

### **Library and FishWorld Museum**

Established in 1975, the SEAFDEC/AQD Library has accumulated the biggest collection of aquaculture literature in Southeast Asia. Besides the SEAFDEC/AQD researchers and staff, Library users include students and faculty members of fishery schools and the general public. The Library also serves requests (by phone, letter, fax or email) for information and materials from clients outside the country.

The prized collections of the AQD Library are literature on brackishwater species, abalone, grouper, milkfish, mudcrab, rabbitfish, seabass, seaweeds, tiger shrimp, freshwater prawn and tilapia. It also has an impressive collection of Filipiniana materials.

The library collection - 34,734 titles and 53,911 volumes/copies as of December 2006 - is in electronic databases that can be searched through the AQD website under the online-public-access-catalogue.

FishWorld is AQD's museum-aquarium and visitor center. Established in July 2000, it is dedicated to science and environment education of the general public, especially about aquatic ecosystems and biodiversity, fisheries, and aquaculture. It has become a must-see for school field trips and tourists. The Aquaculture Week hosted by FishWorld is annual event of SEAFDEC/AQD's environment education program. It is participated by students and teachers from elementary and secondary schools and learn about aquaculture and the environment through competitions in science, art, writing and livelihood projects. The FishWorld museum has a collection of about 3,000 species of fishes, mollusks, crustaceans, echinoderms, corals, seaweeds, and others. FishWorld is now recognized as a rescue and rehabilitation center for endangered marine animals. Recently, five marine turtles that have been in SEAFDEC/AQD's tanks for a month to a year were loaded onto a large outrigger boat and released in the Sulu Sea.

### **INSTITUTIONAL CAPACITY DEVELOPMENT FOR SUSTAINABLE AQUACULTURE**

Fishery resources provide food and livelihood to coastal communities and investment opportunities for the private sector. There is, thus, an urgent need for balanced development strategies that will ensure protection and sustainable utilization of the fishery resources. The Local Government Code of 1991 and Philippine Fisheries Code of 1998 provide that "The municipal/city government shall have jurisdiction over municipal waters which include streams, lakes and other inland bodies of water and tidal waters, fishery reserves and marine waters up to 15 km from the coastline." Effective and efficient governance of the fishery and aquaculture resources will depend on the capabilities and political will of the LGUs, the Fisheries and Aquatic Resources Management Councils (FARMCs), fisherfolk organizations, and other "on-the-ground" institutions.

In support of the government thrust to strengthen the capacities of local governments to manage and utilize their fishery resources for food and livelihood, SEAFDEC/AQD launched in September 2006 a project concept called "Institutional Capacity Development for Sustainable Aquaculture"



(ICDSA). The goal is to enable aquatic resource users to become efficient managers and prudent users of their resources by providing them with necessary knowledge and skills. The overall strategy is to transfer and disseminate science-based information and appropriate aquaculture and coastal resources management techniques. The approach is community-based, interdisciplinary and participatory: scientists and technologists, trainers and extension workers, LGU planners and development workers, members of people's organizations (fishers and farmers), NGO workers, and academe (faculty and students) consult and work with each other in the planning and implementation of projects and initiatives.

SEAFDEC/AQD's ICDSA team is interdisciplinary; it is composed of biologists, environmentalists, aquaculturists and socio-economists.

Two LGUs are now collaborating with SEAFDEC/AQD in the implementation of ICDSA projects. These are the provinces of Antique and Capiz on Panay Island in central Philippines. Local officials of the provinces of Ilocos Norte and Bulacan have also requested assistance from SEAFDEC/AQD to set up similar projects in their areas.

For the Antique project, the first activity of the SEAFDEC/AQD Team was to conduct a rapid appraisal of proposed aquaculture sites, then discussed with LGU officers the problems and issues affecting the fishery resources of the province. The team also conducted interviews with key informants, focus discussions, and general assembly consultations. As a result of the rapid appraisal exercises, a problem tree analysis (Figure 3) was built jointly by the team members in order to see the problems from the perspectives of the different disciplines (Callens and Seiffert, 2003). The Problem Tree was the team's initial output which became an input to the preparation of a working plan for the project (SEAFDEC, 2007). This Problem Tree will be revisited from time to time as changes occur due to interventions - such as training and information dissemination and aquaculture technology adoption - that are introduced by the project.

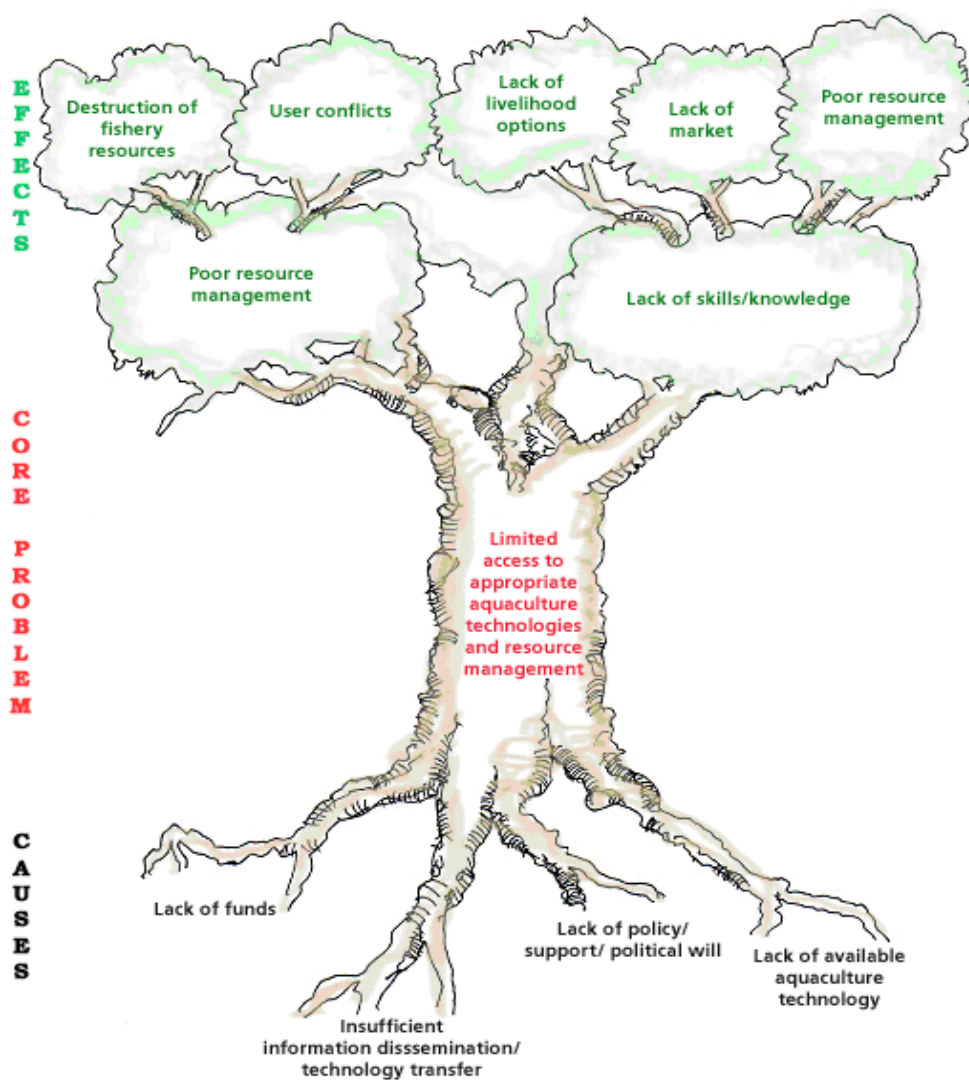

Figure 3. Problem Tree Analysis: Antique Province

The selection of aquaculture technology to be transferred to an ICDSA project site is demand-driven. The aquaculture sites should be suitable, and the technology appropriate for the intended users. Below is a list of aquaculture technologies that SEAFDEC/AQD has generated for hatchery and grow-out culture systems.

Brackishwater Aquaculture

1. Milkfish
2. High-value fish– Grouper, Seabass, Snapper, Siganids
3. Crustaceans – Shrimps, mudcrabs

Freshwater Aquaculture

1. Tilapia
2. Native catfish
3. Freshwater shrimps (Ulang)
4. Carp

Marine Aquaculture (seafarming, sea ranching, stock enhancement)

1. Seaweeds
2. Molluscs (Abalone)
3. Endangered species - angel wings, sea cucumber, sea urchin

Community-based Fishery Resources Management

1. Community organizing and empowering
2. Aquaculture livelihood
3. Aquatic Resource regeneration

The transfer of technologies for sustainable aquaculture (freshwater, brackishwater, and marine) in the project sites is anchored on the principles of sound fishery resources management, i.e. people-centered, environment-friendly and economically viable.

To complete the cycle of the R&D framework, there will be an assessment of the: 1) impacts of the adopted aquaculture technologies on the aquatic environment and on the socioeconomic condition of the technology users; and, 2) policy and institutional implications the adopted technologies on the overall management of the aquaculture environment. The information generated from the impact assessment will be used in the R&D planning of SEAFDEC/AQD.

It must be noted that SEAFDEC/AQD has had experiences in drawing up and implementing community fisheries resources management projects. Foremost of these is the community-based coastal resources management project on Malalison Island, Culasi, Antique (Agbayani, et al 2000; Baticados and Agbayani 2000). Implemented over an eight-year period (1991-98), the project was able to empower the Malalison fisherfolk to become active co-managers of their fishery resources. The project's capacity-building and social preparation activities included community organizing, leadership training, values inculcation; livelihood skills training (seaweeds and grouper farming), and environmental rehabilitation (construction and deployment of concrete artificial reefs). The data on marine resources generated by the SEAFDEC/AQD studies were used in the formulation of regulations that now govern the utilization and management of the coastal waters surrounding the Malalison Island. The Municipal Council of Culasi enacted ordinances that granted territorial use rights in fisheries (Siar et al 1991) to the Malalison fisher folk, and established a fish sanctuary that is now managed by the Fishermen's Association of Malalison Island.



## **BUSINESS PLANNING AND MANAGEMENT FOR SUSTAINABLE SMALL-SCALE RURAL AQUACULTURE VENTURE**

*Renato F. Agbayani*  
*Head, Training and Information Division,*  
*SEAFDEC/AQD, Tigbauan, Iloilo, Philippines*

### ***Note to Readers***

This material is for use in training courses in business planning and management for small-scale aquaculture ventures. It contains a format or content outline of a ***Business Plan for Sustainable Small-Scale Rural Aquaculture Venture*** that serves as guide for the preparation of a business plan. This deviates from the standard business plans and feasibility studies in that it deals not only with the usual concerns on technical, market and financial viabilities of a business enterprise but also with factors and issues relating to the sustainability of natural resources and social equity. True, profit and growth are still the primordial concerns of any business, but there has been a paradigm shift that goes beyond profit. The emerging business models now take into account in their planning and management strategies external concerns that, in the long run, will affect the bottom-line figures of their operations and the stability of the society in which they operate. These external concerns include: 1) participation in campaigns for the conservation and protection of natural resources, such as water, land, forest and coral reefs, for the equitable use of all stakeholders in this generation and the next; 2) extension of socioeconomic benefits to neighboring communities in order to foster smooth relationship; 3) participation in policy dialogues and development, especially those that affect their businesses; and, 4) extension of support to institutions and legitimate people's organizations that serve as catalyzers for positive change in society and as watchdogs against forces or elements that seek to destroy the fabric of society.

In order to enrich the learning experience of the aquaculturists and make them more aware of their responsibility and accountability in the exploitation of natural resources, this training material includes discussion of factual resource-sustainability and social issues. The author combined theoretical and empirical examples in the presentation and discussion of the various subject matters. The examples are simple and factual, based on selected publications and readings in aquaculture.

### ***Note to Trainers/Facilitators***

Trainers and facilitators must be well-grounded in all aspects of the aquaculture business, i.e. technical, market and marketing, and financial. It would be an advantage for trainers to keep abreast of global issues on sustainability of aquaculture as a business venture.

The Business Plan advocated by this paper is composed of 10 chapters. It is stated above that this Plan is different from the standard business plan or feasibility study; Chapters 1 and 2 show that difference. They lay out the industry systems and natural, socioeconomic and policy environments that the trainee-aquaculturists should consider in the preparation of their own business plans to ensure the sustainability of the business they are engaged in or intend to pursue. Chapters 3 to 10 are the standard content of the traditional business plan.

As shown in the examples provided by this Plan, the business plan that should be prepared by the trainee-aquaculturist should start with statement of objectives and an overview of topics in the succeeding paragraphs. Samples of how the trainees may write their own topic discussions in their business plans are given (in boxes or tables) for better comprehension and clarity. As learning enrichment, the author included under each chapter discussions of issues that are relevant to the chapter.

Chapter 1 is an introduction to the roles of the various sectors (production, support, and marketing) that comprise the aquaculture industry, and their interconnectedness that drives the flow and exchanges of goods and services, information and technology. The discussion provides a framework for the planning of a sustainable aquaculture venture. The schematic diagram should be reproduced either in a flip chart or a power-point format, if a computer will be used, to facilitate the discussion.

Together with Chapter 1, Chapter 2 gives an overall perspective of the complex natural, socioeconomic and policy environment in which aquaculture operates. The author discusses the issues that beset most, if not all, countries engaged in aquaculture.

Chapters 3 to 8 discuss the business operation and management. Chapter 3 (The Business) is a short and straight-forward discussion of the background and legal personality of the company that a trainee proposes to establish/rehabilitate/expand. For the benefit of the neophytes, it would be useful if the trainer/facilitator can give other examples of the type of business organizations that are used in local aquaculture ventures.

Chapter 4 (Market Study and Marketing System) describes the markets for fish, both domestic and export. The domestic market is usually the main market of small-scale aquaculturists. It may not be as lucrative as export, but it is constantly there. It is therefore important for the trainee-aquaculturists to know their domestic market. The small-scale aquaculturists, however, will eventually break into the export market, given the information and support on how to go global. It is important for them to know the intricacies of fish export so that they may be able factor these in their business strategies. For purposes of estimating demand for fish, a simple example is discussed to give the trainee an idea on how to project future demand for fish.

The trainer/facilitator may reproduce the diagram of the marketing system in a flip chart or power-point format to help the trainees understand the different aspects of marketing (usually referred to as the four “Ps” of Marketing) - product, place, price, and promotion. The arrows will lead the lecturer in discussing the topic.

The operation of a small-scale culture of tilapia in freshwater ponds in the Philippines is given as case study for Chapter 5 (Technical Study-Aquaculture Operations). Intended for readers who have no experience in aquaculture, e.g. financiers or investors, the case study presents in layman terms and simplified form the different aspects of fish farm operation. Pictures of fish farms (ponds or cages) will be useful in the discussion.

Chapter 6 (Enterprise Management Principles) presents general principles and management models that may be universally adopted, regardless of nature and scale of operations. The trainee-aquaculturists may choose which ones to adopt for their operation, bearing in mind the cultural milieu in which they operate.

Chapter 7 (Human Resources and Organization) discusses the various types of business organizations (single-family business, partnership, corporation, and cooperatives) that the trainee-aquaculturists may adopt for his business plan. An organogram of a fishery cooperative is shown so the trainees will easily comprehend the organizational structure.

Chapter 8 (Financial and Economic Analysis) is a combination of theoretical and empirical discussions of the accounting tools that businesses use to determine the profitability of their operations. The formulas have corresponding examples to facilitate learning. The examples (in Tables) –financial data of a crab farming operation - are simple and easy to understand. At the end of the chapter, the trainee can see the final outcomes of the exercises in terms of short-term profitability indicators. The tables should be reproduced in flip charts or power-point format.

Chapter 9 (Environmental Impact and Social Acceptability) discusses the impacts of the proposed aquaculture venture. Given as an example is a tilapia farming project for out-of-school youth in the Philippines. This chapter reiterates the sustainability issues discussed earlier in this training material.

Chapter 10 (Conclusion and Recommendation) gives samples of statements of decisions and actions to be taken as a result of a business plan.

The Executive Summary, although it precedes all chapters, should be prepared last. This part of the Business Plan should be a concise and straight-to-the-point write-up of the contents of the business plan. The Executive Summary provides a “snap-shot” of the aquaculture venture; it should be written in such a way that it arouses the interest of the intended readers, mainly investors, to read the entire document.

### AQUACULTURE INDUSTRY SYSTEMS: PLANNING FRAMEWORK

During the past four decades, aquaculture has become the fastest-growing industry of the food production sector of the world economy. The phenomenal growth of aquaculture can be attributed to a number of factors: the development of culture techniques in practically all the life stages of commercially important species of fish, mollusks, crustaceans and seaweeds; the formulation of affordable commercial feeds; the development of chemicals and drugs for health intervention; the support of governments and international fund donors for research and development, human resource development, and policy dialogue and development; the infusion of huge capital into high-risk profit aquaculture ventures; the development of communication technologies that facilitated the sharing of information; the development of transportation infrastructure that sped up the movement of goods; and the trade treaties of fish-producing countries and fish-importing countries that reduced or totally eliminated trading barriers.

Fig. 1 below illustrates the interconnection of the production systems, the marketing systems, the support systems, and the externalities of the aquaculture industry, in both the national and global scale.

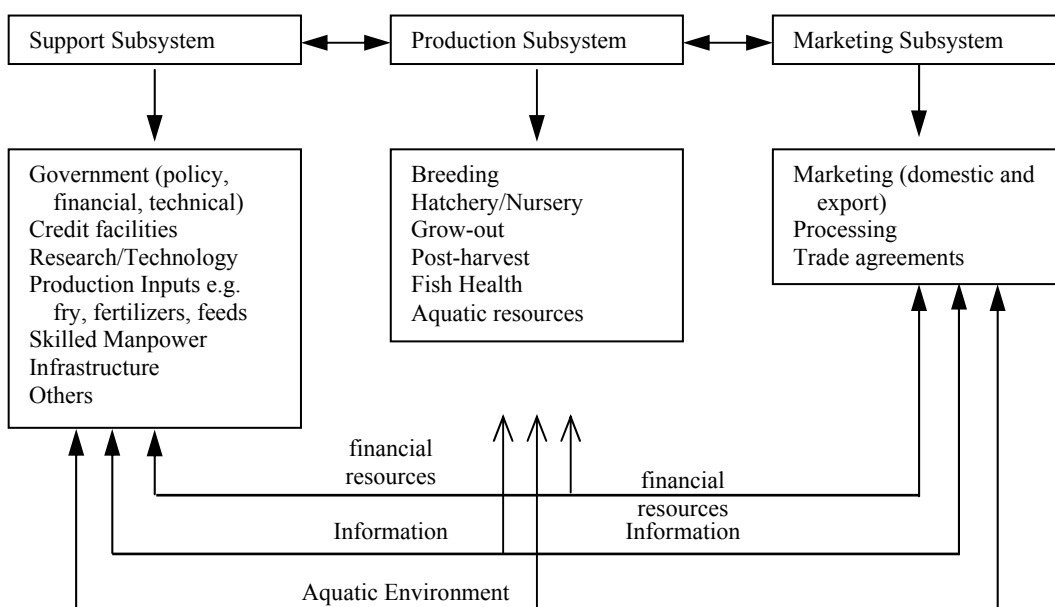

*Aquaculture Industry Systems*

## **Production system**

The core of the aquaculture industry is the production system. It is composed of: 1) breeding; 2) hatchery/nursery; 3) grow-out culture; 4) fish health; and 5) aquatic environment management. Technological breakthroughs in captive breeding, hatchery/nursery and grow-out culture of various species have opened opportunities for expansion and intensification of production in the various grow-out systems (pond and cage) in various water bodies, both fresh and marine waters. Intensive or high-density stocking systems have been developed in response to ever-increasing demand for fish, and to land-and-water use conflicts (use rights of competing stakeholders, environmental degradation).

Small-scale fish farmers, in southeast Asia, are still very much dependent on fry sourced from the wild. Worldwide, this seed source has been observed to be dwindling due to a number of factors such as overfishing, habitat degradation and increasing competition. The small-scale farmers, therefore, must have an alternative source of seed so that they can take advantage of grow-out technologies that allow high-density stocking and maximize the use of their ponds/pens during the seasons that are favorable for grow-out culture. They need to learn appropriate technologies in fish breeding, hatchery/nursery, farming and disease prevention and control that are technically and economically viable and environment-friendly. Given their remote location and low financial position, the small-scale fish farmers need the support of government and donor agencies in order to avail themselves of this alternative. They need assistance in sourcing capital and in accessing training programs and information channels.

The production system technologies require support from both the government and the private sector for them to be continually developed, improved and disseminated. Support is needed all the way from the education of researchers who conceive the technologies, to the experiments in laboratories and ponds, to the verification of the technical and financial viability of the technologies, and to their dissemination to target clientele.

At the R&D stage, support from the government and private fund donors is primarily in the form of funds for research, human resource development and institution building. Big business also extends help by providing funds for research and making their laboratories and facilities available for experiments and verification.

At the dispersal stage of mature technologies, big business usually gets benefited first because they have ready and easy access to current information, land and water resources, and funds for manpower development.

Because of their remote location and financial constraints, small-scale fish farmers do not have easy access to technologies and information generated by R&D. Thus, they need help from the government and concerned non-government organizations (NGO) to avail themselves of information and training in the application of such technologies. Assistance may be in the form of sponsored training, information dissemination campaigns, and soft loans to start or rehabilitate an aquaculture business. Private sector assistance may be in the form of soft loans from the banks, and credit facility for inputs from traders.

A vital help from the government is the formulation and efficient implementation of pro-poor policies, e.g. use rights of small-scale fish farmers to common property resources like rivers and municipal waters for them to manage and use for their livelihood operations; low-interest and non-collateralized loans from government banks to build facilities and buy equipment; low tariff for imported inputs, etc.

## **Market & marketing system**

The marketing systems and facilities (supply and market chains) are vital to the timely and safe delivery of inputs to the farm and of farm products to the intended markets. The supply and market chains significantly reduce or increase the profit of farmers, depending on their efficiency.

On the supply or input side, large-scale operators have a big advantage over the small-scale operators because they can buy their inputs at volume-discounted prices direct from manufacturers or distributors. They have storage facilities for inputs that they buy at big volumes when these are available at low prices (e.g. artemia for shrimp hatcheries). The small-scale operators, on the other hand, get their supplies from retailers at much higher prices, even predatory prices when bought on credit or during lean season.

In the marketing of produce, the big-scale operators get higher prices from export processors who pay premium for large volumes of say, shrimp, to optimize utilization of their facilities as well as to ensure meeting of their export orders. The big-scale operators also have direct access to big-volume buyers such as food processors and chains of supermarkets, fastfood outlets, hotels and restaurants. They have access to current information on prices and markets, and to communication media that facilitate communication with their customers. They also have transportation and storage facilities for timely and efficient delivery of their products to end-buyers.

The small-scale fish farmers, on the other hand, do not have the same marketing advantages. For market information, they rely mainly on middlemen who usually prey on their disadvantaged position and buy their products at low prices.

On the financing side, big operators have cash so they are not burdened with interest payments. Or if they need to take out a loan, they have access to low-interest loans from formal lenders like banks and government credit facilities. The small-scale fish farmers, on the other hand, do not have collaterals for loans so they rely on informal lenders who charge them usurious interest rates.

The pond/pen sites of small-scale fish farmers are often located in remote areas with bad roads and bridges. Cold storage and other post-harvest facilities are hard to come by in these remote areas. Oftentimes, the fish farmers' produce do not reach the market in fresh condition and so they are sold at low prices.

The government should, therefore, have a program to help the small-scale fish farmers in marketing their products. The government can initiate the forming of small-scale fish farmers' cooperatives that would, among other functions, facilitate the pooling of harvests to come up with big volumes that are normally desired by export processors, restaurant and hotel chains, fast food outlets and food manufacturers. The government can also help them by finding markets for their produce, training them in fish processing and value-adding techniques, building cold storage and post-harvest facilities in the remote areas.

Government investments in helping the small-scale operators would eventually redound to the national coffers in terms of taxes, and to a robust economy in the countryside.

## **NATURAL, SOCIOECONOMIC, AND POLICY ENVIRONMENT**

Aquaculture is the "sunshine" industry of the food production sector of most Asian countries, particularly China, Thailand, Vietnam, Indonesia, Malaysia, Taiwan and the Philippines. Cultured shrimp, finfishes and seaweeds are major exports of these countries to the US and Japan, the two biggest markets of fish and fish products. These exports bring in foreign exchange that helps keep afloat the economies of the fish-producing countries.



But the irresponsible aquaculture practices of the 1980s-90s also wrought damage to land and water resources – some irreversible – and spawned social problems in certain areas.

### **Impact on land and water resources**

In the 1980s-90s, vast areas of agricultural lands and mangroves were converted into aquaculture farms, mainly for intensive culture of shrimp and high-value finishes like seabass and grouper. These aquaculture farms were abandoned after only a few years of operation due to huge losses that resulted from shrimp and fish diseases and degraded environment. Most of these lands are now lying in waste, rendered unproductive by the salinity and silt left behind by aquaculture operations.

The clearing of mangrove forests to give way to aquaculture ponds/pens deprived shallow-water dwelling fishes, mollusks and crustaceans of their habitat, caused coastal erosion and siltation that adversely affected coral growth.

The excessive pumping of freshwater for aquaculture operation caused the subsidence of soil and, worse, the intrusion of saltwater into freshwater tables – an irreversible damage to a vital resource.

The chemical-laden effluents of aquaculture farms caused mass mortality of fish and other aquatic life in municipal waters and in the natural streams and rivers and man-made canals through which they were funneled out to sea.

### **Socioeconomic benefits; social problems**

#### ***Social and economic benefits***

Aquaculture has brought huge profits to large-scale fish farmers, export processors, traders of inputs, and middlemen; employment to many in the rural areas; taxes to the government; and foreign exchange to the economy. The enterprising small-scale fish farmers, especially those who formed cooperatives, have also benefited from the aquaculture boom. Some of them have even graduated into big-time operation. But many others have barely survived; quite a few went under.

Aquaculture has made fish available to all sectors of society: for the masses – tilapia, milkfish, mussels, grass carp, etc.; for the upscale market – shrimp, seabass, grouper, crabs, abalone, snakehead, etc. In countries afflicted with the “mad cow” disease and the avian flu, shrimp and fish fillet have taken the place of the blighted beef and poultry on the dining table of both the rich and poor. Aquaculture also supplies most of the protein needs of health-conscious societies – particularly in the USA, Japan and some Western European countries – whose culinary preferences have shifted from meat to fish for health reasons.

#### ***Social problems***

The poor coastal dwellers – particularly the small-scale fish farmers and fishers - have borne the brunt of the damage wrought by irresponsible aquaculture practices on nature. Their agricultural farm lots were rendered unproductive when these got flooded over by saline water and effluents of fish farms during rainy seasons. Their sources of water for drinking and household-use vanished when seawater intruded into freshwater tables as a result of excessive pumping of underground water. A rich source of their food and livelihood was destroyed and their homes were exposed to harsh winds and waves when mangrove forests were cleared for aquaculture. Their access to fishing grounds and transportation routes was impeded by ponds and pens that were built along the shores of rivers and municipal waters. Agricultural farmhands lost their livelihood when agricultural lands were converted into fish farms. Some farmhands who were able to re-invent themselves to become pond helpers were hired by aquaculture companies but there were more who ended up jobless because aquaculture operations need much less workforce than agriculture operations.

## **Programs, policies and laws for environmental damage control and social equity**

Governments in the Southeast Asian region responded to the natural and social problems spawned by aquaculture with pro-poor programs, policies and laws. With efficient prodding and guidance from research and academic institutions and “green” NGOs, the ASEAN governments came up with guidelines for granting environmental clearance for businesses to be able to obtain permit to operate, formed local and national councils that are tasked to conduct grassroots consultations on the co-management and equitable utilization of common property resources; declared as fish sanctuary areas that have been petitioned to become such after careful study; gave the villagers use-rights to municipal waters; sponsored training programs on skills development for the villagers’ alternative livelihood, and management training for community leaders. Some governments initiated the formation of cooperatives – of fisher folk or small-scale fish farmers – through which the governments channeled technical and financial assistance for livelihood projects such as seaweed farming, mollusk and finfish culture, and fish processing. The governments also built farm-to-market roads, and formed agencies that scoured the world for markets of their produce.

## **FAO Code of Conduct for Responsible Fisheries**

The FAO Code of Conduct for Responsible Fisheries sets out the principles and international standards of behavior for responsible practices to ensure the effective conservation, management and development of living aquatic resources. The Code recognizes the nutritional, economic, social, environmental and cultural importance of fisheries and the interests of those involved in the fishery sector.

## **International organizations and treaties that promote global fish trade**

The aquaculturists must adhere to a number of laws and regulations that deal with land tenure, water use, environmental protection, pollution prevention, public health and fisheries in general. A single model of aquaculture law cannot be formulated for the use of all countries because each country’s law should be framed within the context of their respective needs, resources, tradition and culture. These needs, resources, tradition and culture change over time; laws and policies are amended to address these changes.

Nevertheless, there is general agreement among countries that certain rules and regulations should be formulated and applied universally to ensure fair trade practices between and among the trading countries. They thus established regional and global organizations that would formulate such rules, oversee their implementation, and resolve disputes. Vietnam is a member of some such bodies: the World Trade Organization (WTO) and the Asia-Pacific Economic Cooperation (APEC).

The WTO administers trade agreements, holds forums for trade negotiations, rules on trade disputes, monitors national trade policies, provides technical assistance and training for developing countries, and fosters cooperation with other international organizations. WTO agreements cover goods, services and intellectual property. Member-countries are committed to lower, and eventually remove, tariffs and other trade barriers, and to open, and keep open, their markets and services to each other. WTO agreements also include preferential tariff and trade concessions for products from developing countries, and special arrangements with regional organizations such as the Association of Southeast Asian Nations (ASEAN).

APEC’s functions are similar to the WTO but its jurisdiction is over the countries in the Asia-Pacific region only.

**Note to trainee-aquaculturists**

*In preparing your own Business Plan, discuss the natural, socioeconomic and policy environments prevailing in your area of operation, as well as the national environment that you will have to contend with in doing your business.*

**THE BUSINESS**

**Box 1. Example of a history of an aquaculture enterprise**

The Fishermen’s Association of Malalison Island was organized in 1992 by small-scale fishers and farmers who were engaged or who planned to go into coastal resource management and small-scale aquaculture venture. The original membership was 200 fishers but this has decreased to just over a hundred because of poor production in their fish farms. The members were not able to acquire the required information and know-how in latest aquaculture techniques that would have improved their productivity.

The SEAFDEC Aquaculture Department provided technical assistance to FAMI through training and institution-building activities with focus on coastal resource management and small-scale aquaculture such as seaweeds farming. Annual workshops were conducted to evaluate the progress and impacts of the interventions of SEAFDEC and partner-organizations in improving the socioeconomic conditions of the fishers and the rehabilitation of critical fish habitats such as coral reefs and seagrass beds.

The bio-physical and socioeconomic impacts assessment showed positive indicators in terms of increase in biomass of fish and improved income of the fishers. Since then, FAMI pursued its community-based and cooperative efforts in managing the fishery resources and implement appropriate livelihood ventures including aquaculture.

**Box 2. Example of a description of a cooperative as an aquaculture enterprise**

The Fishermen’s Association of Malalison Island (FAMI) was organized by fishers and small-scale aquaculturists in the island of Malalison, Culasi, Antique as an instrument for attaining their common economic, social and cultural needs and aspirations.

The objectives of the cooperative are:

1. To engage in fishery resources management and small-scale aquaculture ventures either by family or as clusters of families;
2. To assist the members in dealing and transacting with the government and development organizations in acquiring technical, financial and marketing information; and
3. To strengthen their bargaining power in negotiating good prices for their products from traders and middlemen and lower prices of inputs from traders.

FAMI is managed by a Board of Directors (BOD) that formulates overall business policies. The Board is composed of five members: four who are elected by the cooperative members, plus the President as ex-officio member. The board members elect from among themselves the chairman and board secretary. The board members have a two-year term and they meet once a month.

The Cooperative’s day-to-day operation is managed by an executive group composed of the: 1) President; 2) Vice-President; 3) Business Manager; 4) Operations Manager; 5) Finance Manager; and 6) Marketing Manager. The officers are elected by the members of the cooperative and they have a two-year office tenure.



## MARKET STUDY AND MARKETING SYSTEMS

### **Note to trainee-aquaculturists**

*In preparing your business plan, describe the markets you cater to – domestic or export. Discuss the competition from other growers, the marketing systems (product development, channels of distribution, pricing and promotional efforts) needed to market your products effectively.*

### **General Market Description**

Box 3 is an example of a simple market description.

#### **Box 3. Example of a general market description**

The market for fish is large and continuously growing. As global population grows, as people become more health conscious, as culinary preparations of fish become more sophisticated and appealing to universal taste, and as animal and fowl diseases continue to threaten people's health, the markets for fish will continue to expand and grow.

In 2003, the Philippines was the 8<sup>th</sup> largest producer of fish, crustaceans, molluscs, and aquatic plants (seaweeds) with a total volume of 989,569 metric tons (FAO 2003). In 2005 the total aquaculture production of the Philippines was 1,895,847 metric tons with seaweeds comprising 70% and the rest were other species such as milkfish (15.25%), tilapia (8.6%), shrimps/prawns (2.11%) and others (3.44%). The domestic consumption of fish has been increasing with preference towards aquaculture products such as milkfish and tilapia because of stable prices.

Also in 2005, the breakdown of exports of fish and fishery products was: a: fish, crustaceans, mollusks and preparation (139,358 mt, US\$347,866,000), shells and by-products (7,854 mt, UA\$36,849,000), and miscellaneous and other fishery products (33,562 mt, US\$72,664,000). The total volume during that year was 180,774 mt valued at \$457,379,000. The major export market of fish and fishery products are Japan. USA. Taiwan, Korea, Germany, and Hongkong.

### **Demand estimates**

The size and the projected growth of the fish markets are important in determining the potential development of fisheries and aquaculture. The major factors that affect the demand of aquaculture products are population size and income.

The domestic market is important to the fishing industry, especially to the aquaculture sector. Institutional buyers such as restaurants, hotels, supermarkets and similar establishments are fast developing and have become major outlets for fish. High-value capture products, such as lobster, mackerel and squid, and aquaculture products, like shrimps and snappers, are in strong demand among institutional consumers. Household consumption of fish is increasing, especially fresh products.

In determining market trends or projecting demand for fish in a particular area or market segment, consumption data of the species are studied over time. However, it is very difficult to have these types of data unless the company is big and can spend some resources in gathering the data. As a general rule, estimating future demand is based on the average percentage increases during the past years. If the average increase is 3%, then demand projections will increase by 3% annually.

An example is shown in Box 4.

**Box 4. Estimate of demand for catfish**

Estimate of demand for catfish in Aklan Province based on past consumption:

<u>Year</u>	<u>Quantity (kg)</u>
2000	120000
2001	121230
2002	124700
2003	125690
2004	127790
2005	129900
2006	131900

Based on the above figures, the estimated yearly increase in the demand of catfish is 2% per year. Therefore, the projected demand for the next three years will be:

2007	135857
2008	139933
2009	144131

Future-demand projections are, at best, benchmark figures that will guide the fish farmer in his/her business plans. The fish farmer should always be aware of the changes in market trends and of the factors that affect the demand for fish products such as price, taste, nutritional value, and value-added features of the products.

**Marketing Plan**

A marketing plan presents the strategies of a business entity in satisfying the needs of its customers in order that its operations will profit and grow.

The marketing plan starts with objectives. Examples of marketing objectives are:

1. To sell 60% of farm products in Manila, 20% in Iloilo, and 20 in other parts of the country.
2. To penetrate the export market next year by selling quality fish to exporters and processors; and
- 3) To increase sales by 10% annually.

The marketing plan describes the four “Ps” in marketing goods and services, namely *product, place, price, and promotion*.

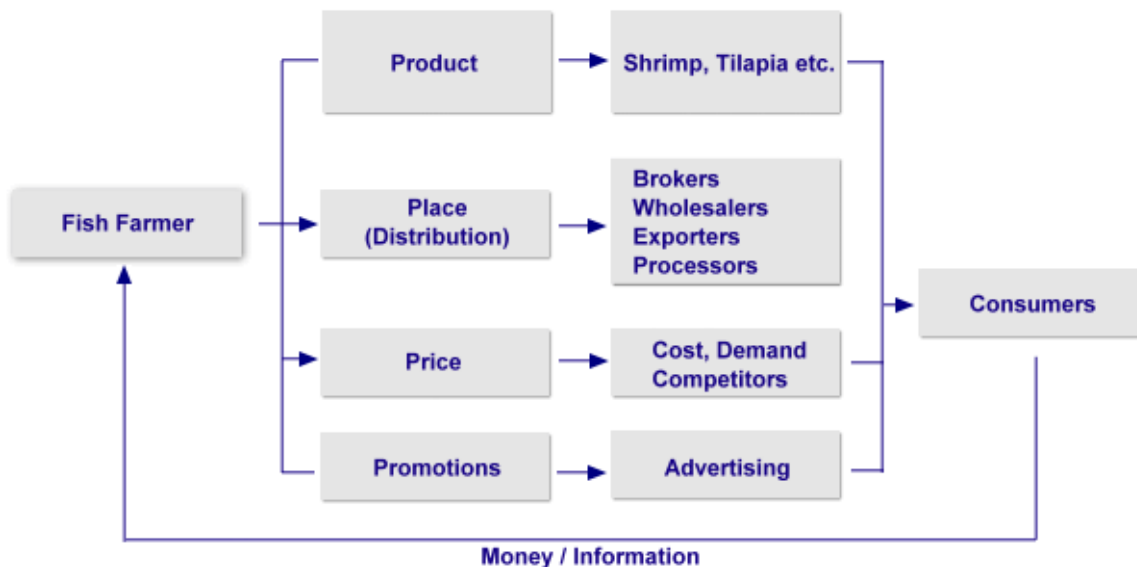

Marketing Systems

### 1. Products

Aquaculture products are mostly high-value species (shrimps, groupers, snappers, crabs, etc) with good export potential. However, species for domestic consumption, such as tilapia and snakehead, are popular products and fish growers have invested substantially to culture these species.

An aquaculture venture can specialize in one or two products, or engage in the polyculture of multiple species, depending on the company’s resources, technological capabilities, business management skills, and market coverage. An aquaculture venture may also engage in product development, such as fish processing and packaging in cans or bottles in order to prolong the shelf life of and add value to their fish products.

### 2. Place (Distribution channels)

In choosing a distribution outlet - whether a broker, wholesaler or exporter - profit optimization is a major consideration. The small-scale fish farmers do not always have this luxury of choice because of some constraints like lack of facilities to sell their products direct to consumers or fish processors. The small-scale fish farmers have limited influence over the distributors, unlike big aquaculture companies that can consistently supply good quality fish in large volume thus reducing the buying costs of processors or distributors. The small-scale fish farmers are at the mercy of big-time brokers and middlemen and they could not get good prices for their products.

Wholesalers play an important role in fish marketing and information dissemination. Majority of the fish products are sold to wholesalers who are classified into four categories: first, intermediate, last-stage, and multifunctional wholesalers. The fish, depending on the distance of the source to the market or processing plants, must pass several intermediaries before it reaches the end-consumers. Small farmers, because of their limited production, normally sell their products in nearby wet markets and local restaurants.

Processors play critical roles in distributing aquaculture products, especially in tapping distant markets such as export markets. The presence of fish processors in a certain area encourages more fish production because of the assurance of a reliable market for the producers. Value-adding of fish products, through processing and other product development activities, results to expansion of the demand for fish.

### 3. Pricing

There are three criteria in setting price schemes: cost of production, demand, and competition.

The cost criteria of the product include production and marketing costs, a reasonable allocation for fixed costs (depreciation and loan interest), and management and administrative overhead expenses. The aquaculture company will then put a reasonable mark-up as profit for his business.

An example is cost and pricing for shrimps per kilogram in Vietnam:

Cost of production -	VND 12,000
Marketing cost -	800
Total cost -	13,000
Mark-up (30%) -	3,900
Selling Price/kg -	16,900

However, the market forces (supply and demand) that dictate the prices in the market are competition from the produce of other farmers and from other fish products that give the consumers the same level of satisfaction.

If the market price for shrimp is VND 15,000/kg, which is lower than the computed selling price based on 30% mark-up, the fish farmers will have to decrease their price and make do with less profit. If competition becomes very tight and forces the market price to go as low as VND 13,000/kg, then the shrimp farmer is forced to sell at cost or break-even. This means no-profit, no-loss. There are times when the fish farmers are forced to sell at loss, when the market prices go lower than the fish farmer's production cost.

### 4. Promotion

The standard promotion and advertising strategies, using the popular media (TV, radio, print) are not employed by small-scale aquaculture companies. They rely on word-of-mouth to promote their products.

Big aquaculture companies that export their products do engage in advertising. Attractive product packaging is a form of advertising. Shrimp exported to rich western countries are contained in attractive packages in order to catch the attention of buyers in supermarkets and groceries.

## TECHNICAL STUDY (AQUACULTURE OPERATIONS)

### Project Site Facilities

This section gives the technical description of the proposed farm facilities. Farm facilities include ponds or cages, water systems, buildings, laboratories and instruments, and equipment like pumps, generators, blowers, etc. This section is important because it will be the basis for computing the cost of constructing the facilities and acquisition of instruments and equipment.

Box 5 is an example of a write-up on Project Site Facilities for a business plan.



#### **Box5. Project Site Facilities for Tilapia Culture**

**Tilapia Facility.** The pond facilities shall be constructed in a one-hectare pond located near the river. The ponds are for tilapia broodstock, nursery and grow-out culture. The specifications are:

Broodstock Pond: 2 units, 10 x 20 x 1.5m

Nursery Pond: 1 unit, x10 x 20 x 1.5m

18 units of hapa nets, 3 x 3 x 1.5m, inside the pond.

Grow-out Pond: 7 units, 10 x 20 x 1.5m

A deep well, made of concrete culverts, is the source of freshwater for breeders' conditioning and treatment, egg hatching, and larval rearing. Two units of 1/2hp water pumps are needed: one to pump water from the well direct to the ponds, and the other to pump water from the well into a 6-box re-circulating system.

The re-circulating reservoir measures 0.46 m wide, 2.5 m long, 0.77 m high; it is made of 2 cm-thick marine plywood.

An aeration system, consisting of a Roots blower and aeration pipeline (2 cm dia. PVC pipe) aerates the hatching troughs and multipurpose tanks. The four units of 1m x 1m x 1m multipurpose tanks - primarily used for broodstock conditioning or treatment - are made of 2 cm-thick marine plywood.

A concrete or wooden working table, measuring 0.61m x 2.5m x 0.76m, is located near the hatchery stockroom and sleeping quarters of the catfish hatchery technician and aide.

The sleeping quarters (3m x 5m) for the technician and aide, and stockroom (3m x 4m) are built near the four multi-purpose tanks.

**Dikes.** Soil excavated from the pond shall be used to construct the dikes. The specifications are:

Main Perimeter Dike: 2.0m base; 1.0m crown; 2.0m height

Secondary Dike: 1.5m base; 1.0m crown; 1.5m height

**Drain Gates.** Located at the northern rear of the tilapia facility, the specifications for the two concrete drain gates are:

Main Drain Gate: 0.7 m wide; 2.0m long; 2.0m high

Secondary Drain Gate: 0.5m wide; 1.5m long; 1.56m high

**Flume.** A flume, 46 cm wide and 61 cm high, is an open channel that is laid/buried on the crown of the central secondary dike from the reservoir pond to the grow-out ponds. The distribution gate from the flume to every pond is 15 cm wide with double grooves for slabs and screens. The inner side of the dike, where the water flows when the distribution gate is opened, should be rip-rapped to about 1 m wide.

#### **Production Process (Aquaculture Operations)**

The production process in aquaculture generally includes pond preparation, stocking, feeding, and monitoring, maintenance, and harvesting of fish stocks.

Box 6 shows the different activities in the grow-out culture of tilapia in ponds.



#### **Box 6. Grow-out culture of tilapia**

**Pond Preparation.** The protocol for the preparation of the grow-out pond is similar to those indicated in the preparation of broodstock and nursery ponds. Pond water is drained and replenished; unwanted species eradicated; pond soil is limed and fertilized; and, finally, flooded. The ponds are conditioned and prepared for the culture of natural food needed by the fish.

**Acclimation and Stocking.** Fry or fingerlings are acclimatized to a new environment by gradually equalizing the temperature of the transport water and the pond water to prevent the death of fish due to thermal shock after their release into the ponds. This is usually done by making the transport bags float on the pond water for at least 30 minutes before the fry are released from the transport bags into the pond water. The fish are stocked at 5/sq m or 50,000/ha.

**Feeds and Feeding.** Fish are given supplemental diets (25-30% protein) at 3-5% of their biomass. The daily feed ration is given equally during the 8:00AM and 4:00PM feeding schedules. The daily feed ration is adjusted every 15 days based on the stock sampling.

**Water Management.** The availability and maintenance of good water quality is the most important consideration in the culture of tilapia. Water depth is maintained at 80-150 cm. During the first 2 months of culture, water is drained and replenished to about 40-60% every two weeks. From the 3<sup>rd</sup> month until harvest, a flow-through water system is recommended due to higher biomass and feed inputs.

**Harvest and Post-Harvest Handling.** Harvest is done when a desired marketable size (100-200 g) is attained. Harvest can be partial or selective; only bigger ones are collected by cast net or seine net. This will allow further growth of smaller fish. Total harvesting can be done by totally draining the pond and removing all fish. Fish are placed in chilled water and packed in styrofoam boxes with 1:4 ice-to-fish ratio.

### **ENTERPRISE MANAGEMENT**

Enterprise management principles are learned from experience, and they have universal validity for almost all business situations. It is up to the managers to apply them intelligently to your project. Your aquaculture enterprise would be in a strong position if it is in the hands of a project manager who deeply believes in these principles and acts on them. These principles are:

- **Rule #1- Know your business.** Know as much as you can about your business, and more. Since you have decided to go into aquaculture business, make sure your business is financially and technically viable. Select the aquaculture systems that are good and appropriate for your site, resources, technical know-how, and market. Understand the value systems in your business and watch for changes. Be diligent, resilient, and resourceful. Learn and apply the best aquaculture practices. Define what is inside and outside your area of responsibility.
- **Rule #2 - Understand the customers' requirements and preferences.** Understand thoroughly and document the customers' needs and requirements. Requirements management is the leading success factor for good enterprise management, whether aquaculture, manufacturing or trading.
- **Rule #3 - Prepare a realistic and doable plan.** Prepare a plan that defines the scope, schedule, cost, and approach for a realistic and doable project. Make a schedule of activities within a time frame to ensure coherence and thoroughness, and to reduce waste of resources.
- **Rule #4 - Build a good team with clear definition of roles and turf.** Get good people and trust them. Give the members clear and well-defined tasks; ensure they have the tools and training needed to perform their tasks; and provide them with timely feedback. Emphasize open communication. Create an environment in which team dynamics can jell. Lead the team.

- **Rule #5 - Monitor project status and let others know.** Monitor the progress of operations. In aquaculture, good water management and feeding protocols and vigilance against diseases will spell the difference between good and bad production runs.
- **Rule #6 - Use Baseline Controls.** Budget and cost controls are examples of baseline controls. Establish baselines for the different fish species that are being cultured to determine if costs and budgets are within the projected figures. If changes are needed in the budget or in the cost of production, manage changes judiciously.
- **Rule #7 - Write down important matters, share it, and save it.** Document requirements, plans, procedures, and designs. Write down ideas and concepts and allow them to evolve and improve. Without documentation it is impossible to have baseline controls and reliable communications, or to repeat a process. Record all important agreements and decisions, along with supporting rationale and documents. They may be of vital use later.
- **Rule #8 - Ensure customer satisfaction.** Keep the customers' real needs and requirements continuously in view. Undetected changes in customer preferences, or not focusing the business on the customer's needs, are sure paths to project failure. Remember, a satisfied customer will always be a customer.

## HUMAN RESOURCES AND ORGANIZATION

For single-family proprietorship types, the owner is also the manager. S/He oversees all tasks: from pond preparation, stocking of fry, feeding, changing of water in the ponds, monitoring stock health and growth, to harvesting. If disease occurs, s/he will have to rely on his/her personal knowledge without benefit of technical advice from experts. S/He also takes care of selling the fish and collecting payments from buyers. Financial resources are limited to the family's financial assets. Family members compose the work force in the farm.

For business partnership, at least five investors agree to pool their resources to put up a business. They may manage the business themselves or hire professional managers, technicians and workers. Since there are more people involved, there are more sources of financing for the business operation. The partnership is disbanded once a partner decides to quit from the partnership.

A business corporation is created and governed by law. The business organizers, minimum of five, decide to put up a corporation. The company is registered with the appropriate government agencies following the corporation laws of the country. The corporation is financed through subscription of stocks or shares by investors. The value of the shares is based on the financial assets of the company. A corporation has a Board of Directors (BOD), with a minimum of five members who are chosen or elected by the stockholders. The Chairman of the Board is elected by the members. The President or Chief Executive Officer is usually a member of the BOD.

The organizational structure of a corporation is more complex than the other business organizations. Big aquaculture companies are normally organized as corporations. Corporations are attractive to long-term investors who, in turn, are preferred by big business set-ups. The liability of a corporation is limited to its assets.

Fishery cooperatives are institutions that are established by people involved in the fishery sector with common business aspirations. The members of a cooperative may be in fish capture, aquaculture, processing, or marketing. The main objectives of fishery cooperatives are focused on the development of the industry and well-being of the communities. They aim to increase income, improve standard of living and increase fish supply for their communities. Cooperatives started as grassroots organization. The members, usually from the poor sector of the workforce, e.g. workers, fishers and farmers, pool their limited resources and work together so they could get better selling prices for their products, lower buying prices for their production inputs, and have a united front in negotiating for credit or loans from lending institutions, both private and government.

In Japan, the fisheries cooperatives dominate 70% of the fish market. In Turkey, fisheries cooperatives are described as “insistent ideal” organization for fishers because they were born not out of the people’s desire for cooperation but out of the insistent and conscious organizational effort of the state bureaucracy.

A typical organization structure of a fisheries cooperative is shown below. There is a Board of Directors that is composed of five members. The board members are elected by the cooperative members. The chairman of the board is elected by the members of the board. The members invest in the cooperative by buying shares. These investments are part of the financial assets of the cooperative. If the cooperative earned profit, dividends are paid to members *pro rata*. Most governments are supportive of cooperatives. Government provides support to the cooperatives by sponsoring training and extension activities, extending low-interest financing, providing market information, and opening access to technology.

Below is a typical organizational structure of cooperatives:



Figure 3. Organizational structure of a cooperative

## FINANCIAL AND ECONOMIC ANALYSIS

This portion of the business plan is important to show to the creditors (banks and trade creditors) the financial viability of the aquaculture venture

### Simple cost and returns analysis

The cost and return analysis uses the undiscounted method of evaluating the economic feasibility of a business enterprise (aquaculture venture in our case) in the short term. Figures used in cost and returns computations are based on production and market information.

Tables 1-5 are examples of the computation of simple cost and returns analysis of tilapia culture in freshwater ponds.

Production and market data (Table 1) provides the basis for computing revenues of the tilapia farm.

**Table 1.** Technical Parameters of a Tilapia Grow-out Operations

1. Total area (m <sup>2</sup> )	1400
2. Stocking requirement (/m <sup>2</sup> )	30
3. Total stocking	42000
4. Duration of culture (mo)	4
5. Croppings/year	3
6. Survival rate	0.9
7. ABW (g)	150
8. FCR	1.2
9. Feed requirement/cropping	6804
10. Cost of feed/kg (PhP)	16
11. Production/crop	5670
12. Price of fish/kg (PhP)	50

### ***Investment requirements***

First step is to compute the investment requirements. There are two parts considered in estimating the amount of investment (Table 2). 1) capital outlay (cost of structures and equipment); and 2) working capital or operating capital (budget for cost of inputs e.g. fry, fingerlings, fertilizers, direct labor, fuel, electricity, supplies and materials, etc). The sum of the capital outlay and the working (operating) capital is the total investment requirement. The business organizers put up the required capitalization from their own individual resources. If their fund is insufficient, the company may borrow from either formal (banks) or informal lenders. The loan bears interest and is payable at an agreed duration.

**Table 2.** Investment Requirements for Tilapia Grow-out Operations

						Amount
A. Capital outlay						
1. Pond excavation and diking (1400 m <sup>2</sup> x 0.5 m) =				700	80	56000
2. Reservoir						
a. Excavation & diking P18000/2						9000
b. Cement plarform P600/2						300
c. Hollow block division P5600/2						2800
d. PVC pipe 6" dia. 46 pcs @1154 = P49622/2						26542
e. PVC coupling 6" dia 42 pcs @P450=P18000/2						9000
f. PVC ball valve 6" @P650/2						325
3. Gates						
a. Concrete drain gate P10000 + reservoir drain gate P5000 + slabs & screens P3500						18900
b. Concrete sec. Drain gate 7 units @P6000 and P5000 slabs and screens						42000
4. Flume						
50 m X 200/2 + slabs & labor P1500						5000
5. Harvesting shade/stock room P13,000/2						6500
6. Caretakers hut P13000/2						6500
	Subtotal					182867
B. Working capital (one run)						160,053
C. Total Investment						342920
Sources of Funds					Interest	
Equity		10.00%		34292		
Loan	18.00%	70.00%		240044	43208	
Grant		20.00%		68584		

***Production cost***

Computing the production cost is important in order to monitor the cost effectiveness of the aquaculture venture. The total cost is composed of two parts: 1) variable or operating cost; and 2) fixed cost. Variable costs are the cost of inputs (fry, fingerling, feeds, chemicals, direct labor, etc.). Variable costs change, depending on the level of operation. Fixed costs are the depreciation of capital assets, interest expenses and salaries of fixed term employees (management and administrative) that do not change over a long time.

***Variable cost***

Variable costs are the cost of direct inputs, e.g. fry, fingerlings, fertilizers, direct labor, etc. The variable cost of each item is computed by multiplying the quantity (pieces, kilograms, etc) by the unit cost of the item. Refer to Table 3, item *B. Variable Costs*.

**Table 3.** Cost and returns - Tilapia Grow-out Operations (Philippine Peso)

				Per run	Per year
			Unit		
Revenues		Quantity	Price	Total	Total
Sale of tilapia		5,670	50	283,500	850,500
Less:					
Variable cost					
Cost of fingerlings		42,000	0.24	10,076	30,227
Feeding		6804	16	108,864	326,592
Electricity				0	0
Lime		196	1.3	255	764
Manure		196	1.2	235	706
16-20-0		7	8.5	60	179
45-0-0		3.5	8.5	30	89
Labor					
Technician (P5000/mo)		0.25	30000	7,500	22,500
Aide (P3500/mo)		0.5	21000	10,500	31,500
Casual (5 person-days)		4	115	460	1,380
Food allowance for technicians		3	25	2,250	6,750
Honorarium for Manager		0.25	5000	1,250	3,750
Marketing expenses (2% of sales)				5,670	17,010
Repairs and Maintenance (5% of capital assets)				10,904	32,713
Miscellaneous expenses				2,000	6,000
	Subtotal			160,053	480,160
Fixed cost					
Interest expense				14,682	44,045
Depreciation				7,512	22,535
Management and Administrative overhead (P5000/4/mo)				5,000	15,000
Land lease - P15,000/yr for 1st 2 years				1,250	3,750
	Subtotal			28,443	85,330
Total Cost				188,497	565,490
Income before tax per run				95,003	
Annual income (3 runs)					285,010
Return on Investment (ROI)					83.11%
Payback period					1.12
Cost of tilapia/kg					33.24

### **Fixed cost**

Fixed costs do not change regardless of the level of production. It means that even if the aquaculture farm is not operating, the business incurs fixed costs nonetheless. Examples of fixed cost are depreciation of capital assets and interest of borrowed money.

*a. Depreciation cost.* Depreciation is the allocation of the cost of a capital asset (building, equipment) over its economic life of more than a year. The straight-line method is the most common method of computing depreciation cost. The formula is:

$$\text{Annual depreciation} = \frac{\text{Original cost} - \text{salvage value}}{\text{Economic life}}$$

The salvage value is the estimated “left over” or residual value of a capital asset at the end of its economic life.

**Table 4.** Depreciation cost (Philippine Peso)

	Amount	Econ. life	Salvage value	Depr
<b>A. Capital outlay</b>				
1. Pond excavation and diking (1400 m2 x 0.5 m) =	56000	10	0	5600
2. Reservoir				
a. Excavation & diking P18000/2	9000	10	0	900
b. Cement platform P600/2	300	10	0	30
c. Hollow block division P5600/2	2800	10	0	280
d. PVC pipe 6" dia. 46 pcs @1154 = P49622/2	26542	5	1327.1	5043
e. PVC coupling 6" dia 42 pcs @P450=P18000/2	9000	5	450	1710
f. PVC ball valve 6" @P650/2	325	5	16.25	62
3. Gates				
a. Concrete drain gate P10000 + reservoir drain gate P5000 + slabs & screens P3500	18900	10	0	1890
b. Concrete sec. Drain gate 7 units @P6000 and P5000 slabs and screens	42000	10	0	4200
4. Flume				
50 m X 200/2 + slabs & labor P1500	5000	5	0	1000
5. Harvesting shade/stock room P13,000/2	6500	10	0	650
6. Caretakers hut P13000/2	6500	5	650	1170
	Subtotal			22535

*b. Interest expense.* Interest paid for borrowed money is a fixed cost. It is simply computed by multiplying the interest rate by the amount of the loan. In Table 2, the amount of loan of the tilapia farm is PhP 240,044, bearing 18% annual interest. Thus, the interest expense of our example is PhP 43,208.

### **Total cost**

The total cost is the sum of the variable cost and the fixed cost. The cost per unit (kg) is computed by dividing the total cost over the quantity of fish produced.

In our example, the cost of producing one kilogram of tilapia is:

$$\frac{\text{PhP}188497}{5,670 \text{ kgs}} = \text{PhP } 33.24$$

### **Profitability indicators**

In determining short-term profitability, the following indicators are used:

1. Net profit (Income) = total revenue – total cost of production  
= PhP 850,500 – 565,490  
= PhP 285,010
2. Return on investment (ROI) = Net income/total investment  
= PhP 285,010/342,920  
= 83.11%
3. Payback period (PP) = total investment/(net income + depreciation)  
= 342,920/ (285,010+22,535)  
= 1.12 years

The profitability indicators show that the tilapia farming is financially viable. For every PhP 1000 invested in the business, PhP 831.10 is earned in one year. The payback period is 1.12 years. This means that the original investment is recovered in a little over a year of operation.

There is no hard-and-fast rule regarding minimum figures to indicate acceptable profitability levels. So much will depend on the prevailing investment opportunities in a certain place and time. There might be competing investment opportunities but with different risk levels.

The simple cost and returns analysis will provide the investors a picture of the relationships between the cost, revenues, and the profitability of their investment.

### Simple accounting and bookkeeping records

In addition to the previous examples on cost and returns, simple accounting records and bookkeeping practices are useful in aquaculture operations and management (Tables 6-10). Fish farming activities include pond preparations, fertilization, purchase of fry and juveniles, feeding, farm maintenance, harvesting, and marketing. For small enterprises, simple accounting records will help the farmer monitor the flow of expenses and the status of the cost of production and revenue of the business.

A daily record of operating expenses will help the fish farmer monitor the cost of production (Table 6).

**Table 6.** Sample of a daily record of operating expenses

Date	Pond/cage No.	Item	Kind	Quantity	Unit cost	Total cost
1-May	1	Fry	Shrimp	10000	2	20000
3-May	2	Feeds	Pellets	10	10	100
5-May	3	Gasoline	Diesel	10	3	30
30-May	2	Chemicals		3	20	60
Total						20190

Labor costs are incurred in all the activities, whether the laborers are members of the family or hired labor (Table 7).

**Table 7.** Daily Record on labor cost

Date	Pond /cage	Activity	Kind of labor	Number of laborers	Number of days	Daily rate	Total Labor Cost
1-Jul	1	Pond preparation	Daily	5	5	80	2000
15-Jul	2	Repairs of cage/pond	Daily	2	6	100	1200
30-Jul	3	Harvest	Daily	6	1	80	480
Total							3680

Recording of sales (Table 8) will make it easy for the fish farmer to prepare a cost and returns computation at the end of a business period, whether per crop or per year. The record can also show the source of fish, whether in pond 1 or cage 3, so that inventory of the fish stocks in the different compartments (ponds or cages) is regularly monitored and controlled.



**Table 8.** Sales Record

Date	Pond/cage	Species	Quantity (kg)	Unit Price	Revenue
June 1	1	Tilapia	1200	50	60000
June 15	2	Shrimp	500	200	100000
June 30	3	Snapper	800	50	40000
Total					200000

Efficient management of assets is important because of the high cost of acquisition. The inventory of assets will serve as guide in the maintenance of these assets in order to prolong their usefulness.

**Table 9.** Inventory of assets and estimated economic life

Type	Acquisition/Construction Cost	Date of Purchase	Economic life
Building	30,000	Feb-04	10
Transport	20,000	Mar-05	5
Nets	15,000	Apr-06	3
Equipment			
- Water pump	10,000	Apr-06	5
- Generator	20,000	May-06	5
- Blower	10,000	Jun-06	5
- Feed mixer	5,000	Jul-06	5
- Refrigerator	5,000	Aug-06	10
- Others	1,000	Sep-06	5
Total	216,000		

Good financial management requires prompt payment of loan (principal and interest). Keeping records of loan (Table 10) is, therefore, imperative in the overall management of the business.

**Table 10.** Record of loans

Date borrowed	July 6, 2006
Amount borrowed	VND 30,000,000
Source of loan	Vietnam Farmer's Bank
Purpose of loan	Purchase of equipment, pond repairs
Terms of loan	
Length (years)	5
Annual Interest	6%

## Payment of the loan

Date	Outstanding	Interest paid	Repayment of principal	Total payment
July 6	VND30,000,000			
Oct. 6		450,000	1,500,000	1,950,000
Oct. 18	28,050,000			



## ENVIRONMENTAL IMPACT AND SOCIAL ACCEPTABILITY

Below is an example of the discussion on the environmental and social acceptability of an aquaculture venture. This is the case of the tilapia culture project for out-of-school youth in Aklan, Central Philippines.

### **Box 7. Environmental impact and social acceptability of a tilapia culture project**

#### **A. Environmental impact**

*Preservation and protection of trees in the project site.* The trees growing on the project site - mangrove, gemelina, mahogany and eucalyptus - will not be cut.

*Revival of native catfish in freshwater bodies.* The native catfish is an endangered species that nearly disappeared from the country's freshwater bodies because it was preyed upon by the imported African and Thai catfish. The Jawili project will open the way to the revival of the native catfish in the freshwaters of Tangalan and neighboring areas.

*Productive use of Jawili Falls water.* The proposed project will make good use of the free-flowing water of the Jawili Falls instead of just being wasted away.

*Clean-up of waterfalls pollutants.* The Jawili project will need clean water. The project will thus spur the municipal and barangay governments, which are both supportive of the project, to come up with measures to eliminate such pollutants as shampoo and soap suds of bathers in the waterfall basin, and to regulate the disposal of picnicker's trash.

*Disciplinary measures for waterfalls polluters.* The representatives of the different sectoral organizations in Jawili concurred with the village Council's move to draw up measures, including punitive sanctions, for the elimination of pollutants in the Jawili Falls water and of trash in surrounding areas.

#### **B. Social Acceptability**

The social concerns of the project were:

*No social displacement.* The proposed project is an idle site and unoccupied land. Nobody loses abode or job when the project is established on the lot.

Out-of-school youth will be trained in best practices of pond aquaculture. The skills will enable them to be employed in the project and make them productive members of the community.

*Women's role in the Project.* There is no position in the project that discriminates against women. All the positions – from manager to aide – may be occupied by healthy women who have the requisite academic preparation, skills, aptitude, and attitude.

There are certain work in the operation that require physical strength, such as carrying of water-filled pails, scraping pond bottoms, starting generator, and repairing of dikes, but women who are healthy and are willing to take on the jobs will have equal crack at the jobs as men.

*Hiring of residents.* The residents were assured that they will be given first priority in the hiring of workers, provided they are qualified, during the development phase of the project.

*Environmental safeguards.* The residents were assured that the production processes are environment-friendly. Environmental management measures to neutralize or pre-empt the adverse impact of some production activities were explained to them.

## **CONCLUSIONS AND RECOMMENDATIONS**

The proponents of the aquaculture project should be able to make sensible conclusion and powerful recommendations to convince investors and banks of the worthiness of the proposed business.

### **Box 8. Examples of statements of conclusions and recommendations**

1. The proposed crab culture project is economically and technically feasible.
2. The project will provide the small-scale fish farmers additional income and source of food.
3. The proposed project is socially acceptable because it will generate employment and livelihood opportunities for the community and provide them access to market and technological information.

In view of the above conclusions, the following are the recommendations:

1. To organize a fishery cooperative among the small-scale fishers of Thua Tien Hue province.
2. To train the members of the cooperative in best aquaculture practices and enterprise management.
3. To negotiate with a government financing institution to provide the cooperative low-cost financing packages.



## CHAPTER 5

### SUGGESTED READING

#### **Community-Based Aquaculture in India – Strength, Weakness, Opportunity and Threats**

*Radheyshyam*

*Senior Scientist of Central Institute of Freshwater Aquaculture,  
Kausalyaganga, Bhubaneswar- 751002, India.*

#### **Abstract**

Community-based aquaculture founded on the principles of common interest groups working together regardless of sex and age has been an effective tool for implementing scientific aquaculture programs in India. Water bodies that do not interest villagers are targeted for use to avoid communal problems. Farmers who share common interests are identified and organized and a team leader chosen among them. An inventory of resources using the SWOT analysis is made. A participatory approach to identify major problems, socioeconomic and biophysical constraints is used and appropriate interventions are planned. This process is then evaluated and the results of the impact assessment are provided to research/extension/policy planners for setting directions and priorities for further improvement. The potential for expanding community aquaculture for generating self-employment and improving food security of the rural poor as well as improving the environmental conditions of the villages in India can be further tapped.

#### **INTRODUCTION**

About 80% of India's population lives in villages and 90% of its rural population depend on agriculture and allied activities for their livelihood. During the last few decades, a number of programs have been implemented in rural India for the socioeconomic upliftment of the population. However despite these efforts, the objectives of socioeconomic development, employment generation and improvement of food security have not been achieved. Various quarters now feel that the single important reason for this failure has been the lack of organizational capacity among the poor. Poverty in general and ignorance in particular stand as two main barriers in the development of such capacities even on a cooperative basis. In many cases, the aid provided to individuals for implementation of development programs gets diverted to consumption subsidies. As a result, they not only remain resource deficient but are also unable to derive benefits from public investments. Given these conditions, the concept of community-based aquaculture can be an effective and ideal tool for implementing scientific aquaculture programs by organizing common interest groups in an informal way, utilizing semi-derelict and swampy water bodies and community village ponds. This paper describes how community-based aquaculture is being carried out in India.

#### **PRINCIPLE OF COMMUNITY-BASED AQUACULTURE**

In community-based aquaculture, common interest groups work together by sharing equal responsibilities irrespective of sex and age. Such working groups are essential for aquaculture operations, which involve construction of new or renovation of old ponds, eradication of aquatic weeds and management of culture operations which include fertilization of ponds, feeding fish, monitoring growth, security, harvesting and marketing, etc. As community aquaculture is informal there is little paper work to manage.

## **RESOURCE POTENTIAL FOR COMMUNITY-BASED AQUACULTURE**

Natural resources are the ecological boon for economic development of rural communities. Various water resources – large, medium and small water-bodies are available for community fish culture in villages, but most of them are underutilized and/or unutilized. Some unconventional water areas such as canals or roadside ditches have the potential for intensive aquaculture. The village sewage which drains into burrowed pits emit foul smell and provide breeding grounds for mosquitoes. Such water-bodies can also be exploited for community-based fish culture.

## **METHODOLOGY LOCATION AND RESOURCE INVENTORY**

To begin with, an area is surveyed for its resources and socioeconomic characteristics so as to evaluate its potential for community-based aquaculture. As far as possible, water bodies with community interest or involving interests of different groups in the same village are avoided as this may lead to communal problems amongst the villagers. Instead derelict water bodies, swampy areas, burrowed pits and ditches by roadside, railway tracts and irrigation canals, etc. which normally do not interest the villagers are targeted for use. Identification of common interest groups and organizing them at the initial stage is a difficult task for the implementing and aid agencies.

Farmers who share a common interest are identified and organized, and from these a team leader with appropriate leadership qualities is chosen. The team leader must be a farmer, sociable, influential, responsible and have missionary zeal for serving his fellow farmers/rural poor. He should be easily approachable and flexible enough to work along with fellow fish culturists. Depending upon the agro-climatic conditions and resource availability, the potential exists for carp breeding, carp seed rearing, composite fish culture and integrated fish farming by the communities. Before implementation, an inventory of resources is made using the participatory approach.

## **SWOT ANALYSIS**

SWOT analysis is an informative tool for assessing the potential of aqua-farming. It provides a complete picture of its potential strengths (S), weaknesses (W), opportunities (O), and threats (T). It helps in problem identification, planning, decision making, appropriate technology implementation, precautionary measures for accelerating fish production at sustainable level, etc. A SWOT analysis carried out with the participation of farmers in a community is summarized below:

### **Strengths**

- Availability of diversified natural and man-made water resources in rural areas with potential for higher productivity, cost reduction/saving, multiple cropping/harvesting, risk reduction and reduced rate of degradation.
- Continuous accumulation of allochthonous organic matter from the village catchment area and from domestic drainage enriches water resources with nutrients for cost effective fish production.
- Availability of under utilized and/or unutilized human resources, agricultural and livestock wastes and cheaper fish feed ingredients.
- Availability of region- and resource-specific technologies.
- Involvement of common interest groups with equal and joint responsibility lends strength to and facilitates better operation of aquaculture.

### **Weaknesses**

- Poor organizational capacity among rural farmers due to preexisting personal disputes and lack of capable community leaders.
- Rural farmers lack infrastructure, ponds, material inputs, credit facilities, etc. for carrying out fish culture.

- Farmers are reluctant to participate in such schemes because of inequity in multi-ownership of the community ponds.
- Weak research-extension linkages, poor cooperation among operational agencies, low technical awareness among the community members, and a lack of commitment and understanding from farmers, etc.
- Dual leasing policy, short leasing period, increased leasing rates, multi-water rights for irrigation, bathing, drinking and other domestic purposes of the community ponds.
- Vandalism among the fisher folk and social stigma, poor training facilities at grassroots level, ambivalence towards the involvement of women in fish culture and poor marketing facilities in the region.

### **Opportunities**

- Increased aquatic productivity and contribution to economic efficiency, social equity and environmental sustainability.
- There will be equity in income, employment, food security, and poverty reduction, as well as participation and empowerment of rural farmers and rural women.
- Judicious utilization of available nutrient-rich village water resources, human resources and waste materials for multi-commodity production at one place.
- Easy implementation of carp seed production and rearing, composite fish culture, integrated fish farming, cage/pen fish culture, value addition and processing and marketing technologies through community approach.
- Landless and resource poor farmers have the opportunity to undertake fish culture in leased out ponds.
- Rural poor get equal chance in decision making, planning, implementation, harvesting and marketing, monitoring and evaluation, profit distribution and feedback.
- There is participatory learning by fish farmers irrespective of sex and age, and empowerment of the rural poor.
- Reduction in migration of fisherfolk to other parts of the country as wageworkers.

### **Threats**

- If aquaculture is not undertaken in unutilized and/or under utilized village water bodies, they will be infested with aquatic weeds providing breeding grounds for mosquitoes and may cause health hazards for the villagers.
- Entry of polluted water from agricultural surface-runoff, domestic drainage and industrial effluents is not only a major threat to the survival of aquatic organisms but also contributes to water deterioration and affects the sediment quality of community ponds.
- Introduction of indiscriminate fishing and illegal species.
- Weed infestation, poor water quality and disease outbreak in fish.
- Natural disasters such as floods, cyclones and droughts.
- Declining per capita fish catch and irregular income generation.
- Unemployment, food insecurity and labour migration in search of a means of livelihood.
- Reluctance to invest due to short leasing policy.
- Social conflict due to increased incomes from technology implementation.

## **PROBLEM IDENTIFICATION FOR TECHNOLOGY IMPLEMENTATION**

For better implementation, it is necessary to prepare location maps, Venn-diagrams, transect maps, hydrological maps, system maps, time lines and crop calendars of the target villages for reference by involving the community. A participatory approach is used to identify major problems, socioeconomic and biophysical constraints and plan appropriate intervention points. Constraints are prioritized and ranked according to criteria such as extent, severity, importance and frequency (Table 1). Appropriate technologies are then identified. Since at any single intervention point the technological integration may not produce the desired improvement in productivity, many intervention points (constraints) are considered for technological integration at a time alternatively and/ or simultaneously.

## IMPACT ASSESSMENT

At the end of each technological implementation (on farm trials, farm research and demonstrations), the performances are evaluated based on indicators such as technical observations, economic profitability, farmer's reactions, etc. The fish farmers' reactions to technological flexibility and divisibility, ease of handling, compatibility with household resources and existing farming system, easy availability of input materials, element of risks and alternative suggestions from the farmers for refinement are recorded. After the evaluation and impact assessment of technology implementation, feedback is provided to the research/extension/ policy planners.

Impact assessment of community based aquaculture is carried out in three stages viz. i) *ex ante* impact assessment and priority setting; ii) monitoring and evaluation; and iii) *ex post* impact assessment. The *ex ante* impact assessment and priority setting uses an innovative approach in application and management of community-based fish culture through subjective and qualitative assessment of expert-opinion and user's demand potential backed up by benchmark information (production and demand). The outcome of the community-based aquaculture management model application is monitored and evaluated based on users experiences, institutional analysis, socioeconomic and environmental cost-benefit analysis, etc. Finally, the *ex post* assessment is carried out upon implementation of the appropriate technological packages including assessment of adoption, lags and gaps analysis, comparison between potential and realized outputs, input costs and returns, environmental assessment, etc. This will generate information for scientists and research/extension managers for setting directions and priorities and allocating resources for further improvement.

## CONCLUSION

In rural India, major water resources are owned by village communities and the revenue department. The water resources are neither leased to farmers nor utilized by the concerned department because of social and political reasons. The majority of farmers in rural areas do not own ponds and over 67% of freshwater fish farming in certain areas of the country is undertaken in leased out ponds. Due to the short leasing policy, farmers are reluctant to make investments, resulting in ponds remaining under utilized and/or unutilized for fish production. By leasing such ponds on a long-term basis to common interest group farmers of the village, fish productivity can be enhanced many fold. This would provide self-employment to the rural poor in their villages.

In community aquaculture management, social, cultural, economic, political and environmental conditions of the community members are considered for sustainable, profitable, stable, equitable and compatible development of rural aquaculture. At the same time, judicious exploitation of human and water resources, village infrastructure and waste materials is carried out with proper coordination by operational agencies and strong cooperation from fellow farmers of the community. In community aquaculture, decision making, planning, technology implementation, control and maintenance management measures and evaluation of activities are carried out with the participation of members of the community. There is rational exploitation of resources, equitable

profit distribution, conflict resolution and compliance with agreed terms and conditions. It would not only provide income, self-employment and food (fish) security to the rural poor but also improve environmental conditions of the villages. There is ample scope for the development of community aquaculture for generating self-employment and income and improving food security of the rural poor. Its potential for expansion in the country with regard to agrarian economy in general and aquacultural economy in particular, is high.



Problems	Criteria					
	Extent	Severity	Importance	Frequency	Score	Rank
Lack of knowledge	*****	*****	*****	*****	20	Ia
Lack of own ponds	*****	*****	*****	*****	20	Ib
Inadequate quality fish feed	*****	****	*****	*****	19	III
Inadequate manure and fertilizer	****	****	*****	*****	18	IVa
Aquatic weed infestation	****	*****	*****	****	18	IVb
Poor management of soil and water	****	****	*****	****	17	V
Multi-water rights	*****	***	***	****	16	VIa
Poor pond management	****	****	****	****	16	VIb
Presence of predatory and weed fishes	***	****	****	****	15	VII
Most ponds belong to village administration	****	****	***	***	14	VIIIa
Inadequate quality fingerlings	***	***	****	****	14	VIIIb
Short duration lease	***	***	****	***	13	IX
Natural disasters	***	***	***	***	12	X
Seasonality of ponds	***	***	**	***	11	XI
Non-availability of suitable piscicides	**	**	***	**	9	XII
Lack of money	**	*	***	**	8	XIII
Disease outbreak	**	*	**	**	7	XIV
Poaching	**	*	**	*	6	XV